



Professional Radio GM Series

Detailed Service Manual

6864115B62-A

Professional Radio

GM Series

Detailed Service Manual

68P64115B62-A

Contents

Section 1	Service Maintainability
Section 2	Controlhead Service Information
Section 3	Controller Service Information
Section 4	VHF Service Information
Section 5	UHF Service Information
Section 6	LowBand Service Information



Professional Radio GM Series

Service Maintainability

Issue: March 2001

Computer Software Copyrights

The Motorola products described in this manual may include copyrighted Motorola computer programs stored in semiconductor memories or other media. Laws in the United States and other countries preserve for Motorola certain exclusive rights for copyrighted computer programs, including the exclusive right to copy or reproduce in any form, the copyrighted computer program. Accordingly, any copyrighted Motorola computer programs contained in the Motorola products described in this manual may not be copied or reproduced in any manner without the express written permission of Motorola. Furthermore, the purchase of Motorola products shall not be deemed to grant, either directly or by implication, estoppel or otherwise, any license under the copyrights, patents or patent applications of Motorola, except for the normal non-exclusive royalty-free license to use that arises by operation of law in the sale of a product.

Table of Contents

Chapter 1 INTRODUCTION

1.0	Scope of Manual	1-1
2.0	Warranty and Service Support.....	1-1
2.1	Warranty Period and Return Instructions	1-1
2.2	After Warranty Period.....	1-1
2.3	European Radio Support Centre (ERSC).....	1-2
2.4	Piece Parts	1-2
2.5	Technical Support.....	1-3
2.6	Related Documents.....	1-3
3.0	Radio Model Information.....	1-4

Chapter 2 MAINTENANCE

1.0	Introduction	2-1
2.0	Preventive Maintenance	2-1
2.1	Inspection	2-1
2.2	Cleaning	2-1
3.0	Safe Handling of CMOS and LDMOS.....	2-2
4.0	General Repair Procedures and Techniques.....	2-2
5.0	Notes For All Schematics and Circuit Boards	2-5

Chapter 3 SERVICE AIDS

1.0	Recommended Test Tools.....	3-1
2.0	Test Equipment.....	3-2

SAFETY AND GENERAL INFORMATION

IMPORTANT INFORMATION ON SAFE AND EFFICIENT OPERATION

Read this information before using your radio.

The information provided in this document supersedes the general safety information contained in user guides published prior to July 2000. For information regarding radio use in a hazardous atmosphere please refer to the Factory Mutual (FM) Approval Manual Supplement or Instruction Card, which is included with radio models that offer this capability.

Radio Frequency (RF) Operational Characteristics

To transmit (talk) you must push the Push-To-Talk button; to receive (listen) you must release the Push-To-Talk button. When the radio is transmitting, it generates radio frequency (RF) energy; when it is receiving, or when it is off, it does not generate RF energy.

PORTABLE RADIO OPERATION AND EME EXPOSURE

Your Motorola radio is designed to comply with the following national and international standards and guidelines regarding exposure of human beings to radio frequency electromagnetic energy:

- United States Federal Communications Commission, Code of Federal Regulations; 47 CFR part 2 sub-part J
- American National Standards Institute (ANSI) / Institute of Electrical and Electronic Engineers (IEEE) C95. 1-1992
- Institute of Electrical and Electronic Engineers (IEEE) C95.1-1999 Edition
- National Council on Radiation Protection and Measurements (NCRP) of the United States, Report 86, 1986
- International Commission on Non-Ionizing Radiation Protection (ICNIRP) 1998
- Ministry of Health (Canada) Safety Code 6. Limits of Human Exposure to Radiofrequency Electromagnetic Fields in the Frequency Range from 3 kHz to 300 GHz, 1999
- Australian Communications Authority Radiocommunications (Electromagnetic Radiation - Human Exposure) Standard 1999 (applicable to wireless phones only)

To assure optimal radio performance and make sure human exposure to radio frequency electromagnetic energy is within the guidelines set forth in the above standards, always adhere to the following procedures:

Phone operation

When placing or receiving a phone call, hold your phone as you would a wireline telephone. Speak directly into the microphone.

Two-way radio operation

When using your radio hold the radio in a vertical position with the microphone 2.5 to 5 cm away from the lips.

Body-worn operation

To maintain compliance with FCC RF exposure guidelines, if you wear a radio on your body when transmitting, always place the radio in a Motorola approved clip, holder, holster, case, or body harness for this product. Use of non-Motorola-approved body worn accessories may exceed FCC RF exposure guidelines. If you do not use a Motorola approved body-worn accessory and are not using the radio in the intended use positions along side of the head in the phone mode or in front of the face in the two-way radio mode, then ensure the antenna and radio is kept the following minimum distances from the body when transmitting:

- Phone or Two-way radio mode: 2.5 cm (one inch)
- Data operation using any data feature with or without an accessory cable: 2.5 cm (one inch) .

Antenna Care

Use only the supplied or an approved replacement antenna. Unauthorized antennas, modifications, or attachments could damage the radio and may violate FCC regulations.

DO NOT hold the antenna when the radio is "IN USE". Holding the antenna affects call quality and may cause the radio to operate at a higher power level than needed.

Approved Accessories

For a list of approved Motorola accessories please contact your dealer or local Motorola representative.

ELECTROMAGNETIC INTERFERENCE/COMPATIBILITY

NOTE Nearly every electronic device is susceptible to electromagnetic interference (EMI) if inadequately shielded, designed, or alternately configured for electromagnetic compatibility.

Facilities

To avoid electromagnetic interference and/or compatibility conflicts, turn off your radio in any facility where posted notices instruct you to do so. Hospitals or health care facilities may be using equipment that is sensitive to external RF energy.

Aircraft

When instructed to do so, turn off your radio when on board an aircraft. Any use of a radio must be in accordance with applicable regulations per airline crew instructions.

Medical Devices

Pacemakers

The Health Industry Manufacturers Association recommends that a minimum separation of 15 cms (6 inches) be maintained between a handheld wireless radio and a pacemaker. These recommendations are consistent with those of the U.S. Food and Drug Administration.

Persons with pacemakers should:

- ALWAYS keep the radio more than 15 cms (6 inches) from their pacemaker when the radio is turned ON.
- not carry the radio in the breast pocket.
- use the ear opposite the pacemaker to minimize the potential for interference.
- turn the radio OFF immediately if you have any reason to suspect that interference is taking place.

Hearing Aids

Some digital wireless radio products may interfere with some hearing aids. In the event of such interference, you may want to consult your hearing aid manufacturer to discuss alternatives.

Other Medical Devices

If you use any other personal medical device, consult the manufacturer of your device to determine if it is adequately shielded from RF energy. Your physician may be able to assist you in obtaining this information.

Safety and General

Use While Driving

Check the laws and regulations on the use of radios in the area where you drive. Always obey them.

When using your radio while driving, please:

- Give full attention to driving and to the road.
- Use hands-free operation, if available.
- Pull off the road and park before making or answering a call if driving conditions so require.

OPERATIONAL WARNINGS

For Vehicles With An Air Bag



WARNING: Do not place a portable radio in the area over an air bag or in the air bag deployment area. Air bags inflate with great force. If a portable radio is placed in the air bag deployment area and the air bag inflates, the radio product may be propelled with great force and cause serious injury to occupants of vehicle.

NOTE

The areas with potentially explosive atmospheres referred to above include fueling areas such as below decks on boats, fuel or chemical transfer or storage facilities, areas where the air contains chemicals or particles, such as grain, dust or metal powders, and any other area where you would normally be advised to turn off your vehicle engine. Areas with potentially explosive atmospheres are often but not always posted.

Potentially Explosive Atmospheres



WARNING: Turn off your radio prior to entering any area with a potentially explosive atmosphere, unless it is a radio type especially qualified for use in such areas as "Intrinsically Safe" (for example, Factory Mutual, CSA, UL or CENELEC Approved). Do not remove, install, or charge batteries in such areas. Sparks in a potentially explosive atmosphere can cause an explosion or fire resulting in bodily injury or even death.

Blasting Caps And Areas



WARNING: To avoid possible interference with blasting operations, turn off your radio when you are near electrical blasting caps, in a "blasting area" or in areas posted "Turn off two-way radio". Obey all signs and instructions.

OPERATIONAL CAUTIONS

Antennas

Do not use any portable radio that has a damaged antenna. If a damaged antenna comes into contact with your skin, a minor burn can result.

Batteries

All batteries can cause property damage and/or bodily injury such as burns if a conductive material such as jewellery, keys, or beaded chains touch exposed terminals. The conductive material may complete an electrical circuit (short circuit) and become quite hot. Exercise care in handling any charged battery, particularly when placing it inside a pocket, purse, or other container with metal objects.

MOBILE RADIO OPERATION AND EME EXPOSURE

To assure optimal radio performance and that human exposure to radio frequency electromagnetic energy is within the guidelines referenced earlier in this document, transmit only when people outside the vehicle are at least the minimum lateral distance away from a properly installed, externally-mounted antenna. Table 1 lists the minimum distance for several different ranges of rated radio power.

Table 1: Table 1 Rated Power and Lateral Distance

Radiated Power of Vehicle-installed Mobile Two-way	Minimum Lateral Distance From Transmitting
Less than 7 Watts	20 cm (8 Inches)

Table 1: Table 1 Rated Power and Lateral Distance

Radiated Power of Vehicle-installed Mobile Two-way	Minimum Lateral Distance From Transmitting
7 to 15 Watts	30 cm (1 Ft)
16 to 50 Watts	60 cm (2 Ft)
More than 50 Watts	90 cm (3 Ft)

ANTENNA INSTALLATION

Mobile Antennas

Recommended mobile antenna installations are limited to metal body vehicles at the centre of the roof and centre of the trunk deck locations.

The antenna installation must additionally be in accordance with:

- a) The requirements of the antenna manufacturer/supplier
- b) Instructions in the Radio Installation Manual

Fixed Site Antennas

Mobile radio equipment is sometimes installed at a fixed location and operated as a control station or as a fixed unit. In such cases the antenna installation must comply with the following requirements in order to assure optimal performance and make sure human exposure to radio frequency electromagnetic energy is within the guidelines set forth in the above standards:

- The antenna must be mounted outside the building
- Mount the antenna on a tower if at all possible
- If the antenna is to be mounted on a building then it must be mounted on the roof.

As with all fixed site antenna installations, it is the responsibility of the licensee to manage the site in accordance with applicable regulatory requirements and may require additional compliance actions such as site survey measurements, signage, and site access restrictions in order to insure that exposure limits are not exceeded.

Chapter 1

INTRODUCTION

1.0 Scope of Manual

This manual is intended for use by service technicians familiar with similar types of equipment. It contains service information required for the equipment described and is current as of the printing date. Changes which occur after the printing date may be incorporated by a complete Manual revision or alternatively as additions.

NOTE Before operating or testing these units, please read the Safety Information Section in the front of this manual.

2.0 Warranty and Service Support

Motorola offers long term support for its products. This support includes full exchange and/or repair of the product during the warranty period, and service/ repair or spare parts support out of warranty. Any "return for exchange" or "return for repair" by an authorised Motorola Dealer must be accompanied by a Warranty Claim Form. Warranty Claim Forms are obtained by contacting an Authorised Motorola Dealer.

2.1 Warranty Period and Return Instructions

The terms and conditions of warranty are defined fully in the Motorola Dealer or Distributor or Reseller contract. These conditions may change from time to time and the following notes are for guidance purposes only.

In instances where the product is covered under a "return for replacement" or "return for repair" warranty, a check of the product should be performed prior to shipping the unit back to Motorola. This is to ensure that the product has been correctly programmed or has not been subjected to damage outside the terms of the warranty.

Prior to shipping any radio back to the appropriate Motorola warranty depot, please contact Customer Resources (Please see page 2 and page 3 in this Chapter). All returns must be accompanied by a Warranty Claim Form, available from your Customer Services representative. Products should be shipped back in the original packaging, or correctly packaged to ensure no damage occurs in transit.

2.2 After Warranty Period

After the Warranty period, Motorola continues to support its products in two ways.

1. Motorola's Radio Aftermarket and Accessory Division (AAD) offers a repair service to both end users and dealers at competitive prices.
2. AAD supplies individual parts and modules that can be purchased by dealers who are technically capable of performing fault analysis and repair.

2.3 European Radio Support Centre (ERSC)

The ERSC Customer Information Desk is available through the following service numbers:

Austria:	06 60 75 41	Italy:	16 78 77 387
Belgium:	08 00 72 471	Luxemburg:	08 00 23 27
Denmark:	80 01 55 72	Netherlands:	60 22 45 13
Finland:	08 00 11 49 10	Norway:	80 01 11 15
France:	05 90 30 90	Portugal:	05 05 49 35 70
Germany:	0800 1875240	Spain:	90 09 84 902
Greece:	00 80 04 91 29 020	Sweden:	02 07 94 307
UK:	08 00 96 90 95	Switzerland:	1 55 30 82
Ireland:	18 00 55 50 21	Iceland:	80 08 147

Or dial Customer Care Centre:

Tel: +49 6128 70 2618

Please use these numbers for repair enquiries only.

2.4 Piece Parts

Some replacement parts, spare parts, and/or product information can be ordered directly. If a complete Motorola part number is assigned to the part, it is available from Motorola Radio Aftermarket and Accessory Division (AAD). If no part number is assigned, the part is not normally available from Motorola. If the part number is appended with an asterisk, the part is serviceable by Motorola Depot only. If a parts list is not included, this generally means that no user-serviceable parts are available for that kit or assembly.

All enquiries should be directed to your local **Technical Support Team**.

2.5 Technical Support

Motorola Product Services is available to assist the dealer/distributors in resolving any malfunctions which may be encountered.

UK/Ireland - Richard Russell
 Telephone: +44 (0) 1256 488 082
 Fax: +44 01256 488 080
 Email: BRR001@email.mot.com

France - Armand Roy
 Telephone: +33 1 6929 5715
 Fax: +33 1 6929 5904
 Email: armand.roy@motorola.com

East Europe, Turkey and Central Asia
 Siggy Punzenberger
 Telephone: +49 (0) 6128 70 2342
 Fax: +49 (0) 6128 95 1096
 Email: TFG003@email.mot.com

Italy - Ugo Gentile
 Telephone: +39 0 2822 0325
 Fax: +39 0 2822 0334
 Email: C13864@email.mot.com

Scandinavia
 Telephone: +46 8 735 9282
 Fax: +46 8 735 9280

Middle East & Africa - Ralph Schubert
 Telephone: +33 (0) 4 4230 5887
 Fax: +33 (0) 4 4230 4784
 Email: ralph.schubert@motorola.com

Central Europe (Germany, Benelux, Austria & Switzerland) - Customer Connect
 Telephone: +49 (0) 6128 70 2266
 Fax: +49 (0) 6128 95 1685
 Email: cgiss.emea@europe.mot.com

2.6 Related Documents

The following documents are directly related to the use and maintainability of this product.

Title	Language	Part Number
GM100 Series Product Manual	English	ENLN4147
GM300 Series Product Manual	English	ENLN4137
	German	ENLN4138
	French	ENLN4139
	Italian	ENLN4140
	Spanish	ENLN4141
GM600/GM1200 Series Product Manual	Russian	ENLN4142
	English	ENLN4143
	German	ENLN4144
	French	ENLN4145
	Russian	ENLN4146

3.0 Radio Model Information

The model number and serial number are located on a label attached to the back of your radio. You can determine the RF output power, frequency band, protocols, and physical packages. The example below shows one mobile radio model number and its specific characteristics.

Table 1-1 Radio Model Number (Example: MDM25KHC9AN1AE)

	Type of Unit	Model Series	Freq. Band	Power Level	Physical Packages	Channel Spacing	Protocol	Feature Level	Model Revision	Model Package
MD = Motorola Internal Use ↑	M ↑ M = Mobile	25	K VHF (136-174MHz)	H 1-25W	C GM140, GM340, GM640	9 Program- mable	AN Conventional 5 Tone	1 GM140 GM340 GM640	A	E
			R UHF 1 (403-470MHz)	K 25-40W 40-60W	N GM380, GM1280		AA Conventional MDC	O Databox (5Tone)		
			S UHF 2 (450-527MHz)		F GM160 GM360 GM660		CK MPT	5 GM160 GM360 GM660		
			B LB1 29-36MHz		A Databox			8 GM380 GM1280		
			C LB2 36-42MHz					7 Databox (MPT)		
			D LB3 42-50MHz							

Chapter 2

MAINTENANCE

1.0 Introduction

This chapter of the manual describes:

- preventive maintenance
- safe handling of CMOS devices
- repair procedures and techniques

2.0 Preventive Maintenance

The radios do not require a scheduled preventive maintenance program; however, periodic visual inspection and cleaning is recommended.

2.1 Inspection

Check that the external surfaces of the radio are clean, and that all external controls and switches are functional. It is not recommended to inspect the interior electronic circuitry.

2.2 Cleaning

The following procedures describe the recommended cleaning agents and the methods to be used when cleaning the external and internal surfaces of the radio. External surfaces include the front cover, housing assembly, and battery case. These surfaces should be cleaned whenever a periodic visual inspection reveals the presence of smudges, grease, and/or grime.

NOTE Internal surfaces should be cleaned only when the radio is disassembled for servicing or repair.

The only recommended agent for cleaning the external radio surfaces is a 0.5% solution of a mild dishwashing detergent in water. The only factory recommended liquid for cleaning the printed circuit boards and their components is isopropyl alcohol (70% by volume).



CAUTION: The effects of certain chemicals and their vapors can have harmful results on certain plastics. Aerosol sprays, tuner cleaners, and other chemicals should be avoided.

1. **Cleaning External Plastic Surfaces**
The detergent-water solution should be applied sparingly with a stiff, non-metallic, short-bristled brush to work all loose dirt away from the radio. A soft, absorbent, lintless cloth or tissue should be used to remove the solution and dry the radio. Make sure that no water remains entrapped near the connectors, cracks, or crevices.
2. **Cleaning Internal Circuit Boards and Components**
Isopropyl alcohol may be applied with a stiff, non-metallic, short-bristled brush to dislodge embedded or caked materials located in hard-to-reach areas. The brush stroke should direct the dislodged material out and away from the inside of the radio. Make sure that controls or tunable components are not soaked with alcohol. Do not use high-pressure air to hasten the drying process since this could cause the liquid to collect in unwanted places. Upon completion of the cleaning process, use a soft, absorbent, lintless cloth to dry the area. Do not brush or apply any isopropyl alcohol to the frame, front or back cover.

NOTE Always use a fresh supply of alcohol and a clean container to prevent contamination by dissolved material (from previous usage).

3.0 Safe Handling of CMOS and LDMOS

Complementary metal-oxide semiconductor (CMOS) devices are used in this family of radios. CMOS characteristics make them susceptible to damage by electrostatic or high voltage charges. Damage can be latent, resulting in failures occurring weeks or months later. Therefore, special precautions must be taken to prevent device damage during disassembly, troubleshooting, and repair.

Handling precautions are mandatory for CMOS circuits and are especially important in low humidity conditions. DO NOT attempt to disassemble the radio without first referring to the CMOS CAUTION paragraph in the Disassembly and Reassembly section of the manual.

4.0 General Repair Procedures and Techniques

Parts Replacement and Substitution

When damaged parts are replaced, identical parts should be used. If the identical replacement component is not locally available, check the parts list for the proper Motorola part number and order the component from the nearest Motorola Communications parts center listed in the "Piece Parts" section of this manual.

Rigid Circuit Boards

The family of radios uses bonded, multi-layer, printed circuit boards. Since the inner layers are not accessible, some special considerations are required when soldering and unsoldering components. The through-plated holes may interconnect multiple layers of the printed circuit. Therefore, care should be exercised to avoid pulling the plated circuit out of the hole.

When soldering near the 18-pin and 40-pin connectors:

- avoid accidentally getting solder in the connector.
- be careful not to form solder bridges between the connector pins
- closely examine your work for shorts due to solder bridges.

Chip Components

Use either the RLN4062 Hot-Air Repair Station or the Motorola 0180381B45 Repair Station for chip component replacement. When using the 0180381B45 Repair Station, select the TJ-65 mini-thermojet hand piece. On either unit, adjust the temperature control to 370 °C (700 °F), and adjust the airflow to a minimum setting. Airflow can vary due to component density.

To remove a chip component:

1. Use a hot-air hand piece and position the nozzle of the hand piece approximately 0.3 cm (1/8") above the component to be removed.
2. Begin applying the hot air. Once the solder reflows, remove the component using a pair of tweezers.
3. Using a solder wick and a soldering iron or a power desoldering station, remove the excess solder from the pads.

To replace a chip component using a soldering iron:

1. Select the appropriate micro-tipped soldering iron and apply fresh solder to one of the solder pads.
2. Using a pair of tweezers, position the new chip component in place while heating the fresh solder.
3. Once solder wicks onto the new component, remove the heat from the solder.
4. Heat the remaining pad with the soldering iron and apply solder until it wicks to the component. If necessary, touch up the first side. All solder joints should be smooth and shiny.

To replace a chip component using hot air:

1. Use the hot-air hand piece and reflow the solder on the solder pads to smooth it.
2. Apply a drop of solder paste flux to each pad.
3. Using a pair of tweezers, position the new component in place.
4. Position the hot-air hand piece approximately 0.3 cm (1/8") above the component and begin applying heat.
5. Once the solder wicks to the component, remove the heat and inspect the repair. All joints should be smooth and shiny.

Shields

Removing and replacing shields will be done with the R1070 station with the temperature control set to approximately 215°C (415°F) [230°C (445°F) maximum].

To remove the shield:

1. Place the circuit board in the R1070 circuit board holder.
2. Select the proper heat focus head and attach it to the heater chimney.
3. Add solder paste flux around the base of the shield.
4. Position the shield under the heat-focus head.
5. Lower the vacuum tip and attach it to the shield by turning on the vacuum pump.
6. Lower the focus head until it is approximately 0.3 cm (1/8") above the shield.
7. Turn on the heater and wait until the shield lifts off the circuit board.
8. Once the shield is off, turn off the heat, grab the part with a pair of tweezers, and turn off the vacuum pump.
9. Remove the circuit board from the R1070 circuit board holder.

To replace the shield:

1. Add solder to the shield if necessary, using a micro-tipped soldering iron.
2. Next, rub the soldering iron tip along the edge of the shield to smooth out any excess solder. Use solder wick and a soldering iron to remove excess solder from the solder pads on the circuit board.
3. Place the circuit board back in the R1070 circuit board holder.
4. Place the shield on the circuit board using a pair of tweezers.
5. Position the heat-focus head over the shield and lower it to approximately 0.3 cm (1/8") above the shield.
6. Turn on the heater and wait for the solder to reflow.
7. Once complete, turn off the heat, raise the heat-focus head and wait approximately one minute for the part to cool.
8. Remove the circuit board and inspect the repair. No cleaning should be necessary.

5.0 Notes For All Schematics and Circuit Boards

* Component is frequency sensitive. Refer to the Electrical Parts List for value and usage.

1. Unless otherwise stated, resistances are in Ohms ($k = 1000$), and capacitances are in picofarads (pF) or microfarads (μF).
2. DC voltages are measured from point indicated to chassis ground using a Motorola DC multimeter or equivalent. Transmitter measurements should be made with a $1.2 \mu\text{H}$ choke in series with the voltage probe to prevent circuit loading.

3. Interconnect Tie Point Legend:

16_8MHz	16.8MHz Reference Frequency
3V3	Regulated 3.3V Supply Voltage for Voice Storage
5V	Regulated 5V Supply Voltage for RF Circuitry
5V	Regulated 5V Supply Voltage (Control Head)
5V RF	Regulated 5V Supply Voltage for RF Circuitry
5V SOURCE	5V Signal to Switch On Control Head
5VD	Regulated 5V Supply Voltage for Digital Circuitry
9V3	Regulated 9.3V Supply Voltage
9V3FLT	Filtered 9.3V Supply Voltage
A+	13.2V Supply Voltage
ADDR	*P Address Lines
AN	Analog Lines to Analog to Digital Converter
ANALOG INPUT 2	External Keypad Matrix Column Signal
ANALOG INPUT 3	External Keypad Matrix Row Signal
BATTERY VOLTAGE	Battery Voltage Sense Line
BL A GREEN	Back Light Anode Green
BL A RED	Back Light Anode Red
BL GREEN	Green Back Light Control
BL K GREEN	Back Light Cathode Green
BL K RED	Back Light Cathode Red
BL KP Green	Green Keypad Back Light Control
BL KP RED	Red Keypad Back Light Control
BL LCD GREEN	Green Display Back Light Control
BL LCD RED	Red Display Back Light Control
BL RED	Red Back Light Control
BOOT CNTRL	Bootstrap Mode Enable Signal
BOOT MODE	Boot Mode Select
BOOT PWR ON	Control Head Switch On Signal
BOOT SCI RX	Serial Communication Interface Receive Line
BOOT SCI TX	Serial Communication Interface Transmit Line
BOOT VPP	Boot Mode Select
BUS+	Bi-directional Serial Communication Line
BWSELECT	Signal to select between the Ceramic Filter Pairs

CH ACT	Channel Activity Indicator Signal (Fast Squelch)
CH KP ID	Control Head Keypad ID (Data) Lines
CH REQUEST	Control Head Request from Control Head *P
CLK	Clock Signal
CNTLVLTG	PA Power Control Voltage
CNTR AUDIO	Audio Lines of the Controller
COL x	Keypad Matrix Column x
CSX	Chip Select Line PCIC / FRACN
DATA	Data Signal
DC POWER ON	Electronic Switching On or Off of the Radio's Voltage Regulators
DISCAUDIO	Audio Output Signal from the Receiver IC
ECLK	Clock (not used)
EE CS	EEPROM Chip Select
EMERGENCY CONTROL	Emergency Line to switch on the Radio's Voltage Regulators
EXP BD REQ	Service Request Line from Expansion Board
EXP1 CS	Expansion Board Chip Select 1
EXP2 CS	Expansion Board Chip Select 2
EXT KP COL	External Keypad Matrix Column Signal
EXT KP ROW	External Keypad Matrix Row Signal
EXT MIC	External (from Accessory Connector) Microphone Input
EXT SWB+	External Switched 13.2V Supply Voltage
F1200	Interrupt Line from ASFIC CMP
FECTRL 1	Control Voltage for Front End Filter
FECTRL 2	Control Voltage for Front End Attenuator Switch
FLASH CE	Flash Chip Select
FLASH OE	Flash Output Enable
FLAT RX SND	Option Board Audio Output Signal
FLAT TX RTN	Flat TX Input from Option Board and Accessory Connector
FLT A+	Filtered 13.2 V Supply Voltage
GP x IN	General Purpose Input x
GP x IN ACC y	General Purpose Input x from Accessory Connector Pin y
GP x IN OUT ACC y	General Purpose Input /Output x from Accessory Connector Pin y
GP x OUT	General Purpose Output x
GP x OUT ACC y	General Purpose Input x from Accessory Connector Pin y
GPIO	General Purpose Input Output Lines
HANDSET AUDIO	Handset Audio Output
HOOK	Hang-up Switch Input
HSIO	High Speed Clock In / Data Out
IF	First Intermediate Frequency Signal
IGNITION CONTROL	Ignition Line to switch on the Radio's Voltage Regulators

IN 5V RF REG	Supply Voltage for 5V Regulator in RF Section
INT KP COL	Internal Keypad Matrix Column Signal
INT KP ROW	Internal Keypad Matrix Row Signal
INT MIC	Internal (from Control Head) Microphone Input
INT SWB	Internal Switched 13.2V Supply Voltage
INT SWB+	Internal Switched 13.2V Supply Voltage
IRQ	Interrupt Request from Control Head
K9V1	9.1V in Transmit Mode
KEYPAD ID	Keypad Identification Line
LCD A0	LCD Control / Display Data Select
LCD CS	LCD Chip Select
LCD DATA	LCD Data Lines
LCD E RD	LCD Enable Read
LCD RW WR	LCD Read Write Control
LED CNTRL	LED Control Lines
LED GREEN	Green LED Control
LED RED	Red LED Control
LED YELLOW	Yellow LED Control
LOCK	Lock Detect Signal from Synthesizer
LSIO	Low Speed Clock In / Data Out
LVZIF CS	LVZIF Chip Select (not used)
MIC	Microphone Input
MISO	Serial Peripheral Interface Receive Line
MODIN	Modulation Signal into the Synthesizer
MOSBIAS 2	PA Bias Voltage for second Stage
MOSBIAS 3	PA Bias Voltage for third Stage
NOISE BLNKR	Noise Blanker Enable (Low Band only)
ON OFF CONTROL	Service Request Line from Control Head / Manual Switching On of the Radio's Voltage Regulators
ON OFF SENSE (Control Head)	On Off Sense Line to Control Head *P
ON OFF SENSE (Controller)	Service Request Line from Control Head
OPT CS	Option Board Chip Select
OPT PTT	PTT from Option Board
PA PWR SET	ASFIC Output Voltage to set the Transmitter Power
PA SWB	Switches Supply Voltage for PA Current Control Circuitry
PASUPVLTG	13.2 V Supply Voltage of the Transmitter PA
PCIC MOSBIAS 1	PA Bias Voltage for first Stage
PRESC	Prescaler Signal from VCO to Synthesizer
PTT IRDEC	Microphone PTT Input
PTT IRDECODER	Microphone PTT Input
R W	Read Write Signal for RAM / Flash

RAM CS	RAM Chip Select
RDY	Service Request Line from Option Board
REF CS	Reference Chip Select (not used)
RESET	Reset Line
ROW x	Keypad Matrix Row x
RSSI	Received Signal Strength Indicator
RX ADAPT	Flat TX Path Disable during Transmitter Key-up
RX AUD RTN	Option Board Input / Output of Receiver Audio Path
RX FLAT FILTERED AUDIO	Flat or Filtered Audio to Accessory Connector
RXIN	RF Signal from Antenna Switch into the Receiver
RXINJ	RF Signal from the VCO into the Mixer
SCI RX	Serial Communication Interface Receive Line
SCI TX	Serial Communication Interface Transmit Line
SPI	Serial Peripheral Interface Bus
SPKR-	Negative Audio PA Speaker Output
SPKR+	Positive Audio PA Speaker Output
SQ DET	Squelch Detect Signal
SYN	*P Clock Signal
TEMP SENSE	Temperature Sense Line for LCD
TEMPSENSE	Temperature Sense Line from PA to *P
TRB	TX/RX VCO Switch Signal
TX AUD RTN	Option Board Output to Transmit Audio Path
TX AUD SND	Microphone Audio to Option Board
TXINJ	RF Signal from the VCO into the Transmitter PA
U DRIVER	Supply Voltage for PA Driver
U PREDRIVER	Supply Voltage for PA Pre-driver
UNSW 5V	Permanent 5V Supply
URX SND	Filtered Audio Signal to Option Board
VAG	2.5V Reference Voltage for Analog Circuitry
VCBIAS 1	Switch Signal from Synthesizer
VCBIAS 2	Switch Signal from Synthesizer
VCOMOD	Modulation Signal into VCO
VCTRL	VCO Frequency Control Voltage
VDDA	Regulated 5V for Digital Circuitry in RF Section
VOLTAGE SENSE	Voltage Sense Line from LCD
VOLUME	Volume Pot Output
VOX	Voice Operated Transmit Level
VPP	Boot Mode Select
VS AUDIOSEL	Switch Signal to Enable Option Board Audio Output Signal
VS GAINSEL	Voice Storage Gain Select Line
VS INT	Voice Storage Interrupt Line

VS MIC	Voice Storage Audio Signal into Microphone Path
VS RAC	Voice Storage Row Address Clock Signal
VSF	Voltage Super Filtered (5V)
VSTBY	5V Supply for *P when the Radio is switched off

4-LAYER CIRCUIT BOARD DETAIL VIEWING
COPPER STEPS IN PROPER LAYER SEQUENCE

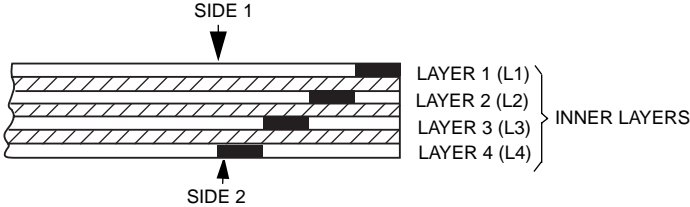

Chapter 3

SERVICE AIDS

1.0 Recommended Test Tools

Table 3-1 lists the service aids recommended for working on the radio. While all of these items are available from Motorola, most are standard workshop equipment items, and any equivalent item capable of the same performance may be substituted for the item listed.

Table 3-1 Service Aids

Motorola Part Number	Description	Application
RLN4460_	Portable Test Set	Enables connection to audio/accessory jack. Allows switching for radio testing.
RKN4081_	Programming Cable with Internal RIB	Includes radio interface box (RIB) capability.
RLN4853_	10 to 20 Pin Adapter	Connects RKN4081_ to the radio accessory connector.
RKN4083_	Mobile Programming/Test Cable	Connects radio to RIB (RLN4008_).
GTF374_	Program Cable	Connects RIB to Radio microphone input
RLN4008_	Radio Interface Box	Enables communications between radio and computer's serial communications adapter.
HLN8027_	Mini UHF to BNC Adaptor	Adapts radio antenna port to BNC cabling of test equipment.
GPN6133_	Power Supply	Provides the radio with power when bench testing.
EPN4040_	Wall-Mounted Power Supply	Used to supply power to the RIB (UK).
EPN4041_	Wall-Mounted Power Supply	Used to supply power to the RIB (Euro)
8180384J59	Housing Eliminator (short)	Test Fixture used to bench test the radio pcb
8180384L95	Housing Eliminator (short + top)	Test Fixture used to bench test the radio pcb. (Radio using pressure pads to retain pcb)
8180384J60	Housing Eliminator (medium)	Test Fixture used to bench test the radio pcb
8180384J61	Housing Eliminator (long)	Test Fixture used to bench test the radio pcb
3080369B71	Computer Interface Cable	Connects the RIB to the Computer (25-pin)
3080369B72	Computer Interface Cable	Connects the RIB to the Computer 9-pin (Use for IBM PC AT - other IBM models use the B71 cable above)
6686119B01	Removal Tool	Assists in the removal of radio control head.

2.0 Test Equipment

Table 3-2 lists test equipment required to service the radio and other two-way radios.

Table 3-2 Recommended Test Equipment

Motorola Part Number	Description	Characteristics	Application
R2600_NT	Comms System Analyzer (non MPT)	This monitor will substitute for items with an asterisk*	Frequency/deviation meter and signal generator for widerange troubleshooting and alignment
R2680_NT	Comms System Analyzer (MPT1327) to be ordered with RLN1022_ (H/W) RLN1023_ (S/W)	This monitor will substitute for items with an asterisk*.	Frequency/deviation meter and signal generator for widerange troubleshooting and alignment
*R1072_	Digital Multimeter		AC/DC voltage and current measurements
*R-1377_	AC Voltmeter	100 μ V to 300V, 5Hz - 1MHz, 10Megohm input impedance	Audio voltage measurements
WADN133	Delay Oscilloscope	2 Channel 40MHz bandwidth, 5mV/cm - 20 V/cm	Waveform measurements
R1440_ 0180305F17 0180305F31 0180305F39 RLN4610 T1013_	Wattmeter, Plug-in Elements Plug-in Elements Plug-in Elements Carry case RF Dummy Load	ThruLine 50-Ohm, \pm 5% accuracy 100W, 25 - 60MHz 25W, 100-250MHz 10W, 200-250MHz Wattmeter and 6 elements	Transmitter power output measurements
S1339_	RF Millivolt Meter	100mV to 3 VRF. 10kHz to 1.2GHz	RF level measurements
R1011_/220V	220V Power Supply	0 - 40V 0 - 40A	Programmable



Professional Radio

GM Series

LB1 (29.6 - 36.0MHz)

LB2 (36.0 - 42.0MHz)

LB3 (42.0 - 50.0MHz)

Computer Software Copyrights

The Motorola products described in this manual may include copyrighted Motorola computer programs stored in semiconductor memories or other media. Laws in the United States and other countries preserve for Motorola certain exclusive rights for copyrighted computer programs, including the exclusive right to copy or reproduce in any form, the copyrighted computer program. Accordingly, any copyrighted Motorola computer programs contained in the Motorola products described in this manual may not be copied or reproduced in any manner without the express written permission of Motorola. Furthermore, the purchase of Motorola products shall not be deemed to grant, either directly or by implication, estoppel or otherwise, any license under the copyrights, patents or patent applications of Motorola, except for the normal non-exclusive royalty-free license to use that arises by operation of law in the sale of a product.

Table of Contents

Chapter 1 MODEL CHART AND TECHNICAL SPECIFICATIONS

1.0 GM360 Model Chart.....	1-1
2.0 Technical Specifications	1-1

Chapter 2 THEORY OF OPERATION

1.0 Introduction	2-1
2.0 Low Band Receiver	2-2
2.1 Receiver Front-End	2-2
2.2 Front-End Band-Pass Filters & Pre-Amplifier	2-3
2.3 First Mixer	2-3
2.4 High Intermediate Frequency (IF) and Receiver Back End	2-3
2.5 Low Intermediate Frequency (IF) and Receiver Back End	2-4
2.6 "Extender" (Noise Blanker)	2-4
3.0 Low Band Transmitter Power Amplifier (PA) 25-60 W	2-5
3.1 Power Controlled Stage	2-5
3.2 Driver Stage.....	2-5
3.3 Final Stage	2-6
3.4 Antenna Switch.....	2-6
3.5 Harmonic Filter	2-6
3.6 Power Control	2-6
3.7 TX Safety Switch	2-6
4.0 Low Band Frequency Synthesis.....	2-7
4.1 Fractional-N Synthesizer	2-7
4.2 Voltage Controlled Oscillator (VCO)	2-9
4.3 Synthesizer Operation	2-10

Chapter 3 TROUBLESHOOTING CHARTS

1.0 Troubleshooting Flow Chart for Transmitter	3-1
2.0 Troubleshooting Flow Chart for Receiver (Sheet 1 of 2).....	3-2
2.1 Troubleshooting Flow Chart for Receiver (Sheet 2 of 2).....	3-3
3.0 Troubleshooting Flow Chart for Synthesizer.....	3-4
4.0 Troubleshooting Flow Chart for VCO	3-5

Chapter 4 Low Band PCB/SCHEMATICS/PARTS LISTS

1.0	Allocation of Schematics and Circuit Boards	4-1
1.1	Controller Circuits	4-1
2.0	LB1 25-60W PCB 8486206B06 / Schematics	4-3
2.1	LB1 25-60W PCB 8486206B06 Parts List	4-13
3.0	LB2 25-60W PCB 8486207B05 / Schematics	4-17
3.1	LB2 25-60W PCB 8486207B05 Parts List	4-27
4.0	LB3 25-60W PCB 8485908z03 / Schematics	4-31
4.1	LB3 25-60W PCB 8485908z03 Parts List.....	4-41

MODEL CHART AND TECHNICAL SPECIFICATIONS

1.0 GM360 Model Chart

GM Series Low Band 29-50 MHz				
Model				Description
MDM25BKF9AN5_E				GM360 LB1, 29.0-36.0 MHz, 25-60W, 255 Ch
MDM25CKF9AN5_E				GM360 LB2, 36.0-42.0 MHz, 25-60W, 255 Ch
MDM25DKF9AN5_E				GM360 LB3, 42.0-50.0 MHz, 25-60W, 255 Ch
Item				Description
X	X	X	GCN6114_	Control Head, GM360
X			IMUB6003_S	Field Replaceable Unit (Main Board) GM360
	X		IMUB6004_S	Field Replaceable Unit (Main Board) GM360
		X	IMUB6005_S	Field Replaceable Unit (Main Board) GM360
X	X	X	ENBN4056_	Packaging, Waris Mobile
X	X	X	HKN9402_	12V Power Cable
X	X	X	MDRMN4025_	Enhanced Compact Microphone
X	X	X	RLN4774_	3 Point Mount
X	X	X	6864110B81_	User Guide, GM360

X = Indicates one of each is required

2.0 Technical Specifications

Data is specified for +25°C unless otherwise stated.

General Specifications	
Channel Capacity GM360	255
Power Supply	13.2Vdc (10.8 - 15.6Vdc)
Dimensions: H x W x D (mm) Height excluding knobs	GM360 59mm x 179mm x 250mm (add 9mm for Volume Knob)
Weight	2064gr
Sealing:	Withstands rain testing per MIL STD 810 C/D /E and IP54
Shock and Vibration:	Protection provided via impact resistant housing exceeding MIL STD 810-C/D /E and TIA/EIA 603
Dust and Humidity:	Protection provided via environment resistant housing exceeding MIL STD 810 C/D /E and TIA/EIA 603

Transmitter	LB1	LB2	LB3
*Frequencies - Full Bandsplit	LB1 29.7-36.0 MHz	LB2 36.0-42.0 MHz	LB2 42.0-50.0 MHz
Channel Spacing	12.5/20/25 kHz	12.5/20/25 kHz	12.5/20/25 kHz
Frequency Stability (-30°C to +60°C, +25° Ref.)	±5.0 ppm	±5.0 ppm	±5.0 ppm
Power	25-60W	25-60W	25-60W
Modulation Limiting	±2.5 @ 12.5 kHz ±4.0 @ 20 kHz ±5.0 @ 25 kHz	±2.5 @ 12.5 kHz ±4.0 @ 20 kHz ±5.0 @ 25 kHz	±2.5 @ 12.5 kHz ±4.0 @ 20 kHz ±5.0 @ 25 kHz
FM Hum & Noise	-40 dB @ 12.5kHz -45 dB @ 20/25kHz	-40 dB @ 12.5kHz -45 dB @ 20/25kHz	-40 dB @ 12.5kHz -45 dB @ 20/25kHz
Conducted/Radiated Emission (ETS)	-26 dBm	-26 dBm	-26 dBm
Adjacent Channel Power	-60 dB @ 12.5 kHz -70 dB @ 25 kHz	-60 dB @ 12.5 kHz -70 dB @ 25 kHz	-60 dB @ 12.5 kHz -70 dB @ 25 kHz
Audio Response (300 - 3000 Hz)	+1 to -3 dB	+1 to -3 dB	+1 to -3 dB
Audio Distortion @ 1000Hz, 60% Rated Maximum Deviation	<3% typical	<3% typical	<3% typical

Receiver	LB1	LB2	LB3
*Frequencies - Full Bandsplit	LB1 29.7-36.0 MHz	LB2 36.0-42.0 MHz	LB2 42.0-50.0 MHz
Channel Spacing	12.5/20/25 kHz	12.5/20/25 kHz	12.5/20/25 kHz
Sensitivity (12 dB SINAD)	0.30 µV (0.22 µV typical)	0.30 µV (0.22 µV typical)	0.30 µV (0.22 µV typical)
Intermodulation (ETS)	>65 dB	>65 dB	>65 dB
Adjacent Channel Selectivity (ETS)	65 dB @ 12.5 kHz 75 dB @ 20 kHz 80 dB @ 25 kHz	65 dB @ 12.5 kHz 75 dB @ 20 kHz 80 dB @ 25 kHz	65 dB @ 12.5 kHz 75 dB @ 20 kHz 80 dB @ 25 kHz
Spurious Rejection (ETS)	75 dB @ 12.5 kHz 80 dB @ 20/25 kHz	75 dB @ 12.5 kHz 80 dB @ 20/25 kHz	75 dB @ 12.5 kHz 80 dB @ 20/25 kHz
Rated Audio	3W Internal 13W External	3W Internal 13W External	3W Internal 13W External
Audio Distortion @ Rated Audio	<3% typical	<3% typical	<3% typical
Hum & Noise	-40 dB @ 12.5 kHz -45 dB @ 20/25 kHz	-40 dB @ 12.5 kHz -45 dB @ 20/25 kHz	-40 dB @ 12.5 kHz -45 dB @ 20/25 kHz
Audio Response (300 - 3000Hz @ 20/25kHz) (300 - 2550Hz @ 12.5kHz)	+1 to -3 dB	+1 to -3 dB	+1 to -3 dB
Conducted Spurious Emission (ETS)	-57 dBm <1 GHz -47 dBm >1 GHz	-57 dBm <1 GHz -47 dBm >1 GHz	-57 dBm <1 GHz -47 dBm >1 GHz

*Availability subject to the laws and regulations of individual countries.

Chapter 2

THEORY OF OPERATION

1.0 Introduction

This Chapter provides a detailed theory of operation for the LowBand circuits in the radio. For details of the theory of operation and trouble shooting for the the associated Controller circuits refer to the Controller Section of this manual.

2.0 Low Band Receiver

2.1 Receiver Front-End

The low band receiver is bandsplit into three ranges depending on radio model, covering frequencies from 29.7 to 36.0 MHz, 36.0 to 42.0 MHz, or 42.0 to 50.0 MHz. The circuitry of the three models is identical except for component value differences. The receiver consists of five major blocks: front-end bandpass filters and pre-amplifier, first mixer, high-IF and blanker switches, low-IF and receiver back-end, and “Extender” (noise blanker). Two fixed-tuned bandpass filters perform antenna signal pre-selection. A cross over quad diode mixer converts the signal to the high - IF of 10.7 MHz. High-side first injection is used.

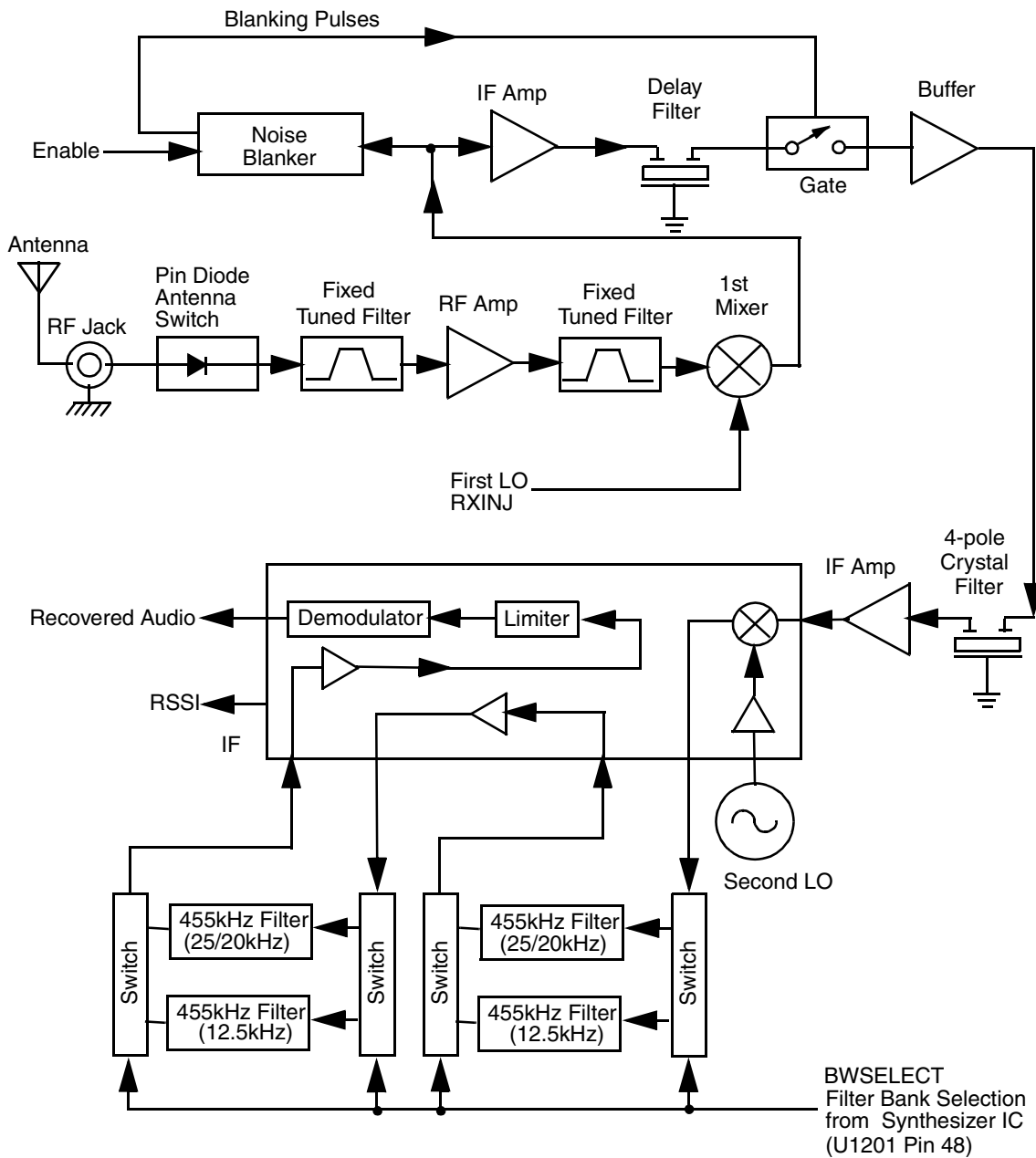

Figure 2-1 Low Band Receiver Block Diagram

There are two 2-pole 10.7 MHz crystal filters in the high-IF section and two switched pairs of 455 kHz ceramic filters in the low-IF section to provide the required adjacent channel selectivity. The second IF at 455 kHz is mixed, amplified and demodulated in the IF IC. The processing of the demodulated audio signal is performed by an audio processing IC located in the controller section.

2.2 Front-End Band-Pass Filters & Pre-Amplifier

The received signal from the radio's antenna connector is first routed through the harmonic filter and antenna switch, which are part of the RF power amplifier circuitry, before being applied to the receiver 5-pole antenna filter (L1001-L1005 and associated components). This filter configuration provides more rapid attenuation above the passband to provide better rejection of the half-IF spurious response. A dual hot carrier diode (D1001) limits any inband signal to 0 dBm to prevent damage to the RF pre-amplifier

The RF pre-amplifier is an SMD device (Q1001) with collector-base feedback to stabilize gain, impedance, and intermodulation. Transistor Q1002 compares the voltage drop across resistor R1005 with a fixed base voltage from divider R1006 and R1007, and adjusts the base current of Q1001 as necessary to maintain its collector current constant at 25 mA. Operating voltage is from the regulated 9.3V supply (9V3). During transmit, 9.1 volts (9T1) turns on both transistors in U1001, turning off Q1003 and therefore Q1001-2. This protects the RF pre-amplifier from excessive dissipation during transmit mode.

A second 5-pole fixed-tuned bandpass filter provides additional filtering of the amplified signal. This filter configuration also provides steeper attenuation above its passband for best half-IF attenuation.

2.3 First Mixer

The signal coming from the front-end is converted to the high-IF frequency of 10.7 MHz using a cross over quad diode mixer (U1051). The high-side injection signal (RXINJ) from the frequency synthesizer circuitry is filtered by a 7-pole low-pass filter (L1012-14 and associated circuitry) which removes second harmonic content from the injection signal and improves half-IF rejection. The 50-ohm output of the first mixer is applied to the input of the high-IF circuit block.

2.4 High Intermediate Frequency (IF) and Blanker Switches

The first mixer IF output signal (IF) is applied to a diplexer network consisting of L1101, L1111 and associated components. This network has three functions: it terminates the mixer output at frequencies other than 10.7 MHz into 51-ohm resistor R1101; it matches the 50-ohm mixer output to the first IF amplifier (Q1101) input; and it provides bandpass filtering at 10.7 MHz to prevent the 5.35 MHz half-IF component of the mixer output from creating a second harmonic at 10.7 MHz in Q1101, which degrades half-IF rejection.

The IF amplifier Q1101 uses ac and dc feedback to stabilize gain and quiescent current (approximately 28 mA). Operating voltage is from the regulated 9.3V supply (9V3). Its output is applied to a 10.7 MHz ceramic filter FL1101 which has a 3 dB bandwidth of 270 kHz and provides a time delay of 2.6 usec. This delay allows enough time for the "Extender" to respond to impulse noise present at the input of Q1101 and operate the blanker switches Q1102 and Q1103, muting the IF signal for the duration of the noise pulse. L1104 and L1105 also provide additional selectivity and time delay. Operation of the "Extender" circuit is explained in Section 8.5 below.

When the blanker switches turn "on" to mute the IF signal, they momentarily change the impedance of resonant circuits L1104 and L1105 from high to very low. This abrupt impedance change, if

presented to the high-Q crystal filters FL1102 and FL1103, would cause ringing of the filter response, stretching an otherwise narrow impulse into a long and audible output waveform. Therefore, source follower stage Q1104 isolates the blanker switches from the crystal filters, providing a consistent source impedance via matching network L1106, L1107 and associated components. Q1104 has unity voltage gain in this configuration.

Crystal filters FL1102 and FL1103 are 2-pole, 10.7 MHz units configured to provide an overall 4-pole response having a 3 dB bandwidth of approximately 12 kHz. The output is amplified by second IF amplifier Q1106 and applied to the low-IF circuitry, pin 1 of IF IC (U1103). A dual hot carrier diode (D1101) limits the amplifier output voltage swing to prevent overdriving the IF IC at RF input levels above -27 dBm.

2.5 Low Intermediate Frequency (IF) and Receiver Back End

The 10.7 MHz high-IF signal from the second IF amplifier feeds the IF IC (U1103) at pin1. Within the IF IC, the 10.7 MHz high -IF signal mixes with the 10.245 MHz second local oscillator (2nd LO) to produce the low-IF signal at 455 kHz. The 2nd LO frequency is determined by crystal Y1101. The low -IF signal is amplified and filtered by external pairs of 455 kHz ceramic filters (FL1105 and FL1107 for 20 kHz channel spacing, or FL1104 and FL1106 for 12.5 kHz channel spacing). Selection of the appropriate filter pair is accomplished by U1101 and U1102, controlled by the BWSELECT line from pin 48 of the synthesizer IC U1201. The filtered output from the ceramic filters is applied to the limiter input pin of the IF IC (pin 14).

The IF IC contains a quadrature detector using a ceramic phase-shift element (Y1102) to provide audio detection. Internal amplification provides an audio output level of 120 mV rms (at 60% deviation) from U1103 pin8 (AUDIOOUT) which is fed to the ASFIC_CMP (U0221) pin 2 (part of the Controller circuitry).

A received signal strength indicator (RSSI) signal is available at U1103 pin 5, having a dynamic range of 70 dB. The RSSI signal is interpreted by the microprocessor (U0101 pin 63) and in addition is available at accessory connector J0501-15.

2.6 “Extender” (Noise Blanker)

The 10.7 MHz output from the first mixer, which is present at the input of first IF amp Q1101, is also routed to the input of the “Extender” (noise blanker) circuitry and amplified by FET Q1610. The high input impedance of the FET stage minimizes loading of the signal in the receiver path. The output of Q1610 is further amplified by U1601, which is a wide-bandwidth, high gain differential amplifier (used in a single-ended configuration) incorporating an AGC gain control input. This gain block provides linear amplification of the instantaneous amplitude of the 10.7 MHz signal at the first mixer output. The output of U1601 is coupled to biased-detector Q1603. The bias is set so that noise impulses of a sufficient amplitude cause Q1603 to conduct. The following stages (Q1604 through Q1606) provide additional gain and pulse shaping which slows the turn-on and turn-off waveform applied to IF blanker switches Q1102 and Q1103. The result is that, for each noise impulse, the IF signal is smoothly ramped off and then on again, preventing the pulse from reaching the narrow IF selectivity, where ringing would cause an objectionable spike at the detector of a much longer duration than the original impulse.

If the repetition rate of noise impulses is so rapid that the noise blanker can no longer blank them individually, as indicated by a large increase in high-frequency content at the output of Q1604, stage Q1607 amplifies this level and turns on level detector Q1609. Its output is highly filtered into a DC voltage level which is proportional to the repetition rate of the noise impulses, and this is applied to the AGC input pin 5 of U1601, reducing its gain and therefore the amount of noise pulses which are detected and processed.

3.0 Low Band Transmitter Power Amplifier (PA) 25-60 W

The radio's 60 W PA is a three-stage amplifier used to amplify the output from the VCO to the radio transmit level. The line-up consists of three stages which utilize LDMOS technology. The first stage is pre-driver (U1401) that is controlled by pin 4 of PCIC (U1503) via Q1504 and Q1505 (CNTLVLTG). It is followed by driver stage Q1401, and final stage utilizing two devices (Q1402 and Q1403) connected in parallel. Q1402 and Q1403 are in direct contact with the heat sink.

To prevent damage to the final stage devices, a safety switch has been installed to prevent the transmitter from being keyed with the cover removed.

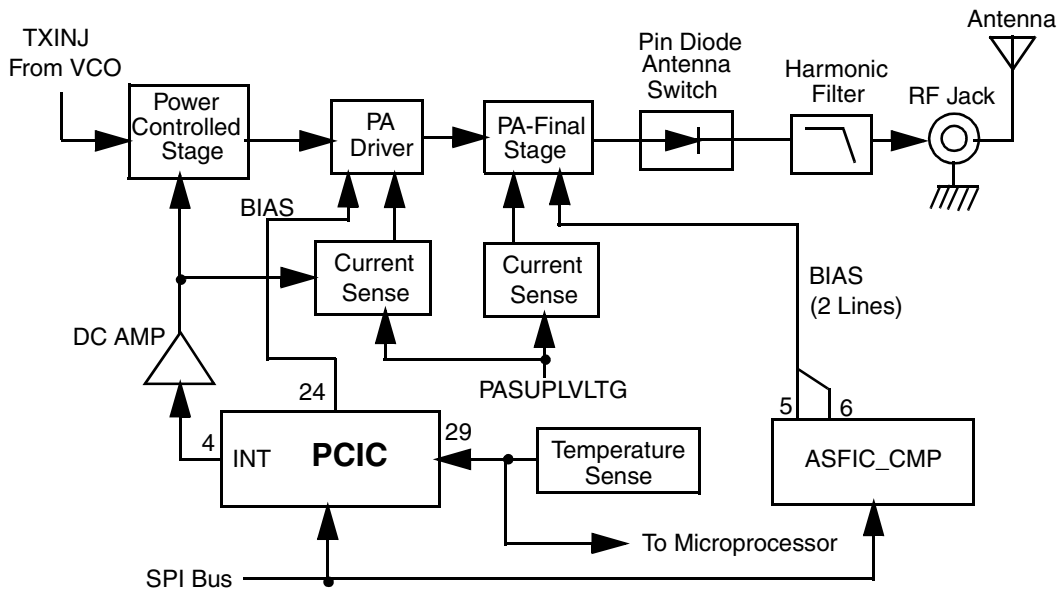

Figure 2-2 LowBand Transmitter Block Diagram

3.1 Power Controlled Stage

The first stage (U1401) is a 20dB gain integrated circuit containing two LDMOS FET amplifier stages. It amplifies the RF signal from the VCO (TXINJ). The output power of stage U1401 is controlled by a DC voltage applied to pin 1 from the power control circuit (U1503 pin 4, with transistors Q1504-5 providing current gain and level-shifting). The control voltage simultaneously varies the bias of two FET stages within U1401. This biasing point determines the overall gain of U1401 and therefore its output drive level to Q1401, which in turn controls the output power of the PA.

3.2 Driver Stage

The next stage is an LDMOS device (Q1401) providing a gain of 13dB. This device requires a positive gate bias and a quiescent current flow for proper operation. The voltage of the line MOSBIAS_1 is set during transmit mode by the PCIC pin 24, and fed to the gate of Q1401 via resistors R1402, R1447, R1449, R1458, R1459 and R1463. The bias voltage is tuned in the factory.

The circuitry associated with U1402-2 and Q1404 limits the variation in the output power of the driver stage resulting from changes in the input impedance of the final stage due to changes at the

antenna of the radio. The variation in the driver's output power is limited by controlling its DC current. The driver's DC current is monitored by measuring the voltage drop across current-sense resistors R1473-6, and this voltage is compared to a reference voltage on pin 6 of U1402-2. If the current through the sense resistors decreases, the circuit increases the bias voltage on the gate of Q1401 via Q1404. If the current increases, then the bias voltage decreases in order to keep the driver's current constant. Since the current must increase with increasing control voltage, an input path is provided to U1402-2 pin 5 from control line VCNTRL to enable this.

3.3 Final Stage

The final stage uses two LDMOS FET devices operating in parallel. Each device has its own adjustable gate bias voltage, MOSBIAS_2 and MOSBIAS_3, obtained from D/A outputs of the ASFIC. These bias voltages are also factory-tuned. If these transistors are replaced, the bias voltage must be tuned using the Tuner Software. Care must be taken not to damage the device by exceeding the maximum allowed bias voltage. The device's drain current is drawn directly from the radio's DC supply voltage input, PASUPVLTG, via current-measurement resistor R1409.

A matching network combines the output of the two devices and provides a 50-ohm source for the antenna switch and harmonic filter.

3.4 Antenna Switch

The antenna switch is operated by the 9T1 voltage source which forward biases diodes D1401 and D1402 during transmit, causing them to appear as a low impedance. D1401 allows the RF output from final stages Q1402 and Q1403 to be applied to the input of the low-pass harmonic filter (L1421-3 and associated components). D1402 appears as a short circuit at the input of the receiver (RXINJ), preventing transmitter RF power from entering the receiver. L1420 and C1456 appear as a broadband λ -wave transmission line, making the short circuit presented by D1402 appear as open circuit at the junction of D1401 and the harmonic filter input.

During receive mode, the 9T1 voltage is not present, and D1401 and D1402 do not conduct and appear as open circuits. This allows signals from the antenna jack to pass to the receiver input, and disconnects the transmitter final stages from this path.

3.5 Harmonic Filter

Components L1421-L1423 and C1449-C1455 form a seven-pole elliptic low-pass filter to attenuate harmonic energy of the transmitter to specifications level. R1411 is used to drain electrostatic charge that might otherwise build up on the antenna. The harmonic filter also prevents high level RF signals above the receiver passband from reaching the receiver circuits, improving spurious response rejection.

3.6 Power Control

The transmitter uses the Power Control IC (PCIC, U1503) to control the power output of the radio. A differential DC amplifier U1502-1 compares the voltage drop across current-measuring resistor R1409, which is proportional to the transmitter final stage DC current, with the voltage drop across resistor R1508 and R1535, which is proportional to the current through transistor Q1503. This transistor is controlled by the output of the differential amplifier, which varies the transistor Q1503. This transistor is controlled by the output of the differential amplifier, which varies the transistor

current until equilibrium of the two compared voltages is reached. The current through Q1503 develops a voltage across R1513 which is exactly proportional to the DC current of the final stages. This voltage is applied to the RF IN port of the PCIC (pin 1).

The PCIC has internal digital to analog converters (DACs) which provide a reference voltage of the control loop. The reference voltage level is programmable through the SPI line of the PCIC. This reference voltage is proportional to the desired power setting of the transmitter, and is factory programmed at several points across the frequency range of the transmitter to offset frequency response variations of the transmitter's power detector circuitry.

The PCIC provides a DC output voltage at pin 4 (INT) which is amplified and shifted in DC level by stages Q1504 and Q1505. The 0 to 4 volt DC range at pin 4 of U1503 is translated to a 0 to 8 volt DC range at the output of Q1505, and applied as VCNTL to the power-adjust input pin of the first transmitter stage U1401. This adjusts the transmitter power output to the intended value. Variations in antenna impedance cause variations in the DC current of the final stages, and the PCIC adjusts the control voltage above or below its nominal value to reduce power if current drain increases, or raise power if current drain decreases.

Capacitors C1503-4 and C1525, in conjunction with resistors and integrators within the PCIC, control the transmitter power-rise (key-up) and power-decay (de-key) characteristic to minimize splatter into adjacent channels.

U1501 is a temperature-sensing device which monitors the circuit board temperature in the vicinity of the transmitter circuits and provides a dc voltage to the PCIC (TEMP, pin 29) proportional to temperature. If the DC voltage produced exceeds the set threshold in the PCIC, the transmitter output power will be reduced so as to reduce the transmitter temperature.

3.7 TX Safety Switch

The TX Safety Switch consists of S1501, Q1506, and diode pairs D1502 and D1503 providing protection to the Pnal stage devices Q1402 and Q1403. These Pnal stage devices can be degraded or destroyed if the radio is keyed without the cover in place due to the lack of a good thermal path to the chassis.

Switch S1501 is closed when the radio's cover is screwed in place by means of the carbonized region on the cover's pressure pad making contact with the Pnger plating on the radio's PCB. With the cover in place, transistor Q1506 is off, back-biasing diodes D1502 and D1503, enabling proper transmitter operation. When the cover is not in place, S1501 opens, causing Q1506 to turn on, pulling the cathodes of D1502 and D1503 to ground, resulting in the shorting of the transmitter's bias lines and control voltage.

4.0 Low Band Frequency Synthesis

The frequency synthesizer subsystem consists of the reference oscillator crystal (Y1201), the Low Voltage Fractional-N synthesizer (LVFRAC-N, U1201), and the receive and transmit VCOs and buffers (Q1303 through Q1308 and associated components).

4.1 Fractional-N Synthesizer

The LVFRAC-N synthesizer IC (U1201) consists of a reference oscillator, pre-scaler, a programmable loop divider, control divider logic, a phase detector, a charge pump, an A/D converter

for low frequency digital modulation, a balance attenuator to balance the high frequency analog modulation and low frequency digital modulation, a 13V positive voltage multiplier, a serial interface for control, and finally a super filter for the regulated 9.3 volt supply.

Regulated 9.3 volts DC applied to the super filter input (U1201 pin 30) delivers a very low noise output voltage of 8.3 volts DC (VSF) at pin 28. External device Q1201 allows greater current sourcing capability. The VSF source supplies the receive and transmit VCOs and first buffer stages. The synthesizer IC supply voltage is provided by a dedicated 5V regulator (U1250) to minimize power supply noise.

In order to generate a high voltage to supply the phase detector (charge pump) output stage at pin VCP (U1201 pin 47), a capacitive voltage multiplier circuit (CR1202 and C1209) generates a voltage of 13 volts DC. This multiplier is driven by two 1.05 MHz clock signals from U1201 pins 15 and 14 (VMULT1 and VMULT2) which are 180° out of phase.

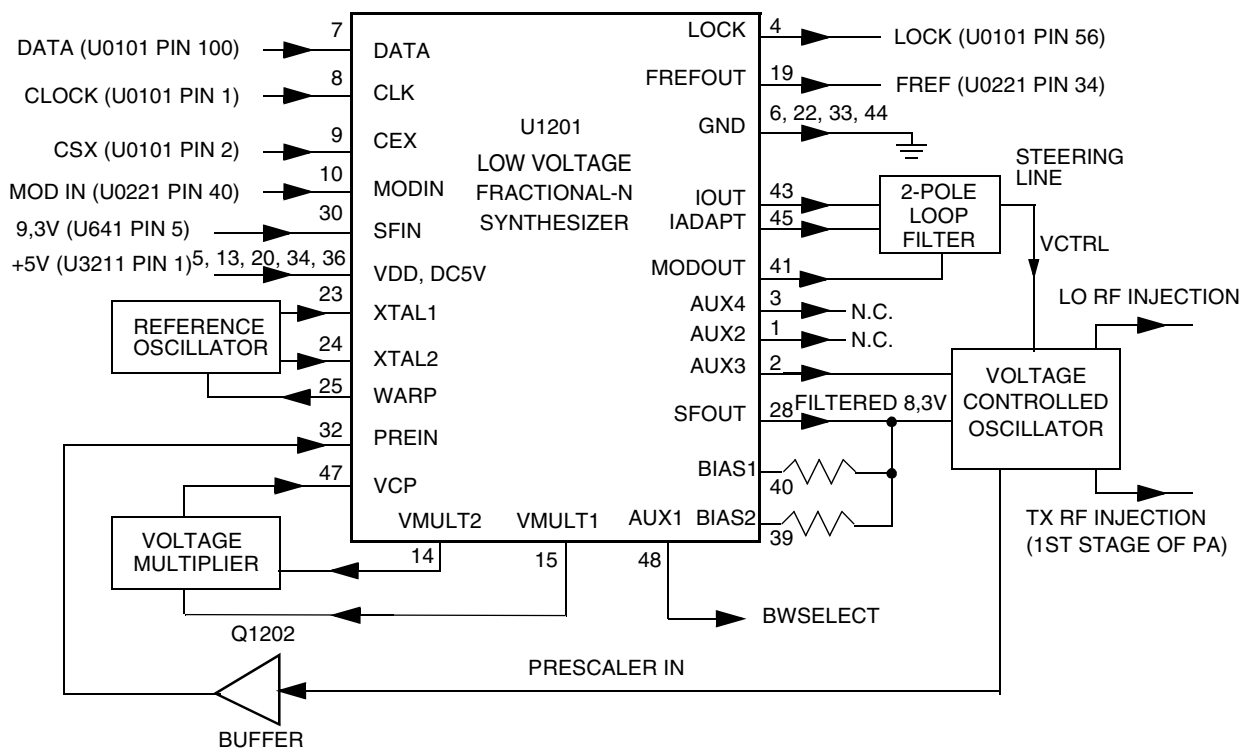

Figure 2-3 LowBand Synthesizer Block Diagram

Output LOCK (U1201-4) provides information about the lock status of the synthesizer loop. A high level at this output indicates a stable loop. A buffered output of the 16.8 MHz reference frequency is provided at pin 19.

The operating frequency of the synthesizer is loaded serially from the microprocessor via the data line (DATA, U1201-7), clock line (CLK, U1201-8) and chip select line (CSX, U1201-9). The reference oscillator circuit within U1201 uses an external 16.8 MHz crystal (Y1201). Varactor CR1201 allows software-controlled frequency adjustment (warp) and temperature compensation of the oscillator frequency. Warp adjustment is performed using serial data from the microprocessor. This controls the setting of an A/D converter, with its output (WARP, pin 25) applied to CR1201.

4.2 Voltage Controlled Oscillator (VCO)

Separate VCO and buffer circuits are used for receiver injection and transmitter carrier frequency generation. Since the receiver uses high-side injection, the receiver VCO frequency range is 10.7 MHz above the transmit VCO range. The VCO/buffers are bandsplit into three ranges depending on radio model, covering radio operating frequencies of 29.7 to 36.0 MHz, 36.0 to 42.0 MHz, or 42.0 to 50.0 MHz. The corresponding three frequency ranges for the receive VCO are 40.4 to 46.7 MHz, 46.7 to 52.7 MHz, and 52.7 to 60.7 MHz.

The VCOs, together with Fractional-N synthesizer U1201, generate the required frequencies for transmit and receive mode. The TRB line (U1201 pin 2) determines which VCO/buffer circuit is to be enabled. A high level on TRB will turn on the transistors in U1378 to turn on via R1376, applying the 8.3 volt VSF source to the receiver VCO and first buffer. The second buffer in each string operates from the 9V3 source and become active when RF is applied to their inputs.

The RF signal at the bases of the second buffers are combined and fed back to the Fractional-N synthesizer via PRE_IN where it is compared to the reference frequency as described below in "Synthesizer Operation". The Fractional-N IC provides a DC steering voltage VCTRL to adjust and maintain the VCO at the correct frequency.

With a steering voltage from 2.5V to 11V at the appropriate varactor diode (CR1302 for the RX VCO, or CR1310 for the TX VCO), the full VCO tuning range is obtained. Each VCO uses an AGC circuit to maintain a constant VCO output level across the frequency band. A diode (CR1306 in the receive VCO, or CR1314 in the transmit VCO) is configured as a voltage doubler which rectifies the RF level sampled at the VCO drain and applies a proportional negative DC voltage to the VCO gate. Increased RF level reduces the VCO gain to compensate.

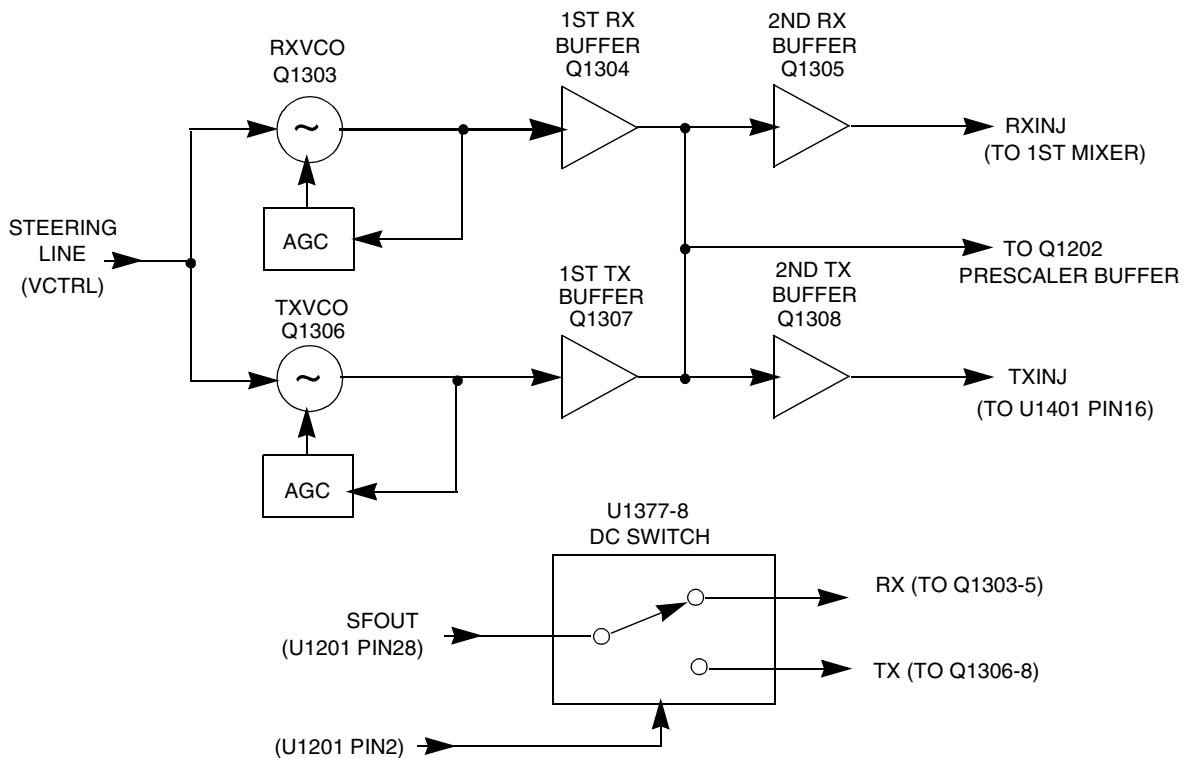

Figure 2-4 LowBand VCO/Buffer Block Diagram

The VCO output is taken from the source and applied to the first buffer transistor (Q1304 receive, Q1307 transmit). The first buffer output is further amplified by the second buffer transistor (Q1305 Rx, Q1308 Tx) before being applied to the receiver first mixer or transmitter first stage input. In TX mode the modulation signal coming from the LVFRAC-N synthesizer IC (MODOUT, U1201 pin 41) is superimposed on the DC steering line voltage by capacitive divider C1215, C1208 and C1212, causing modulation of the TX VCO using the same varactor as used for frequency control.

4.3 Synthesizer Operation

The complete synthesizer subsystem comprises mainly of low voltage LVFRAC-N synthesizer IC, Reference Oscillator (crystal oscillator with temperature compensation), charge pump circuitry, loop filter circuitry, and voltage-controlled oscillators and buffers. A sample of the VCO operating signal PRE_IN is amplified by feedback buffer Q1202, low-pass filtered by L1205, C1222 and C1224, and fed to U1201 pin 32 (PREIN).

The pre-scaler in the synthesizer (U1201) is basically a dual modulus pre-scaler with selectable divider ratios. This divider ratio of the pre-scaler is controlled by the loop divider, which in turn receives its inputs via the serial interface to the microprocessor. The output of the pre-scaler is applied to the loop divider. The output of the loop divider is connected to the phase detector, which compares the loop divider's output signal with the reference signal. The reference signal is generated by dividing down the signal of the reference oscillator, whose frequency is controlled by Y1201.

The output signal of the phase detector is a pulsed DC signal which is routed to the charge pump. The charge pump outputs a current at pin 43 of U1201 (I OUT). The loop filter (which consists of R1205-6, R1208, C1212-14) transforms this current into a voltage that is applied to the varactor diodes (CR1310 for transmit, CR1302 for receive) and alters the output frequency of the appropriate VCO. The current can be set to a value fixed in the LVFRAC-N IC or to a value determined by the currents flowing into BIAS 1 (U1201-40) or BIAS 2 (U1201-39). The currents are set by the value of R1211 or R1207 respectively. The selection of the three different bias sources is done by software programming.

To reduce synthesizer lock time when new frequency data has been loaded into the synthesizer the magnitude of the loop current is increased by enabling the IADAPT (U1201-45) for a certain software programmable time (Adapt Mode). The adapt mode timer is started by a low to high transient of the CSX line. When the synthesizer is within the lock range the current is determined only by the resistors connected to BIAS 1, BIAS 2, or the internal current source. A settled synthesizer loop is indicated by a high level of signal LOCK (U1201-4).

In order to modulate the PLL the two spot modulation method is utilized. Via pin 10 (MODIN) on U1201, the audio signal is applied to both the A/D converter (low frequency path) and the balanced attenuator (high frequency path). The A/D converter converts the low frequency analog modulating signal into a digital code that is applied to the loop divider, thereby causing the carrier to deviate. The balance attenuator is used to adjust the VCO's deviation sensitivity to high frequency modulating signals. The output of the balance attenuator is present at the MODOUT port (U1201-41) and superimposed on the VCO steering line voltage by a divider consisting of C1215, C1208 and C1212.

LOW BAND TROUBLESHOOTING CHARTS

1.0 Troubleshooting Flow Chart for Transmitter

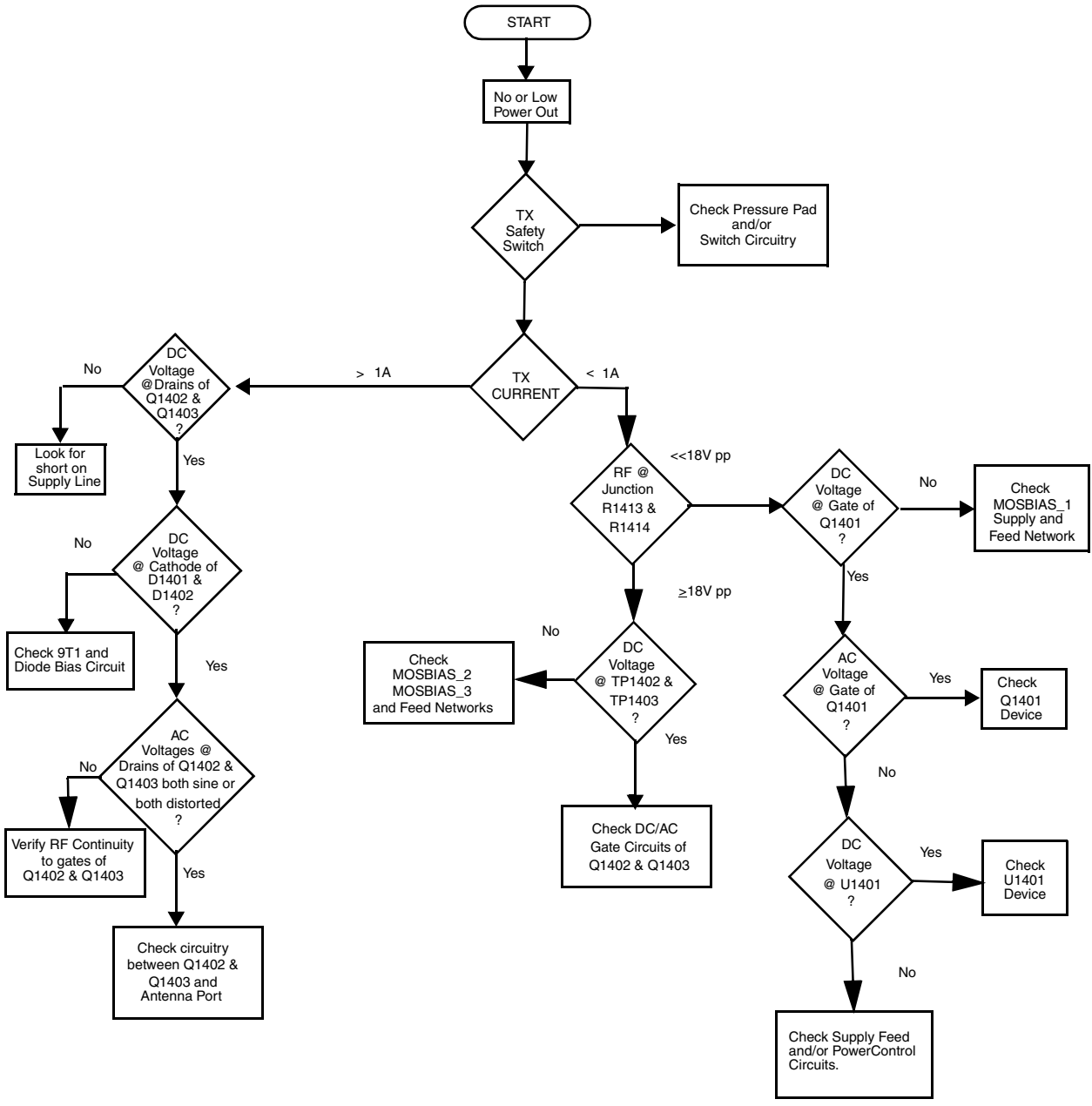

2.0 Troubleshooting Flow Chart for Receiver (Sheet 1 of 2)

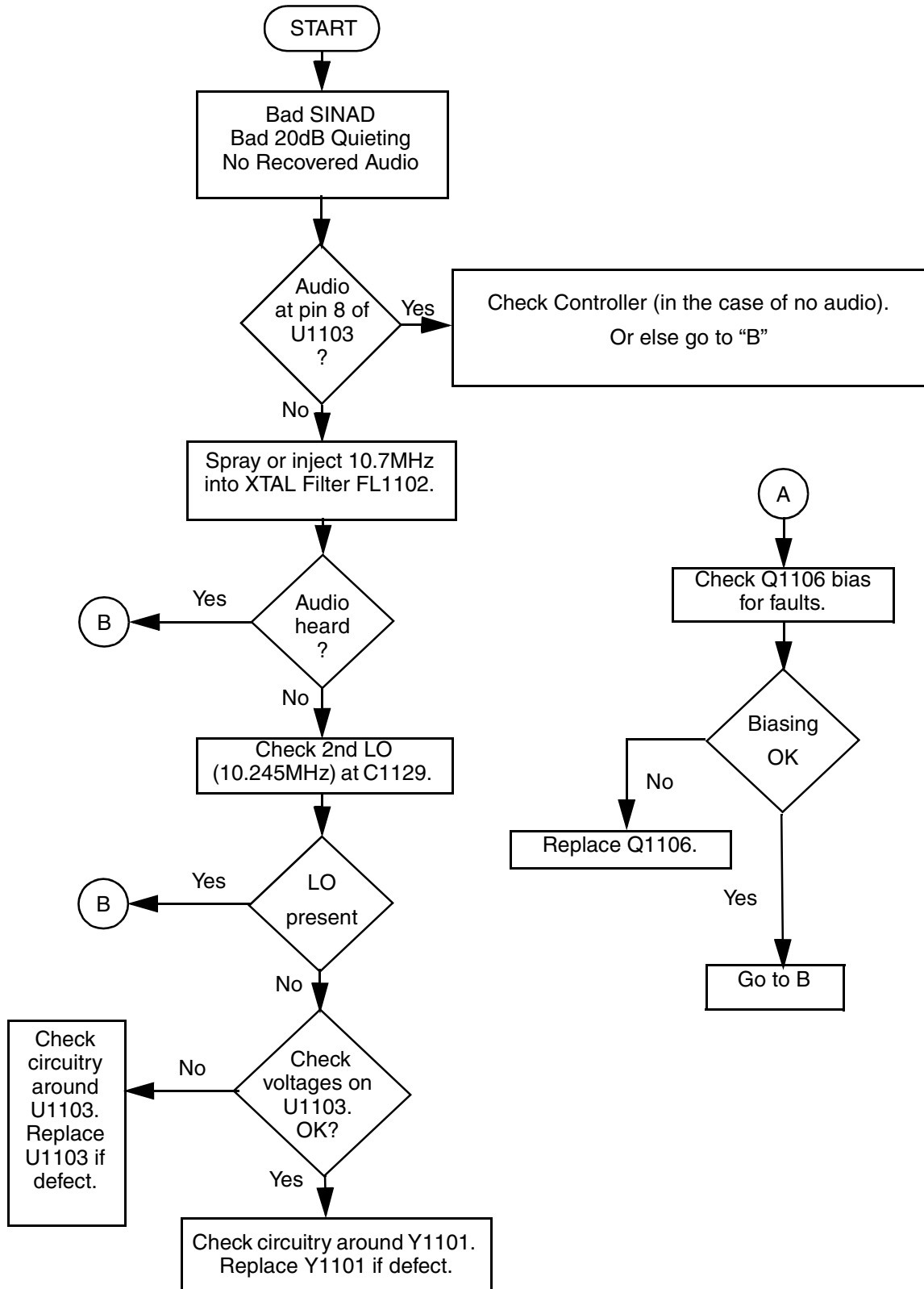

Troubleshooting Flow Chart for Receiver (Sheet 2 of 2)

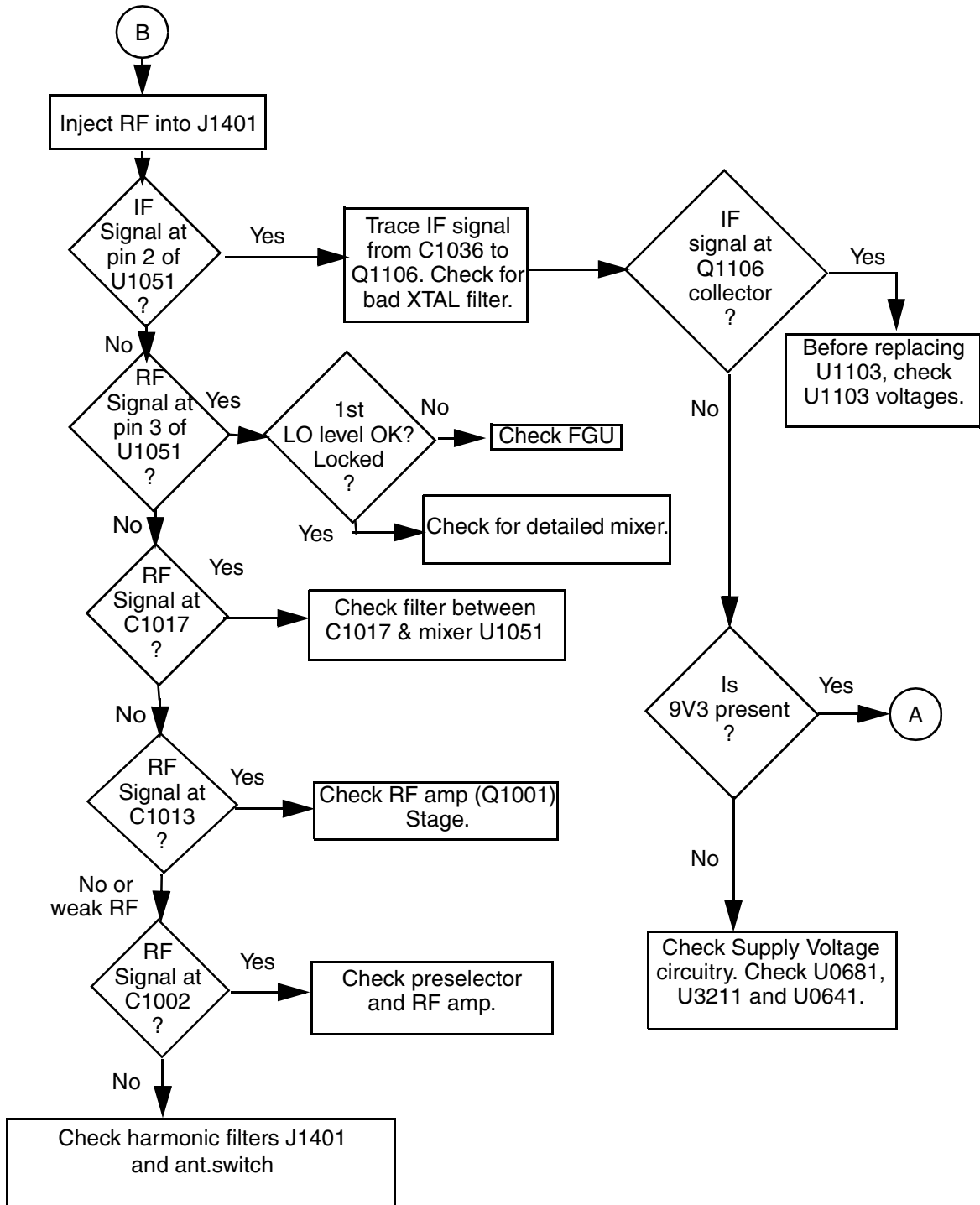

3.0 Troubleshooting Flow Chart for Synthesizer

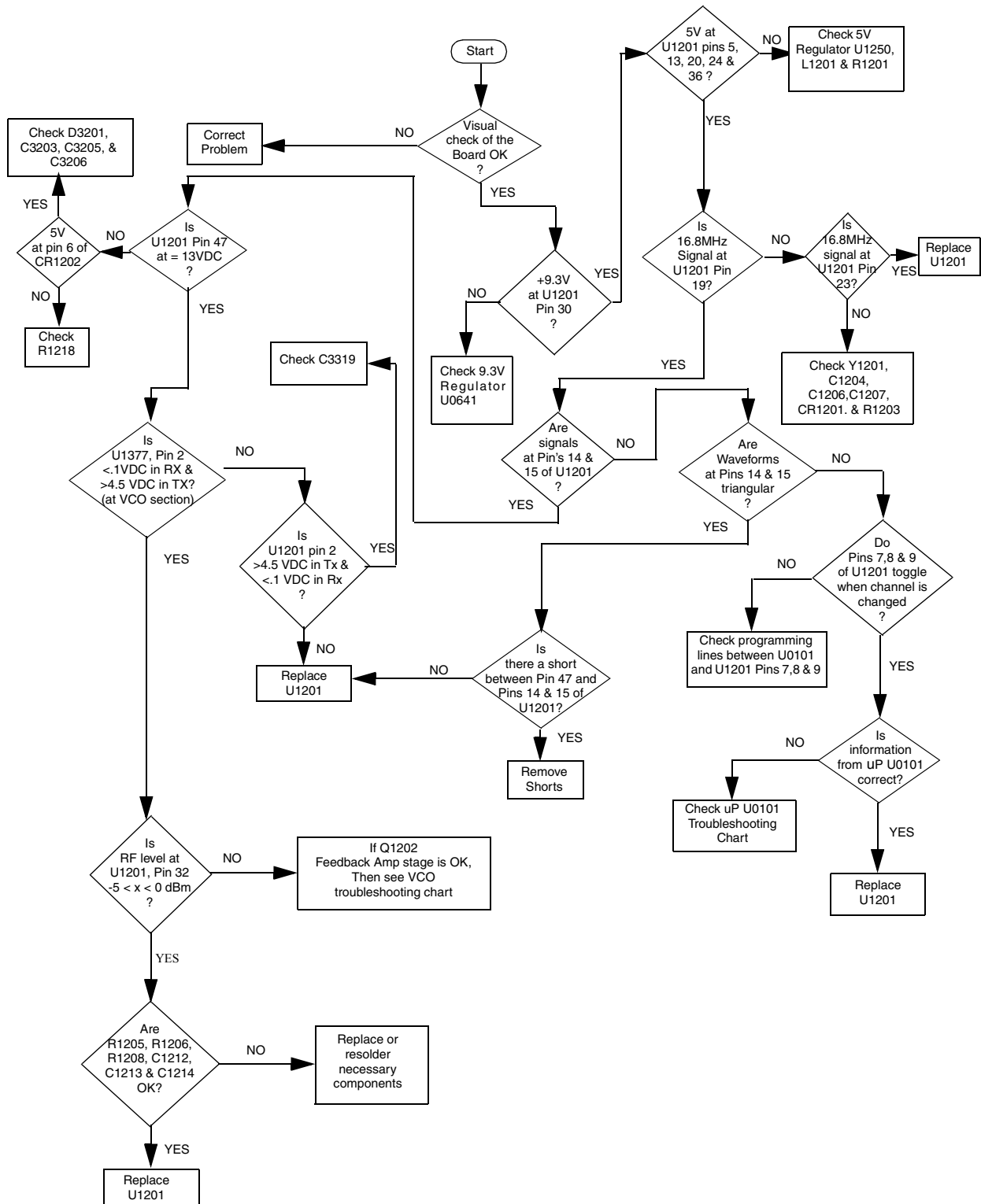

4.0 Troubleshooting Flow Chart for VCO

RX - VCO

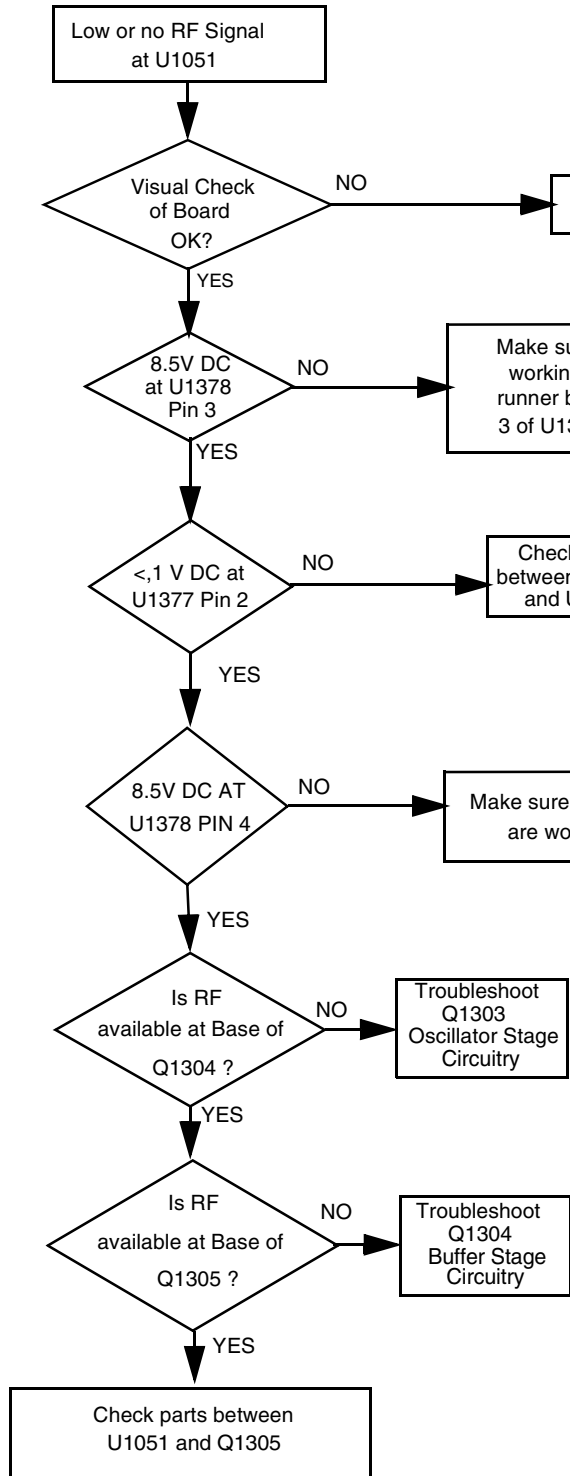

TX - VCO

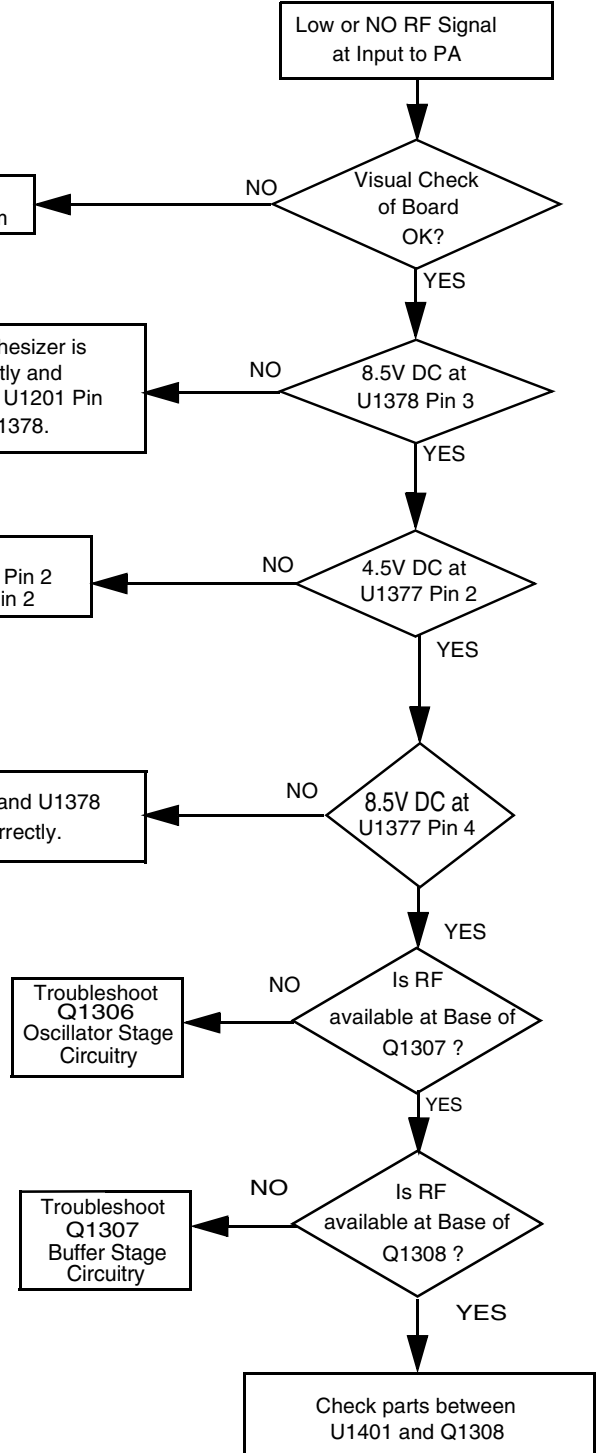

LOW BAND PCB/SCHEMATICS/PARTS LISTS

1.0 Allocation of Schematics and Circuit Boards

1.1 Controller Circuits

The Low Band circuits are contained on the printed circuit board (PCB) which also contains the Controller circuits. This Chapter shows the schematics for the Low Band circuits only, refer to the Controller section for details of the related Controller circuits . The PCB component layouts and the Parts Lists in this Chapter show both the Controller and Low Band circuit components. The Low Band schematics and the related PCB and parts list are shown in the tables below.

Table 4-1 LB1 25-60W Diagrams and Parts Lists

PCB :	
8486206B06 Main Board Top Side	Page 4-3
8486206B06 Main Board Bottom Side	Page 4-4
SCHEMATICS	
Power Amplifier 25-60W (Sheet 1 of 2)	Page 4-5
Power Amplifier 25-60W (Sheet 2 of 2)	Page 4-6
Voltage Controlled Oscillator	Page 4-7
Receiver Front End	Page 4-8
IF (Sheet 1 of 2)	Page 4-9
IF (Sheet 2 of 2)	Page 4-10
Noise Blanker	Page 4-11
FRACN	Page 4-12
Parts List	
8486206B06	Page 4-13
Controller version is T6	

Table 4-2 LB2 25-60W Diagrams and Parts Lists

PCB :	
8486207B05 Main Board Top Side	Page 4-16
8486207B05 Main Board Bottom Side	Page 4-17
SCHEMATICS	
Power Amplifier 25-60W (Sheet 1 of 2)	Page 4-18
Power Amplifier 25-60W (Sheet 2 of 2)	Page 4-19
Voltage Controlled Oscillator	Page 4-20
Receiver Front End	Page 4-21
IF (Sheet 1 of 2)	Page 4-22
IF (Sheet 2 of 2)	Page 4-23
Noise Blanker	Page 4-24
FRACN	Page 4-25
Parts List	
8486207B05	Page 4-26
Controller version is T6	

Table 4-3 LB3 25-60W Diagrams and Parts Lists

PCB :	
8485908z02 Main Board Top Side	Page 4-29
8485908z02 Main Board Bottom Side	Page 4-30
SCHEMATICS	
Power Amplifier 25-60W (Sheet 1 of 2)	Page 4-31
Power Amplifier 25-60W (Sheet 2 of 2)	Page 4-32
Voltage Controlled Oscillator	Page 4-33
Receiver Front End	Page 4-34
IF (Sheet 1 of 2)	Page 4-35
IF (Sheet 2 of 2)	Page 4-36
Noise Blanker	Page 4-37
FRACN	Page 4-38
Parts List	
8485908z02	Page 4-39
Controller version is T6	

2.0 LB Range1 25-60W PCB 8486206B06 / Schematics

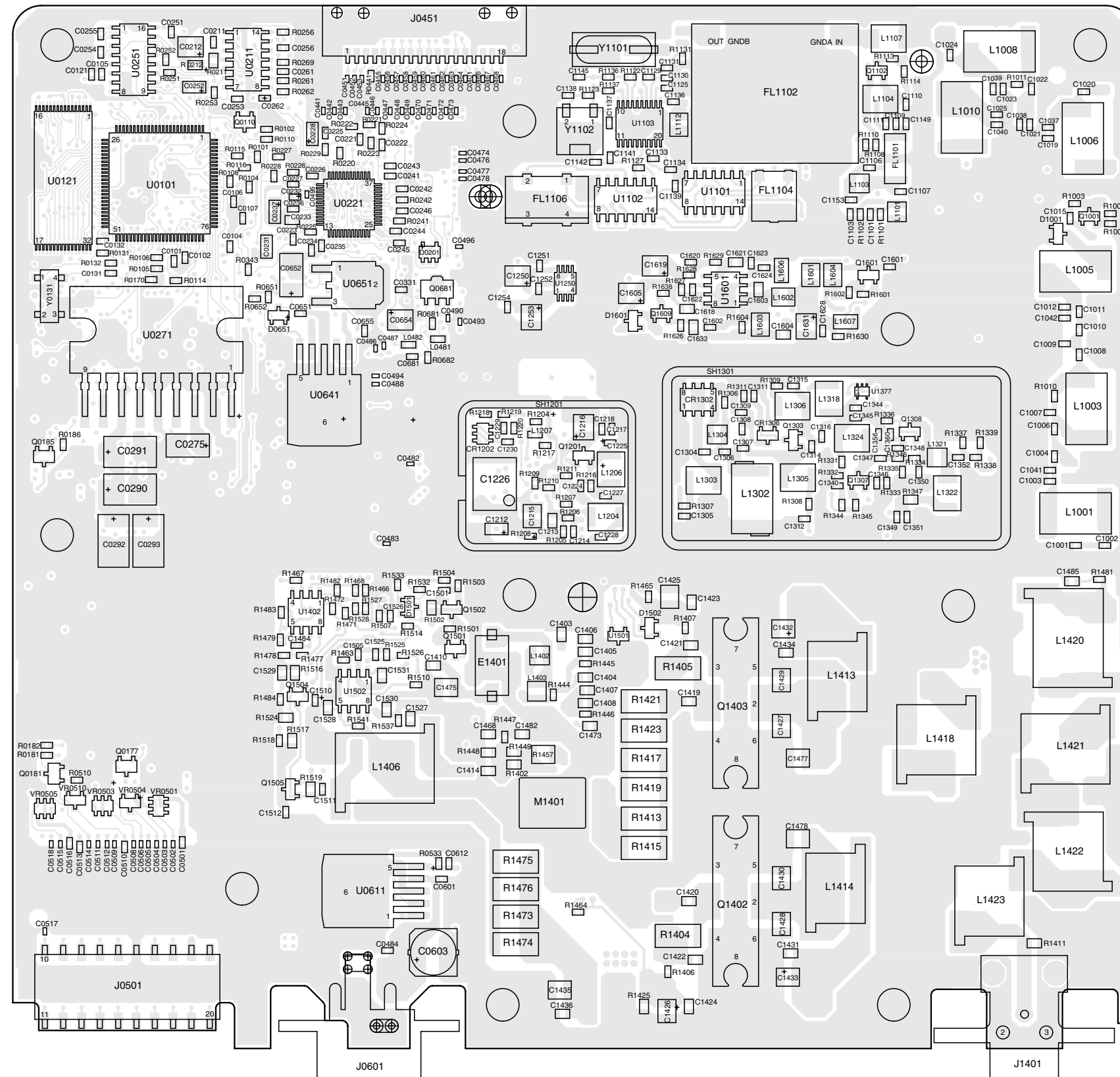

ZWG0130593-O
LB1 (29.7-36.0 MHz)
8486206B06 Top Side

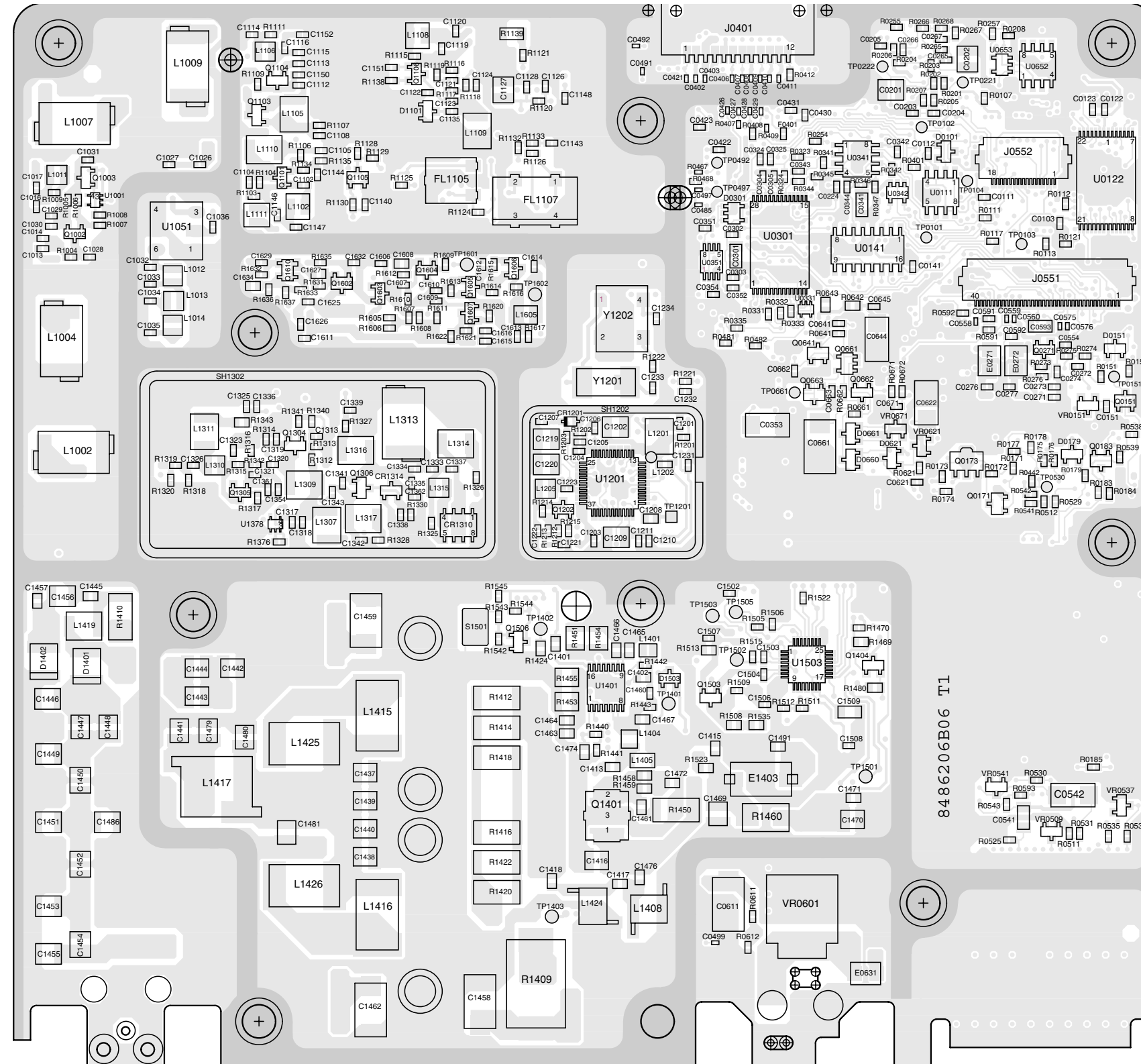

LB1 (29.7-36.0 MHz) 8486206B06 Bot Side

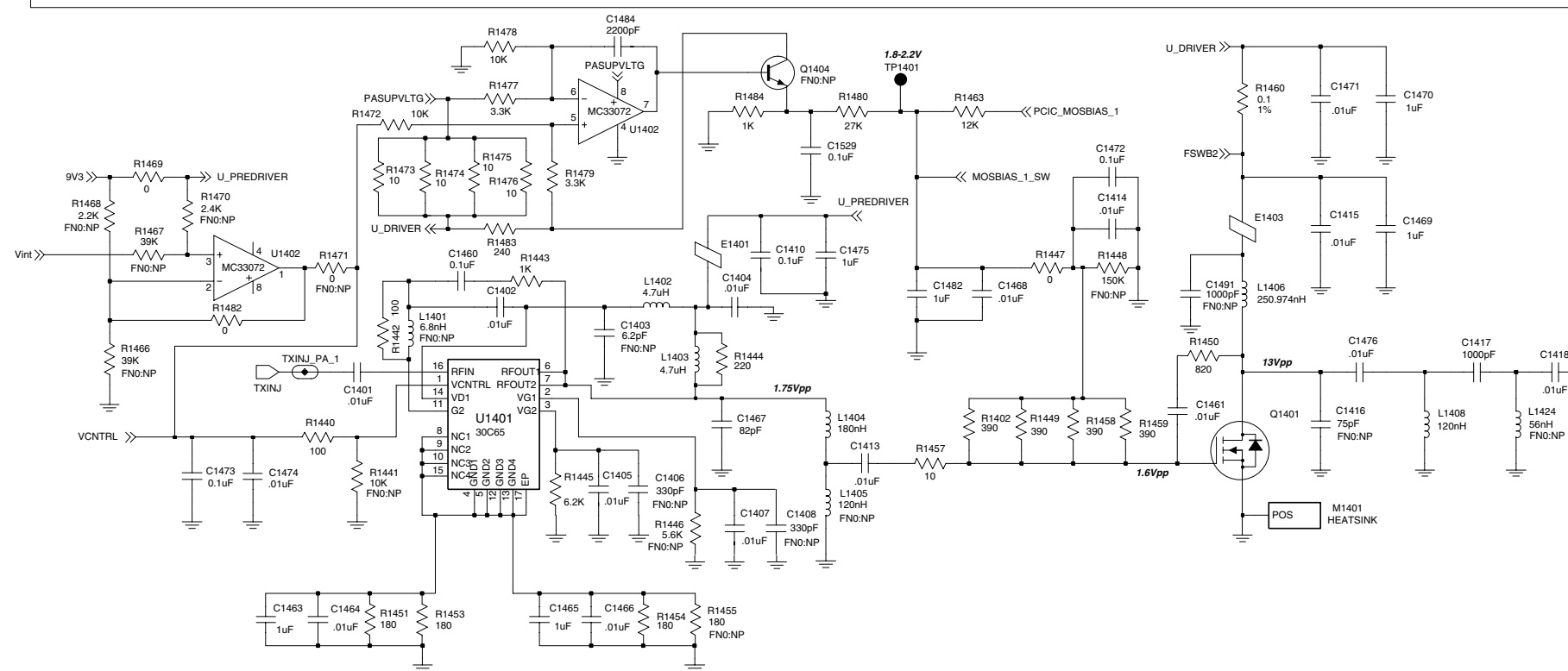
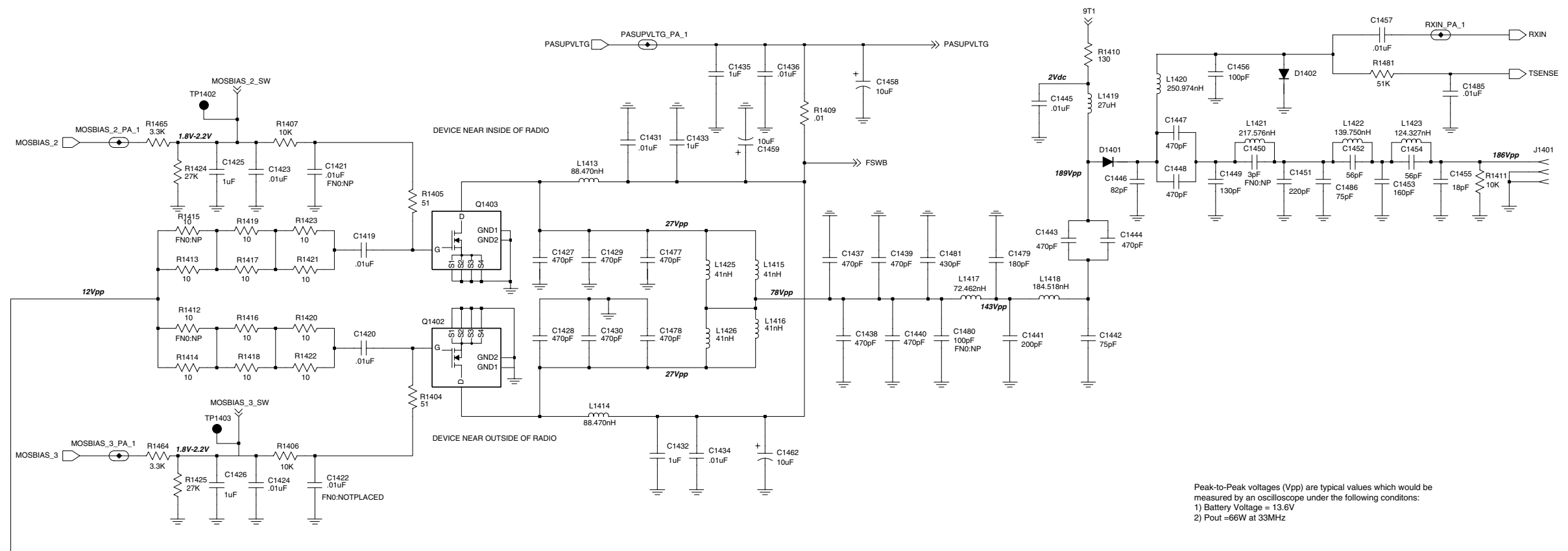

FL0830687-O

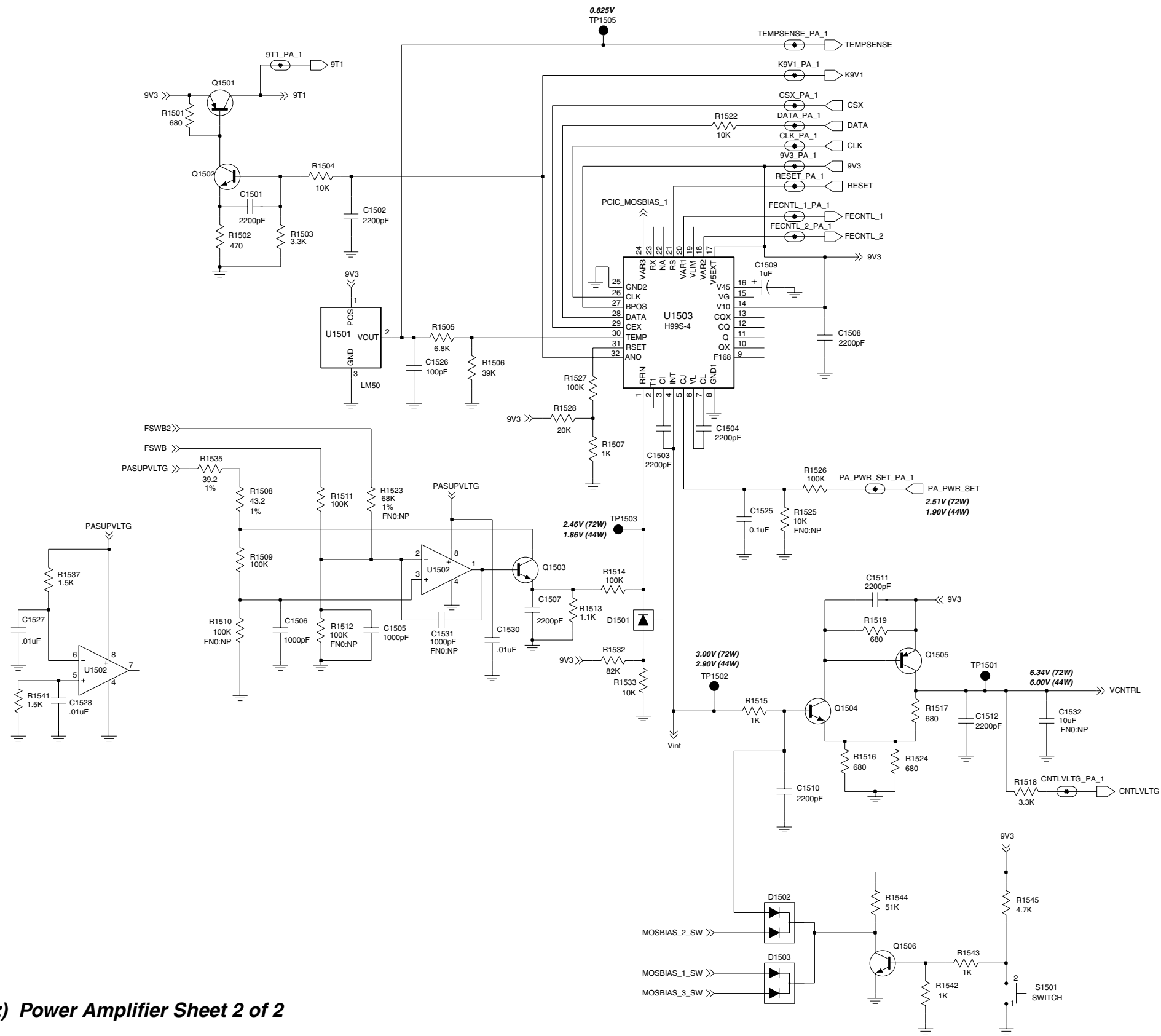

LB1 (29.7-36.0 MHz) Power Amplifier Sheet 2 of 2

FL0830688-O

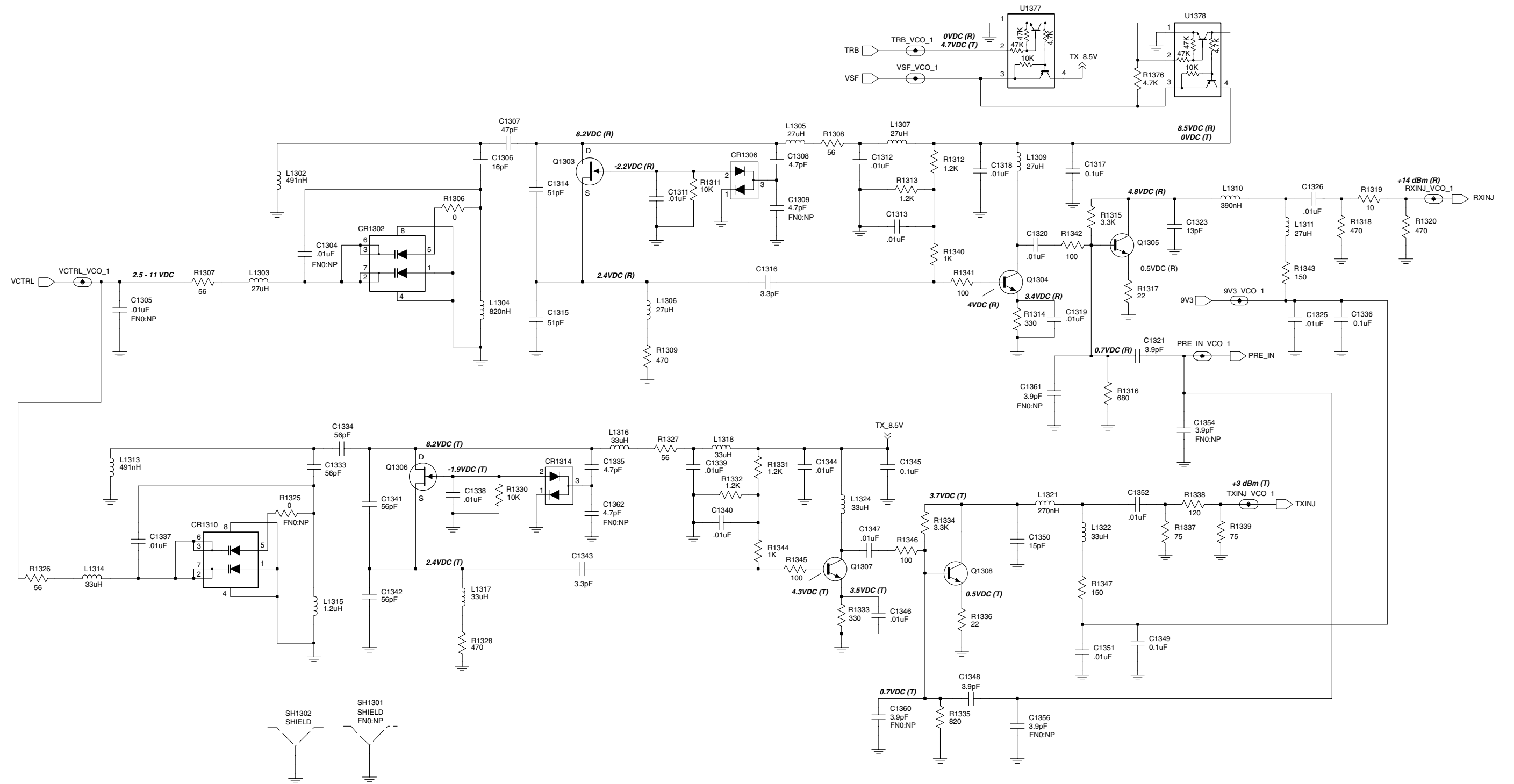

FL0830686-O

LB1 (29.7-36.0 MHz) Voltage Controlled Oscillator

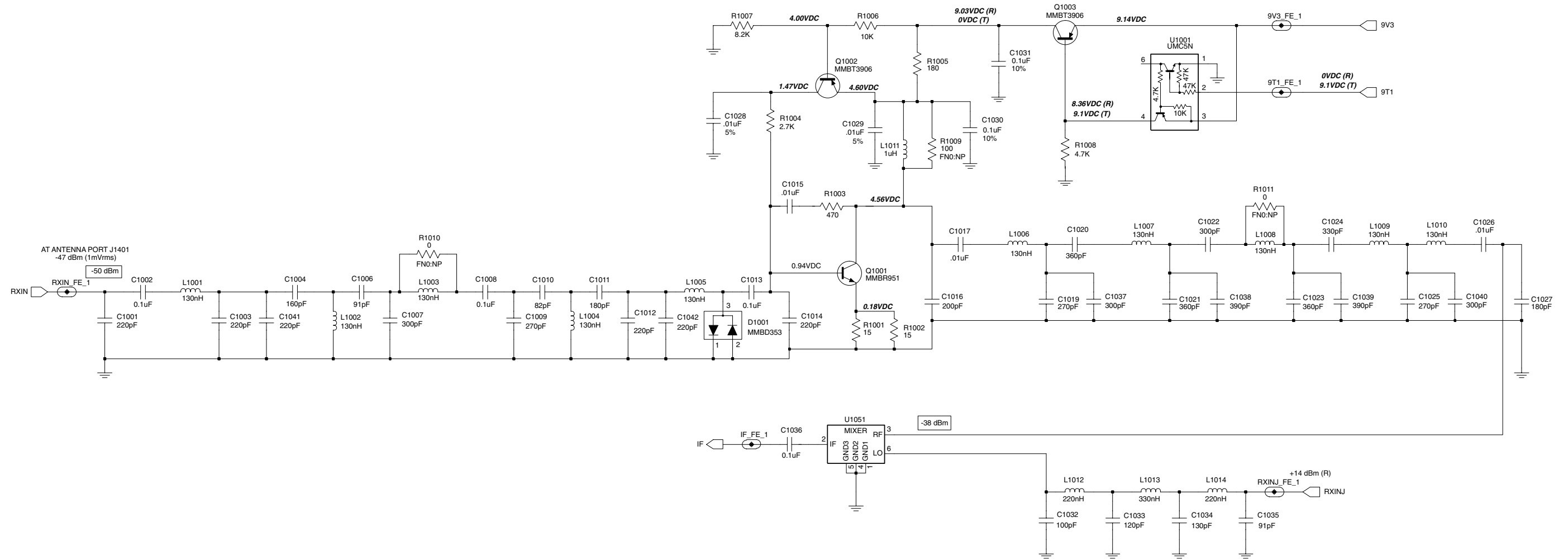

FL0830689-O

LB1 (29.7-36.0 MHz) Receiver Front End

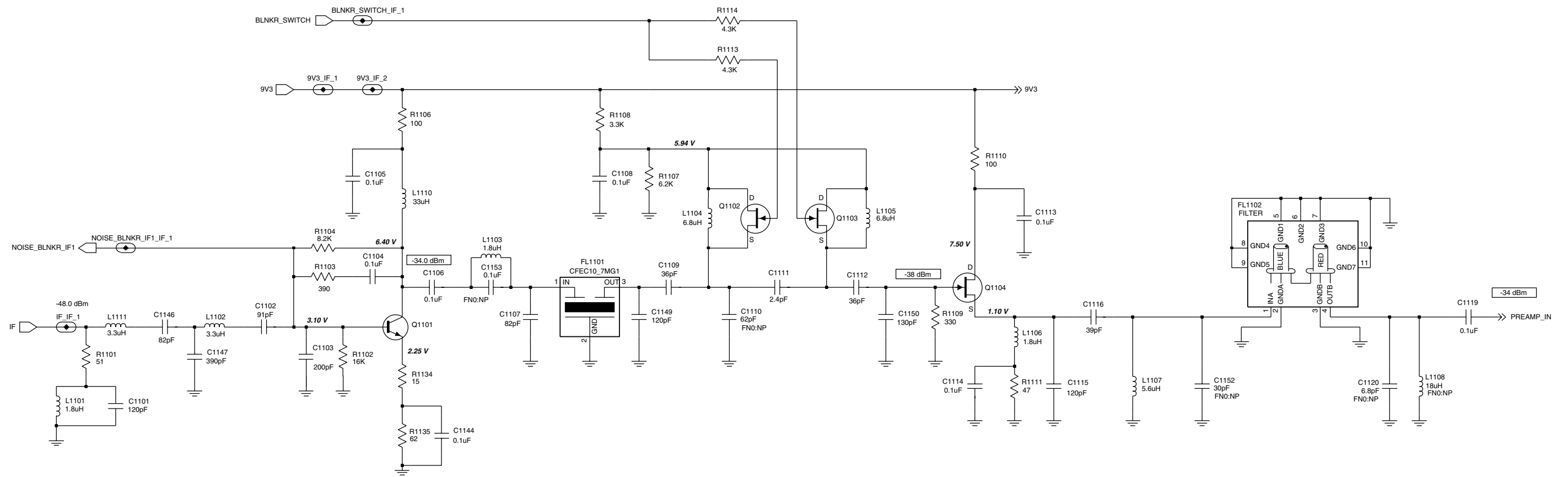

FL0830690-O

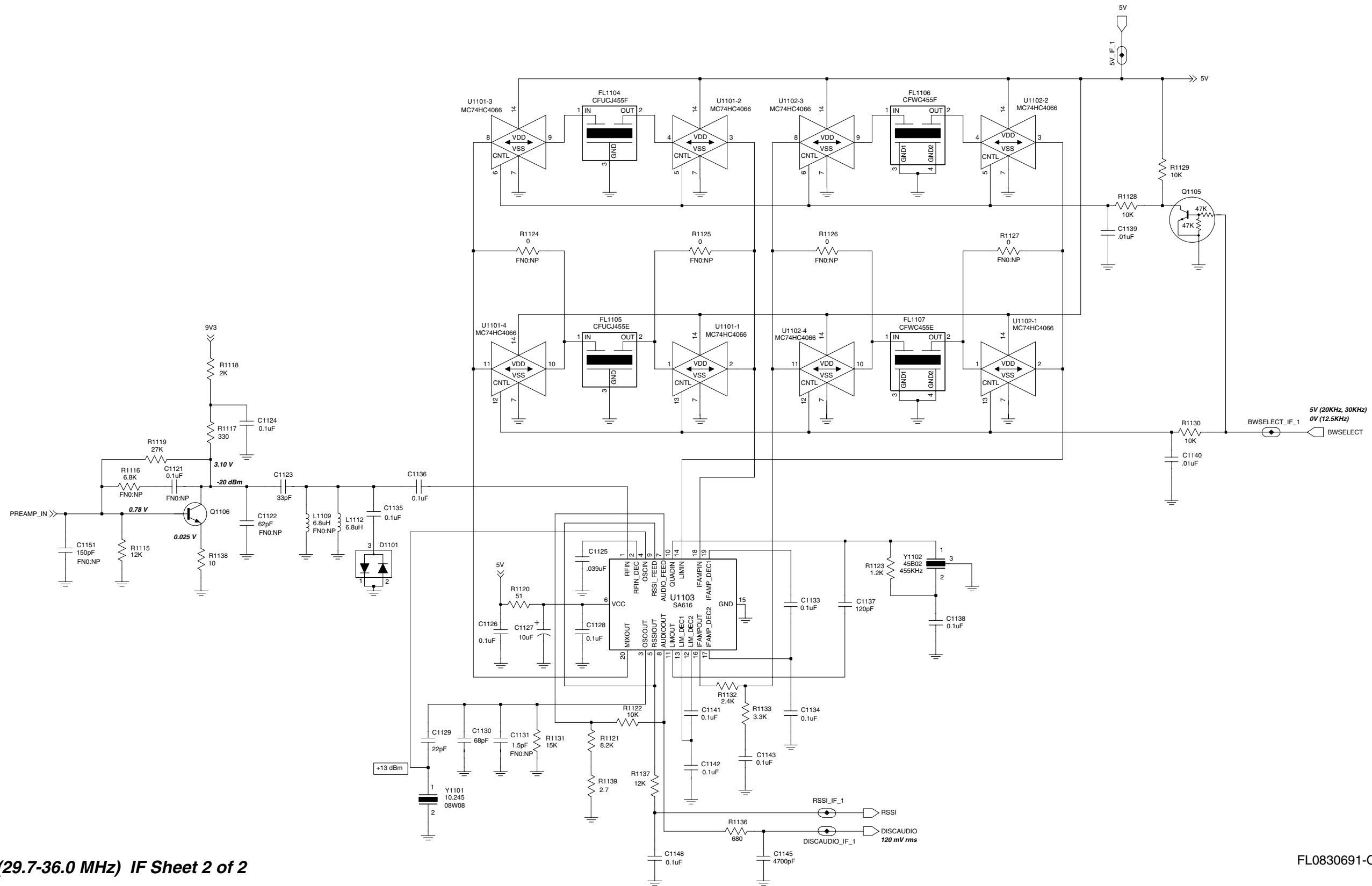

LB1 (29.7-36.0 MHz) IF Sheet 2 of 2

FL0830691-O

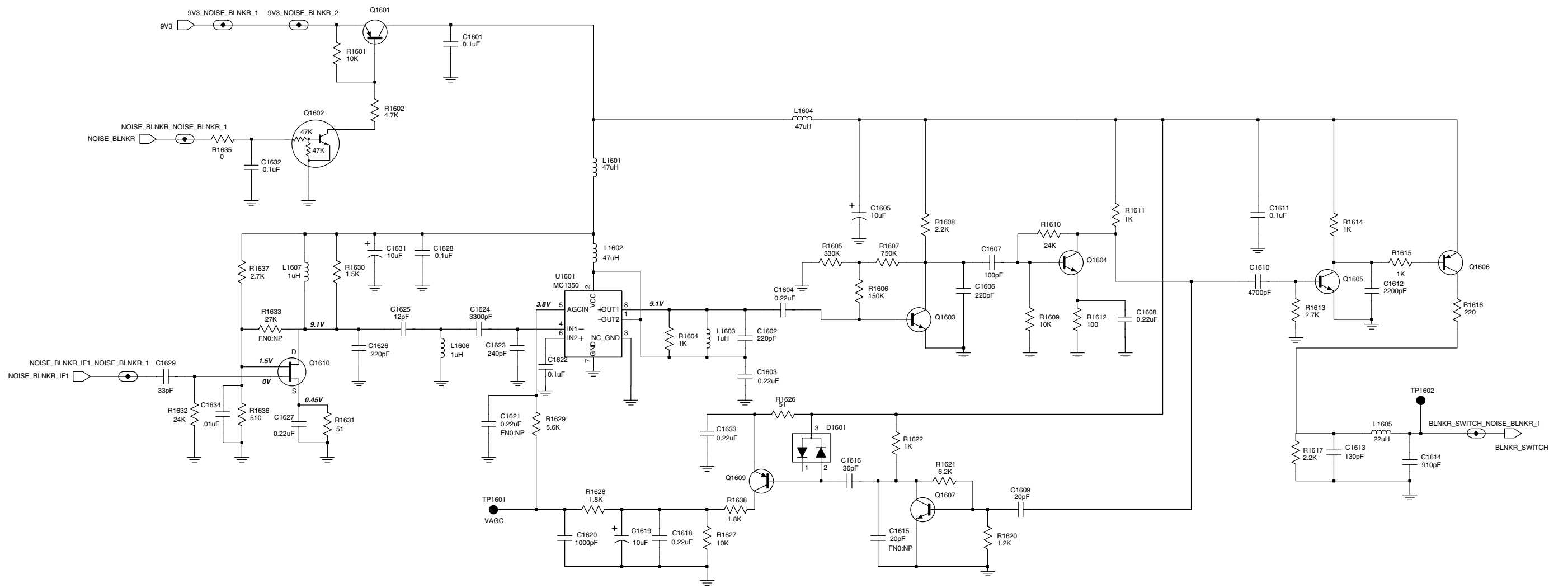

FL0830692-O

LB1 (29.7-36.0 MHz) Noise Blanker

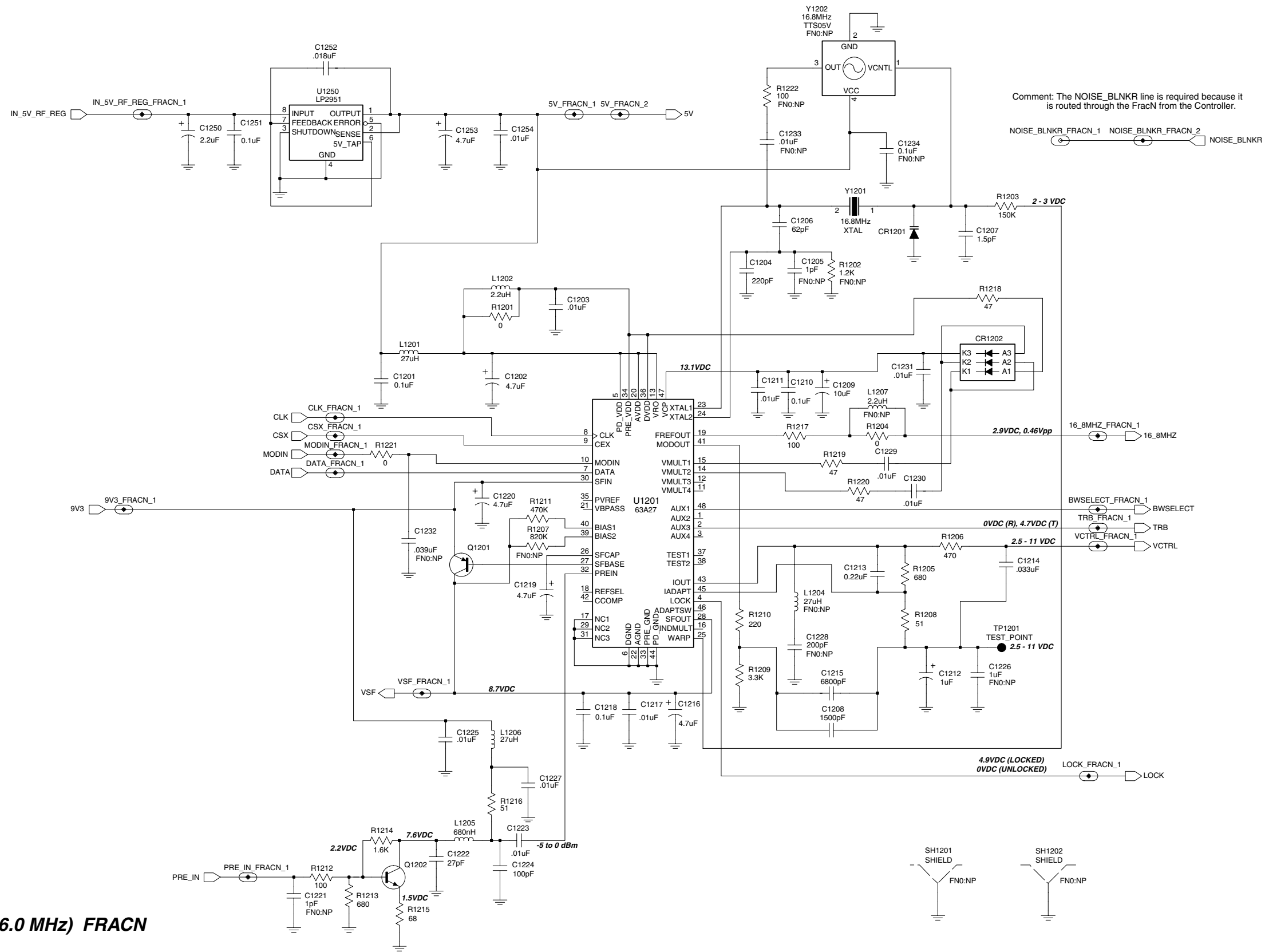

LB1 (29.7-36.0 MHz) FRACN

2.1 LB1 PCB 8486206B06 Parts List

Circuit Ref	Motorola Part No.	Description
C1001	2113740F59	220pF
C1002	2113743E20	0.1uF
C1003	2113740F59	220pF
C1004	2113740F56	160pF
C1006	2113740F50	91pF
C1007	2113740F62	300pF
C1008	2113743E20	0.1uF
C1009	2113740F61	270pF
C1010	2113740F49	82pF
C1011	2113740F57	180pF
C1012	2113740F59	220pF
C1013	2113743E20	0.1uF
C1014	2113740F59	220pF
C1015	2113741F49	.01uF
C1016	2113740F58	200pF
C1017	2113741F49	.01uF
C1019	2113740F61	270pF
C1020	2113740F64	360pF
C1021	2113740F64	360pF
C1022	2113740F62	300pF
C1023	2113740F64	360pF
C1024	2113740F63	330pF
C1025	2113740F61	270pF
C1026	2113741F49	.01uF
C1027	2113740F57	180pF
C1028	2113741F49	.01uF
C1029	2113741F49	.01uF
C1030	2113743E20	0.1uF
C1031	2113743E20	0.1uF
C1032	2113740F51	100pF
C1033	2113740F53	120pF
C1034	2113740F54	130pF
C1035	2113740F50	91pF
C1036	2113743E20	0.1uF
C1037	2113740F62	300pF
C1038	2113740F65	390pF
C1039	2113740F65	390pF
C1040	2113740F62	300pF
C1041	2113740F59	220pF
C1042	2113740F59	220pF
C1101	2113740F53	120pF
C1102	2113740F50	91pF
C1103	2113740F58	200pF
C1104	2113743E20	0.1uF
C1105	2113743E20	0.1uF
C1106	2113743E20	0.1uF
C1107	2113740F49	82pF
C1108	2113743E20	0.1uF
C1109	2113740F40	36pF
C1111	2113740L03	2.4pF
C1112	2113740F40	36pF
C1113	2113743E20	0.1uF
C1114	2113743E20	0.1uF
C1115	2113740F53	120pF
C1116	2113740F41	39pF

Circuit Ref	Motorola Part No.	Description
C1119	2113743E20	0.1uF
C1123	2113740F39	33pF
C1124	2113743E20	0.1uF
C1125	2113743E11	.039uF
C1126	2113743E20	0.1uF
C1127	2311049A57	10uF
C1128	2113743E20	0.1uF
C1129	2113740F35	22pF
C1130	2113740F47	68pF
C1133	2113743E20	0.1uF
C1134	2113743E20	0.1uF
C1135	2113743E20	0.1uF
C1136	2113743E20	0.1uF
C1137	2113740F53	120pF
C1138	2113743E20	0.1uF
C1139	2113741F49	.01uF
C1140	2113741F49	.01uF
C1141	2113743E20	0.1uF
C1142	2113743E20	0.1uF
C1143	2113743E20	0.1uF
C1144	2113743E20	0.1uF
C1145	2113741F41	4700pF
C1146	2113740F49	82pF
C1147	2113740F65	390pF
C1148	2113743E20	0.1uF
C1149	2113740F53	120pF
C1150	2113740F54	130pF
C1201	2113743E20	0.1uF
C1202	2311049J11	4.7uF
C1203	2113741F49	.01uF
C1204	2113740F59	220pF
C1206	2113740L37	62pF
C1207	2113740F07	1.5pF
C1208	2113740A82	1500pF
C1209	2311049A57	10uF
C1210	2113743E20	0.1uF
C1211	2113741F49	.01uF
C1212	2311049A07	1uF
C1213	2113743A23	0.22uF
C1214	2113743E10	.033uF
C1215	2113740C37	6800pF
C1216	2311049J11	4.7uF
C1217	2113741F49	.01uF
C1218	2113743E20	0.1uF
C1219	2311049J11	4.7uF
C1220	2311049J11	4.7uF
C1222	2113740F37	27pF
C1223	2113741F49	.01uF
C1224	2113740F51	100pF
C1225	2113741F49	.01uF
C1227	2113741F49	.01uF
C1229	2113741F49	.01uF
C1230	2113741F49	.01uF
C1231	2113741F49	.01uF
C1250	2311049A09	2.2uF
C1251	2113743E20	0.1uF

Circuit Ref	Motorola Part No.	Description
C1252	2113743E05	.018uF
C1253	2311049J11	4.7uF
C1254	2113741F49	.01uF
C1306	2113740L23	16pF
C1307	2113740L34	47pF
C1308	2113740F19	4.7pF
C1311	2113741F49	.01uF
C1312	2113741F49	.01uF
C1313	2113741F49	.01uF
C1314	2113740L35	51pF
C1315	2113740L35	51pF
C1316	2113740F15	3.3pF
C1317	2113743E20	0.1uF
C1318	2113741F49	.01uF
C1319	2113741F49	.01uF
C1320	2113741F49	.01uF
C1321	2113740F17	3.9pF
C1323	2113740L21	13pF
C1325	2113741F49	.01uF
C1326	2113741F49	.01uF
C1333	2113740L36	56pF
C1334	2113740L36	56pF
C1335	2113740F19	4.7pF
C1336	2113743E20	0.1uF
C1337	2113741F49	.01uF
C1338	2113741F49	.01uF
C1339	2113741F49	.01uF
C1340	2113741F49	.01uF
C1341	2113740L36	56pF
C1342	2113740L36	56pF
C1343	2113740F15	3.3pF
C1344	2113741F49	.01uF
C1345	2113743E20	0.1uF
C1346	2113741F49	.01uF
C1347	2113741F49	.01uF
C1348	2113740F17	3.9pF
C1349	2113743E20	0.1uF
C1350	2113740F31	15pF
C1351	2113741F49	.01uF
C1352	2113741F49	.01uF
C1401	2113741A45	.01uF
C1402	2113741A45	.01uF
C1404	2113741A45	.01uF
C1405	2113741A45	.01uF
C1407	2113741A45	.01uF
C1410	2113741M69	0.1uF
C1413	2113741A45	.01uF
C1414	2113741A45	.01uF
C1415	2113741A45	.01uF
C1417	2113740A79	1000pF
C1418	2113741A45	.01uF
C1419	2113741A45	.01uF
C1420	2113741A45	.01uF
C1423	2113741A45	.01uF
C1424	2113741A45	.01uF
C1425	2113741W01	1uF

Circuit Ref	Motorola Part No.	Description
C1426	2113741W01	1uF
C1427	2111078B59	470pF
C1428	2111078B59	470pF
C1429	2111078B59	470pF
C1430	2111078B59	470pF
C1431	2113741A45	.01uF
C1432	2113741W01	1uF
C1433	2113741W01	1uF
C1434	2113741A45	.01uF
C1435	2113741W01	1uF
C1436	2113741A45	.01uF
C1437	2111078B59	470pF
C1438	2111078B59	470pF
C1439	2111078B59	470pF
C1440	2111078B59	470pF
C1441	2111078B50	200pF
C1442	2111078B39	75pF
C1443	2111078B59	470pF
C1444	2111078B59	470pF
C1445	2113741A45	.01uF
C1446	2180060M41	82pF
C1447	2111078B59	470pF
C1448	2111078B59	470pF
C1449	2180060M46	130pF
C1451	2180060M51	220pF
C1452	2180060M37	56pF
C1453	2180060M48	160pF
C1454	2180060M37	56pF
C1455	2180060M25	18pF
C1456	2180060M43	100pF
C1457	2113741A45	.01uF
C1458	2311049C01	10uF
C1459	2311049C01	10uF
C1460	2113743E20	0.1uF
C1461	2113741A45	.01uF
C1462	2311049C01	10uF
C1463	2113928E01	1uF
C1464	2113741A45	.01uF
C1465	2113928E01	1uF
C1466	2113741A45	.01uF
C1467	2113740A53	82pF
C1468	2113741A45	.01uF
C1469	2113741W01	1uF
C1470	2113741W01	1uF
C1471	2113741A45	.01uF
C1472	2113741M69	0.1uF
C1473	2113741M69	0.1uF
C1474	2113741A45	.01uF
C1475	2113741W01	1uF
C1476	2113741A45	.01uF
C1477	2111078B59	470pF
C1478	2111078B59	470pF
C1479	2111078B49	180pF
C1481	2111078B58	430pF
C1482	2113928E01	1uF
C1484	2113741F33	2200pF

Circuit Ref	Motorola Part No.	Description
C1485	2113741A45	.01uF
C1486	2180060M40	75pF
C1501	2113741F33	2200pF
C1502	2113741F33	2200pF
C1503	2113741F33	2200pF
C1504	2113741F33	2200pF
C1505	2113741F25	1000pF
C1506	2113741F25	1000pF
C1507	2113741F33	2200pF
C1508	2113741F33	2200pF
C1509	2311049A07	1uF
C1510	2113741F33	2200pF
C1511	2113741F33	2200pF
C1512	2113741F33	2200pF
C1525	2113743E20	0.1uF
C1526	2113740F51	100pF
C1527	2113741A45	.01uF
C1528	2113741A45	.01uF
C1529	2113741M69	0.1uF
C1530	2113741A45	.01uF
C1601	2113743E20	0.1uF
C1602	2113740F59	220pF
C1603	2113743A23	0.22uF
C1604	2113743A23	0.22uF
C1605	2311049A57	10uF
C1606	2113740F59	220pF
C1607	2113740F51	100pF
C1608	2113743A23	0.22uF
C1609	2113740F34	20pF
C1610	2113741F41	4700pF
C1611	2113743E20	0.1uF
C1612	2113741F33	2200pF
C1613	2113740F54	130pF
C1614	2113741F24	910pF
C1616	2113740F40	36pF
C1618	2113743A23	0.22uF
C1619	2311049A57	10uF
C1620	2113741F25	1000pF
C1622	2113743E20	0.1uF
C1623	2113740F60	240pF
C1624	2113741F37	3300pF
C1625	2113740F29	12pF
C1626	2113740F59	220pF
C1627	2113743A23	0.22uF
C1628	2113743E20	0.1uF
C1629	2113740F39	33pF
C1631	2311049A57	10uF
C1632	2113743E20	0.1uF
C1633	2113743A23	0.22uF
C1634	2113741A45	.01uF
CR1201	4802245J22	1T363
CR1202	4802233J09	IMN10
CR1302	4805649Q14	HN1V02H
CR1306	4880154K03	MMBD353
CR1310	4805649Q14	HN1V02H
CR1314	4880154K03	MMBD353

Circuit Ref	Motorola Part No.	Description
D1001	4880154K03	MMBD353
D1101	4880154K03	MMBD353
D1401	4808379X02	MA4P1450
D1402	4808379X02	MA4P1450
D1501	4880236E05	MMBD301
D1502	4813833C02	MMBD6100
D1503	4813833C02	MMBD6100
D1601	4880154K03	MMBD353
E1401	2408380X02	FERRITE BEAD
E1403	2408380X02	FERRITE BEAD
FL1101	9180656U03	CFEC10_7MG1
FL1102	9180022M09	CRYSTAL FILTER, 10.7 MHZ
FL1104	9180468V04	CFUCJ455F
FL1105	9180468V05	CFUCJ455E
FL1106	9180469V04	CFWC455F
FL1107	9180469V05	CFWC455E
J1401	0986166B02	MINI-U ANTENNA CONN
L1001	2408382A11	130nH
L1002	2408382C11	130nH
L1003	2408382A11	130nH
L1004	2408382C11	130nH
L1005	2408382A11	130nH
L1006	2408382A11	130nH
L1007	2408382C11	130nH
L1008	2408382A11	130nH
L1009	2408382C11	130nH
L1010	2408382A11	130nH
L1011	2462587N68	1uH
L1012	2462587N57	220nH
L1013	2462587N59	330nH
L1014	2462587N57	220nH
L1101	2462587N33	1.8uH
L1102	2408383X07	3.3uH
L1103	2462587N33	1.8uH
L1104	2480289M10	6.8uH
L1105	2480289M10	6.8uH
L1106	2462587N33	1.8uH
L1107	2480289M09	5.6uH
L1110	2480289M18	33uH
L1111	2408383X07	3.3uH
L1112	2483411T35	6.8uH
L1201	2480289M17	27uH
L1202	2462587Q20	2.2uH
L1205	2462587N64	680nH
L1206	2480289M17	27uH
L1302	2408382D19	491nH
L1303	2480289M17	27uH
L1304	2462587N66	820nH
L1305	2480289M17	27uH
L1306	2480289M17	27uH
L1307	2480289M17	27uH
L1309	2480289M17	27uH
L1310	2462587N60	390nH
L1311	2480289M17	27uH
L1313	2408382D19	491nH
L1314	2480289M18	33uH

Circuit Ref	Motorola Part No.	Description
L1315	2462587N69	1.2uH
L1316	2480289M18	33uH
L1317	2480289M18	33uH
L1318	2480289M18	33uH
L1321	2462587N58	270nH
L1322	2480289M18	33uH
L1324	2480289M18	33uH
L1402	2462587U09	4.7uH
L1403	2462587U09	4.7uH
L1404	2462587X56	180nH
L1406	2408381X36	250.974nH
L1408	2408384A10	120nH
L1413	2408381X17	88.470nH
L1414	2408381X17	88.470nH
L1415	2485873L04	41nH
L1416	2485873L04	41nH
L1417	2408381X14	72.462nH
L1418	2408381X30	184.518nH
L1419	2480289M17	27uH
L1420	2408381X36	250.974nH
L1421	2408381X33	217.576nH
L1422	2408381X26	139.750nH
L1423	2408381X23	124.327nH
L1425	2485873L04	41nH
L1426	2485873L04	41nH
L1601	2483411T45	47uH
L1602	2483411T45	47uH
L1603	2483411T73	1uH
L1604	2483411T45	47uH
L1605	2483411T41	22uH
L1606	2462587T30	1uH
L1607	2462587T30	1uH
M1401	2686201B01	HEATSINK
Q1001	4880173R01	MMBR951
Q1002	4813824A17	MMBT3906
Q1003	4813824A17	MMBT3906
Q1101	4813827A07	MMBR941
Q1102	4813823A05	MMBFU310L
Q1103	4813823A05	MMBFU310L
Q1104	4813823A05	MMBFU310L
Q1105	4880048M01	DTC144EKA
Q1106	4813827A07	MMBR941
Q1201	4813824A17	MMBT3906
Q1202	4880173R01	MMBR951
Q1303	4884235R02	MMBFU310
Q1304	4880173R01	MMBR951
Q1305	4880173R01	MMBR951
Q1306	4884235R02	MMBFU310
Q1307	4880173R01	MMBR951
Q1308	4880173R01	MMBR951
Q1401	4886212B01	MRF1518
Q1402	4886136B01	MRF1550
Q1403	4886136B01	MRF1550
Q1501	4880141L03	BCW68G
Q1502	4813824A10	MMBT3904
Q1503	4813824A10	MMBT3904

Circuit Ref	Motorola Part No.	Description
Q1504	4813824A10	MMBT3904
Q1505	4813824A17	MMBT3906
Q1506	4813824A10	MMBT3904
Q1601	4813824A17	MMBT3906
Q1602	4880048M01	DTC144EKA
Q1603	4813824A10	MMBT3904
Q1604	4813824A10	MMBT3904
Q1605	4813824A10	MMBT3904
Q1606	4813824A17	MMBT3906
Q1607	4813824A10	MMBT3904
Q1609	4813824A17	MMBT3906
Q1610	4805585Q17	NE25139
R1001	0662057A05	15
R1002	0662057A05	15
R1003	0662057A41	470
R1004	0662057A59	2.7K
R1005	0662057A31	180
R1006	0662057A73	10K
R1007	0662057A71	8.2K
R1008	0662057A65	4.7K
R1101	0662057A18	51
R1102	0662057A78	16K
R1103	0662057A39	390
R1104	0662057A71	8.2K
R1106	0662057A25	100
R1107	0662057A68	6.2K
R1108	0662057A61	3.3K
R1109	0662057A37	330
R1110	0662057A25	100
R1111	0662057A17	47
R1113	0662057A64	4.3K
R1114	0662057A64	4.3K
R1115	0662057A75	12K
R1117	0662057A37	330
R1118	0662057A56	2K
R1119	0662057A83	27K
R1120	0662057A18	51
R1121	0662057A71	8.2K
R1122	0662057A73	10K
R1123	0662057A51	1.2K
R1128	0662057A73	10K
R1129	0662057A73	10K
R1130	0662057A73	10K
R1131	0662057A77	15K
R1132	0662057A58	2.4K
R1133	0662057A61	3.3K
R1134	0662057A05	15
R1135	0662057A20	62
R1136	0662057A45	680
R1137	0662057A75	12K
R1138	0662057A01	10
R1139	0611077A12	2.7
R1201	0662057B47	0
R1203	0662057B02	150K
R1204	0662057B47	0
R1205	0662057A45	680

Circuit Ref	Motorola Part No.	Description
R1206	0662057A41	470
R1208	0662057A18	51
R1209	0662057A61	3.3K
R1210	0662057A33	220
R1211	0662057B14	470K
R1212	0662057A25	100
R1213	0662057A45	680
R1214	0662057A54	1.6K
R1215	0662057A21	68
R1216	0662057A18	51
R1217	0662057A25	100
R1218	0662057A17	47
R1219	0662057A17	47
R1220	0662057A17	47
R1221	0662057B47	0
R1306	0662057B47	0
R1307	0662057A19	56
R1308	0662057A19	56
R1309	0662057A41	470
R1311	0662057A73	10K
R1312	0662057A51	1.2K
R1313	0662057A51	1.2K
R1314	0662057A37	330
R1315	0662057A61	3.3K
R1316	0662057A45	680
R1317	0662057A09	22
R1318	0662057A41	470
R1319	0662057A01	10
R1320	0662057A41	470
R1326	0662057A19	56
R1327	0662057A19	56
R1328	0662057A41	470
R1330	0662057A73	10K
R1331	0662057A51	1.2K
R1332	0662057A51	1.2K
R1333	0662057A37	330
R1334	0662057A61	3.3K
R1335	0662057A47	820
R1336	0662057A09	22
R1337	0662057A22	75
R1338	0662057A27	120
R1339	0662057A22	75
R1340	0662057A49	1K
R1341	0662057A25	100
R1342	0662057A25	100
R1343	0662057C55	150
R1344	0662057A49	1K
R1345	0662057A25	100
R1346	0662057A25	100
R1347	0662057C55	150
R1376	0662057A65	4.7K
R1402	0611079A64	390
R1404	0680194M18	51
R1405	0680194M18	51
R1406	0662057A73	10K
R1407	0662057A73	10K

Circuit Ref	Motorola Part No.	Description
R1409	0682089V01	.01
R1410	0683962T52	130
R1411	0662057C99	10K
R1413	0680194M01	10
R1414	0680194M01	10
R1416	0680194M01	10
R1417	0680194M01	10
R1418	0680194M01	10
R1419	0680194M01	10
R1420	0680194M01	10
R1421	0680194M01	10
R1422	0680194M01	10
R1423	0680194M01	10
R1424	0662057D10	27K
R1425	0662057D10	27K
R1440	0662057A25	100
R1442	0662057A25	100
R1443	0662057A49	1K
R1444	0662057A33	220
R1445	0662057A68	6.2K
R1447	0662057B47	0
R1449	0611079A64	390
R1450	0683962T71	820
R1451	0662057K31	180
R1453	0662057K31	180
R1454	0662057K31	180
R1457	0662057K01	10
R1458	0611079A64	390
R1459	0611079A64	390
R1460	0680106R01	0.1
R1463	0662057A75	12K
R1464	0662057A61	3.3K
R1465	0662057A61	3.3K
R1469	0662057C01	0
R1472	0662057A73	10K
R1473	0680194M01	10
R1474	0680194M01	10
R1475	0680194M01	10
R1476	0680194M01	10
R1477	0662057A61	3.3K
R1478	0662057A73	10K
R1479	0662057A61	3.3K
R1480	0662057D10	27K
R1481	0662057A90	51K
R1482	0662057B47	0
R1483	0662057A34	240
R1484	0662057A49	1K
R1501	0662057A45	680
R1502	0662057C67	470
R1503	0662057A61	3.3K
R1504	0662057A73	10K
R1505	0662057A69	6.8K
R1506	0662057A87	39K
R1507	0662057A49	1K
R1508	0662057R17	43.2
R1509	0662057P95	100K

Circuit Ref	Motorola Part No.	Description
R1511	0662057P95	100K
R1513	0662057C76	1.1K
R1514	0662057A97	100K
R1515	0662057A49	1K
R1516	0662057C71	680
R1517	0662057C71	680
R1518	0662057A61	3.3K
R1519	0662057C71	680
R1522	0662057A73	10K
R1524	0662057C71	680
R1526	0662057A97	100K
R1527	0662057A97	100K
R1528	0662057A80	20K
R1532	0662057A95	82K
R1533	0662057A73	10K
R1535	0662057R16	39.2
R1537	0662057A53	1.5K
R1541	0662057A53	1.5K
R1542	0662057A49	1K
R1543	0662057A49	1K
R1544	0662057A90	51K
R1545	0662057A65	4.7K
R1601	0662057A73	10K
R1602	0662057A65	4.7K
R1604	0662057A49	1K
R1605	0662057B10	330K
R1606	0662057B02	150K
R1607	0662057B19	750K
R1608	0662057A57	2.2K
R1609	0662057A73	10K
R1610	0662057A82	24K
R1611	0662057A49	1K
R1612	0662057A25	100
R1613	0662057A59	2.7K
R1614	0662057A49	1K
R1615	0662057A49	1K
R1616	0662057A33	220
R1617	0662057A57	2.2K
R1620	0662057A51	1.2K
R1621	0662057A68	6.2K
R1622	0662057A49	1K
R1626	0662057A18	51
R1627	0662057A73	10K
R1628	0662057A55	1.8K
R1629	0662057A67	5.6K
R1630	0662057A53	1.5K
R1631	0662057A18	51
R1632	0662057A82	24K
R1635	0662057B47	0
R1636	0662057A42	510
R1637	0662057A59	2.7K
R1638	0662057A55	1.8K
SH1302	2680473U01	VCO SHIELD
U1001	4802245J50	UMC5N
U1051	5108278X01	MIXER
U1101	5113805A86	MC74HC4066

Circuit Ref	Motorola Part No.	Description
U1102	5113805A86	MC74HC4066
U1103	5186144B01	SA616
U1201	5185963A27	FRACN SYNTHESIZER
U1250	5185963A33	LP2951
U1377	4802245J50	UMC5N
U1378	4802245J50	UMC5N
U1401	5185130C65	LD MOS PREDRIVER IC
U1402	5113818A03	MC33072
U1501	5185963A15	LM50
U1502	5109731C21	LM6142BIM
U1503	5185765B28	POWER CONTROL IC
U1601	5180929W01	MC1350
Y1101	4880908W08	CRYSTAL, 10.245 MHZ
Y1102	9186145B02	DISCRIMINATOR, 455 KHZ
Y1201	4880114R04	CRYSTAL, 16.8 MHZ
Y1202	NOTPLACED	

* Motorola Depot Servicing only
 Reference designators with an asterisk indicate components which are not fieldreplaceable because they need to be calibrated with specialized factory equipment after installation. Radios in which these parts have been replaced in the field will be off frequency at temperature extremes.

3.0 LB Range2 25-60W PCB 8486207B05 / Schematics

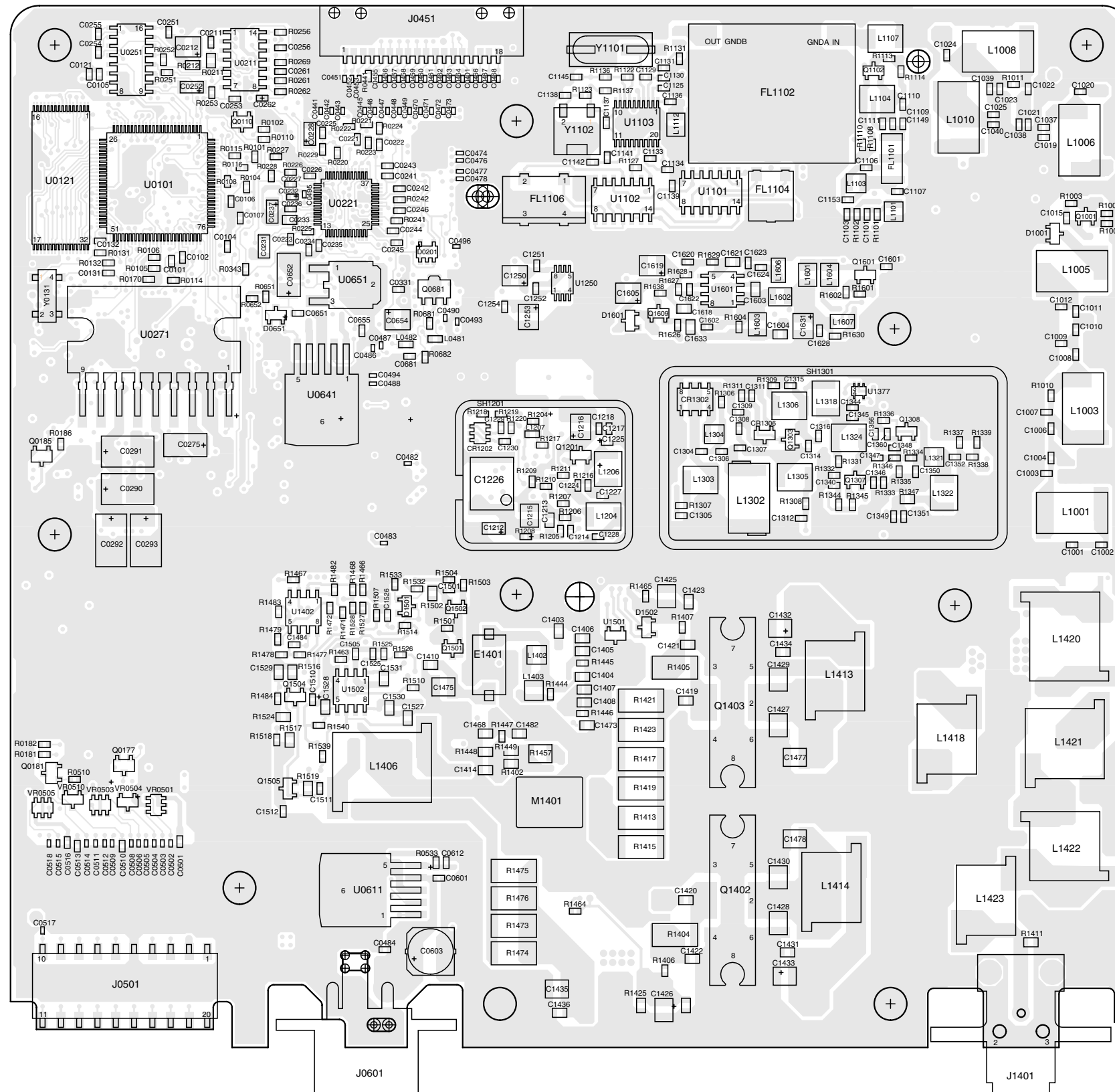

ZWG0130595-O
LB2 (36.0-42.0 MHz)
8486207B05 Top Side

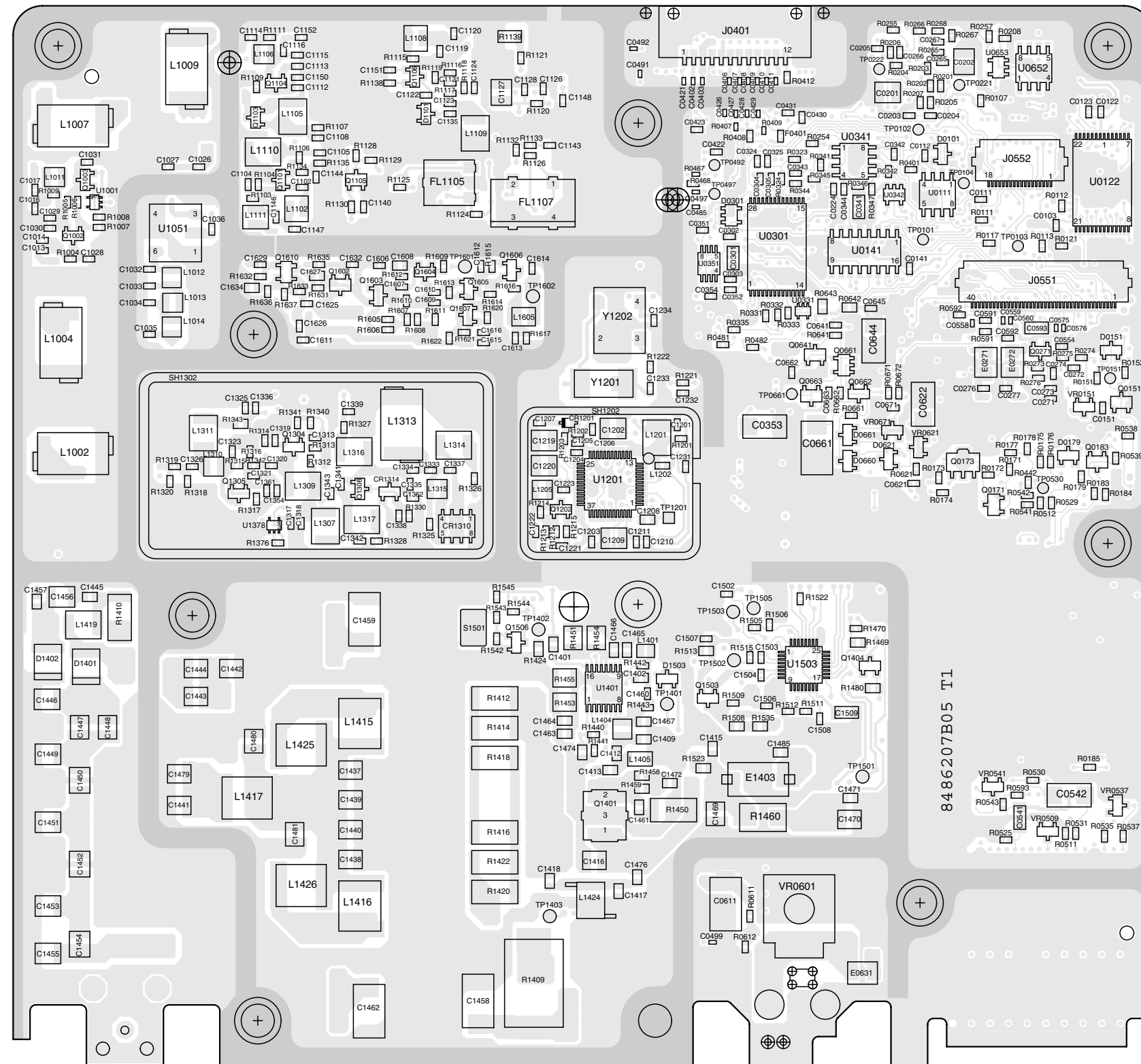

LB2 (36.0-42.0 MHz) 8486207B05 Bot Side

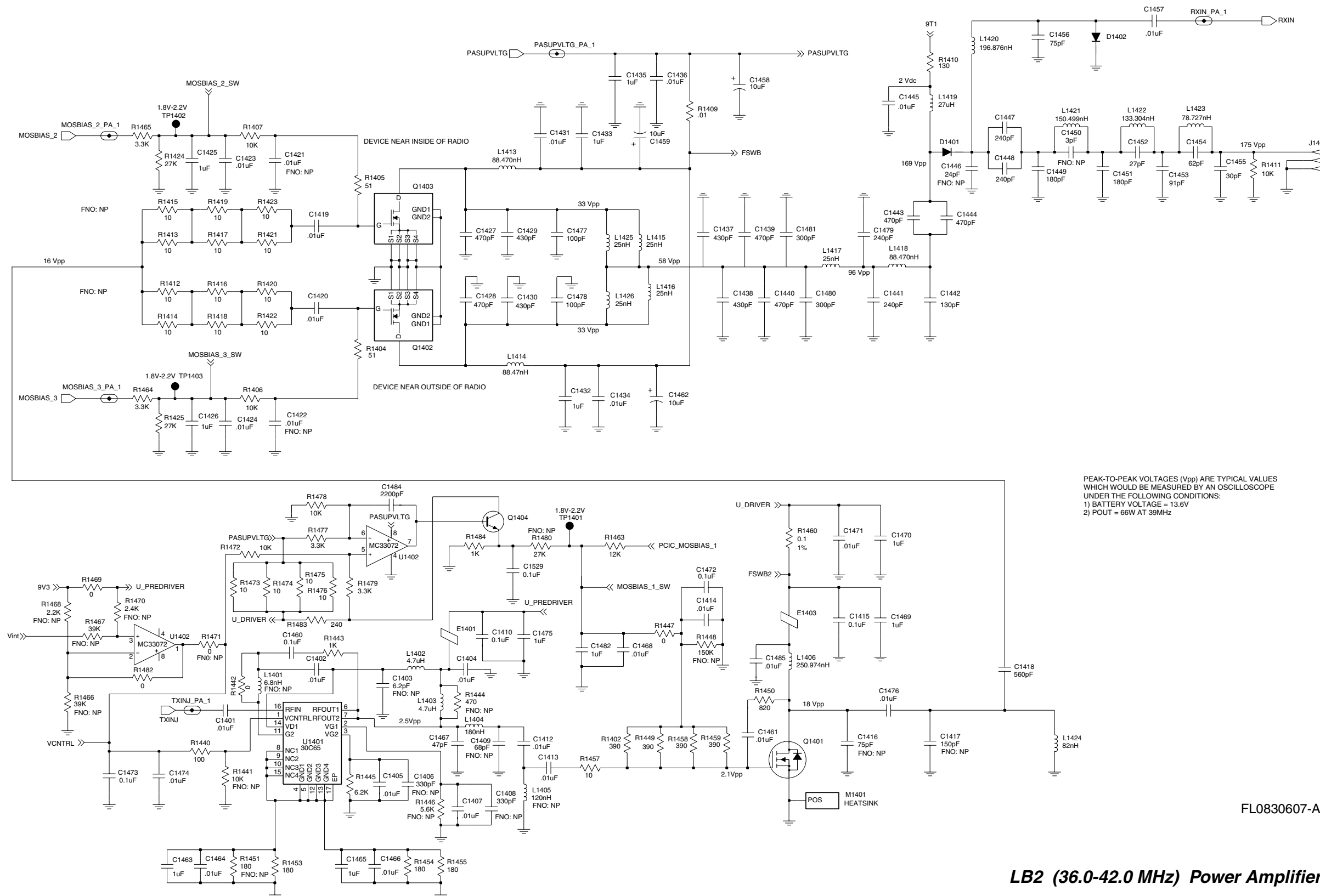

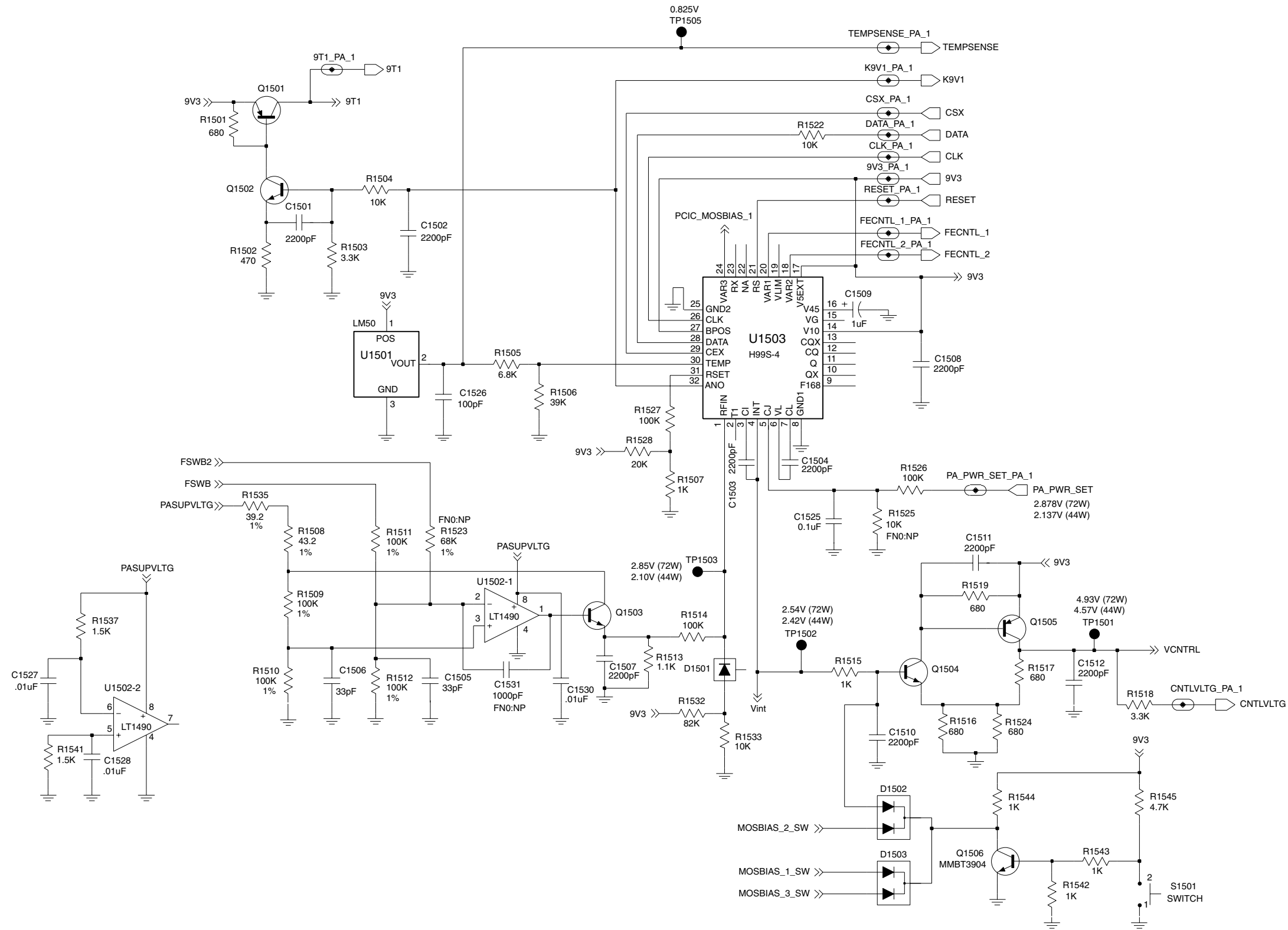

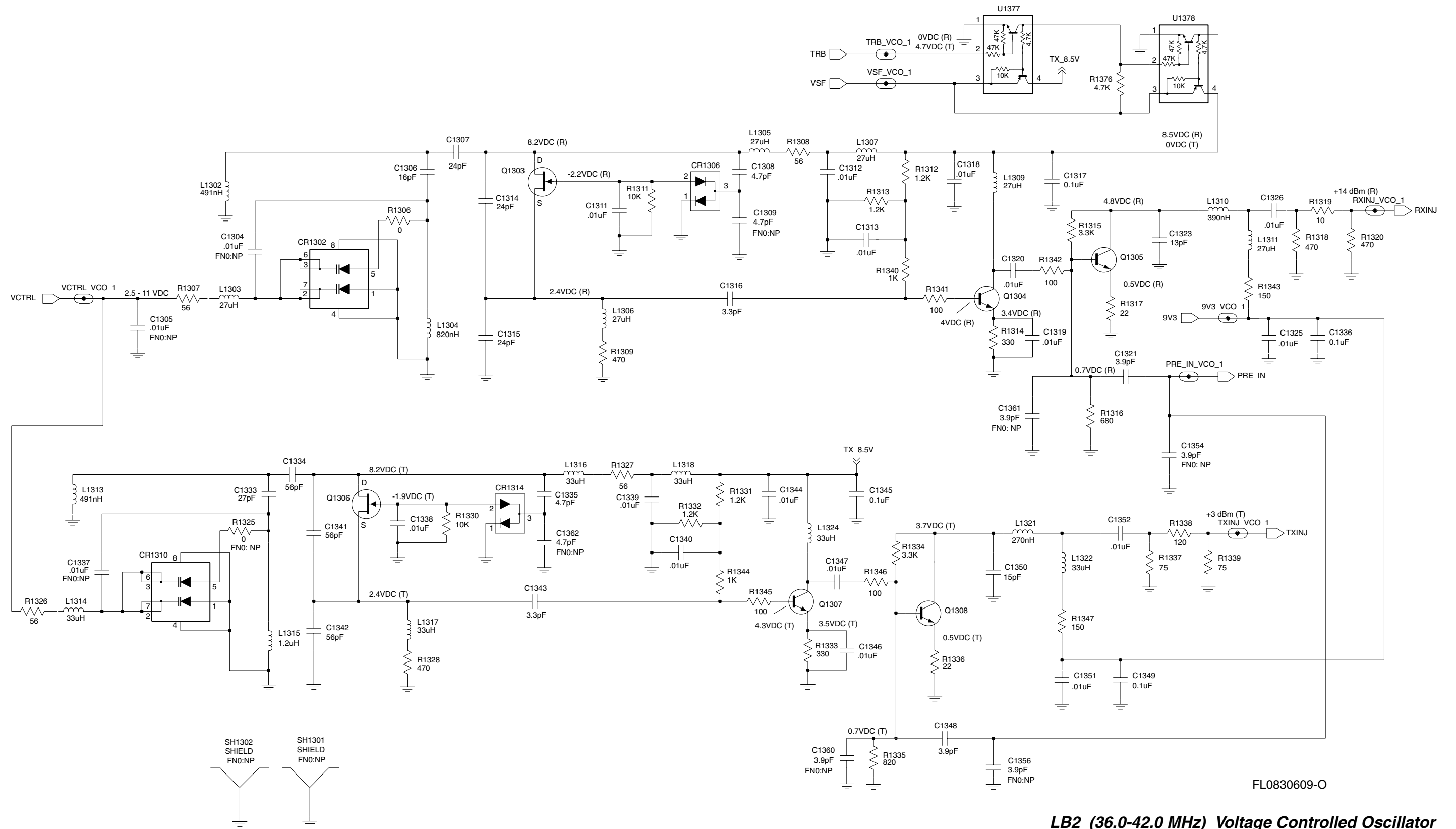

LB2 (36.0-42.0 MHz) Voltage Controlled Oscillator

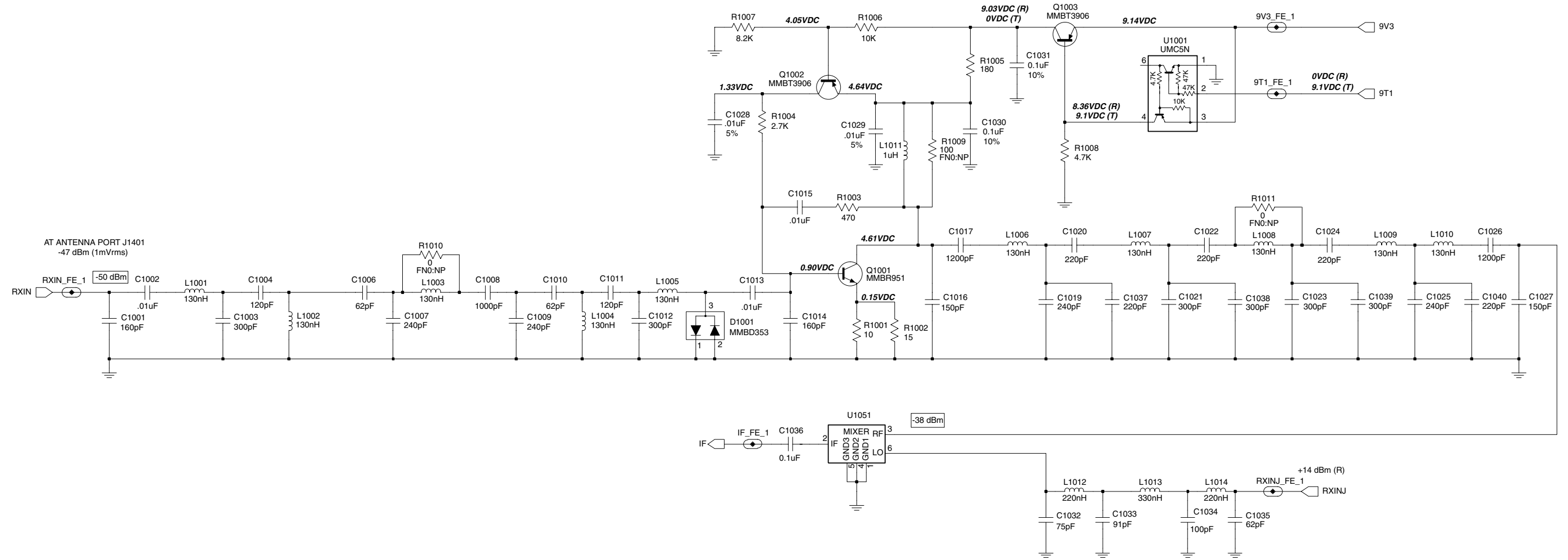

LB2 (36.0-42.0 MHz) Receiver Front End

FL0830599-A

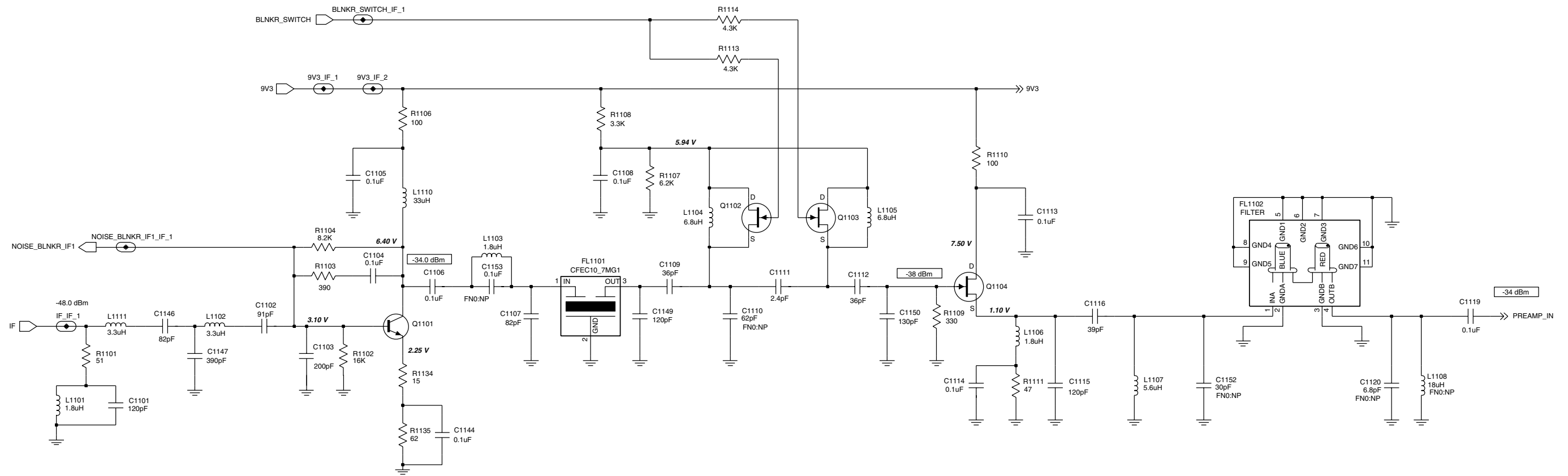

FL0830690-O

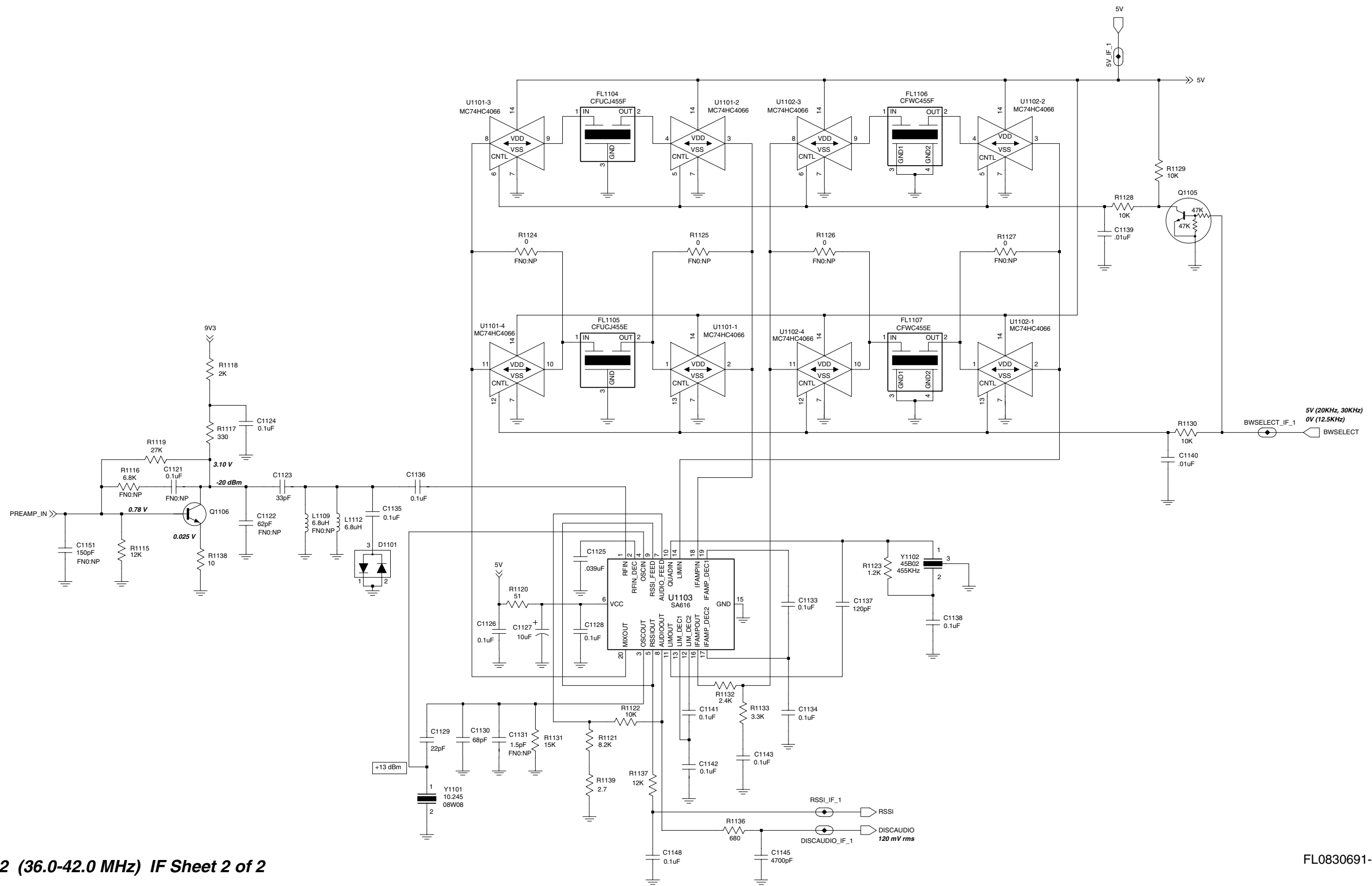

LB2 (36.0-42.0 MHz) IF Sheet 2 of 2

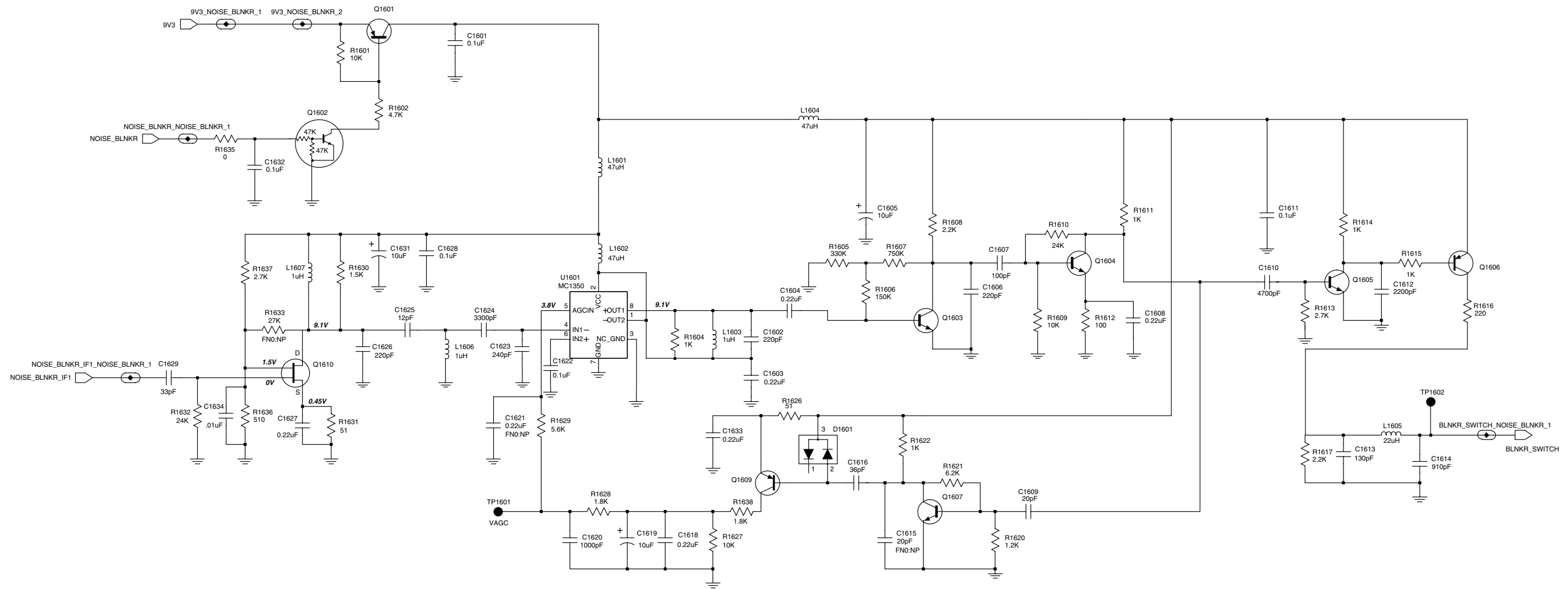

FL0830692-O

LB2 (36.0-42.0 MHz) Noise Blanker

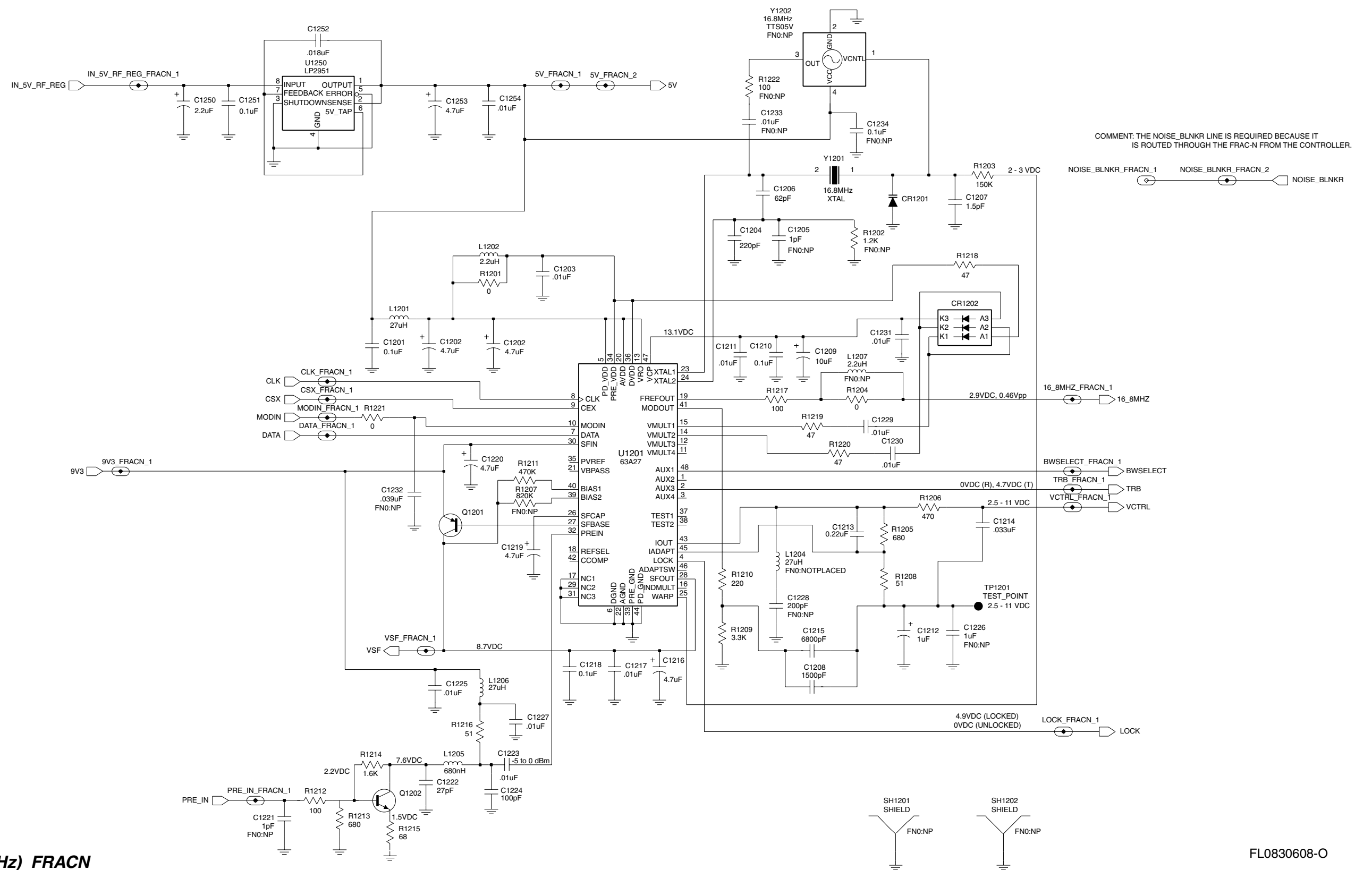

LB2 (36.0-42.0 MHz) FRACN

3.1 LB2 PCB 8486207B05 Parts List

Circuit Ref	Motorola Part No.	Description
C1001	2113740F56	160pF
C1002	2113741F49	.01uF
C1003	2113740F62	300pF
C1004	2113740F53	120pF
C1006	2113740F46	62pF
C1007	2113740F60	240pF
C1008	2113741F25	1000pF
C1009	2113740F60	240pF
C1010	2113740F46	62pF
C1011	2113740F53	120pF
C1012	2113740F62	300pF
C1013	2113741F49	.01uF
C1014	2113740F56	160pF
C1015	2113741F49	.01uF
C1016	2113740F55	150pF
C1017	2113741F27	1200pF
C1019	2113740F60	240pF
C1020	2113740F59	220pF
C1021	2113740F62	300pF
C1022	2113740F58	200pF
C1023	2113740F62	300pF
C1024	2113740F59	220pF
C1025	2113740F60	240pF
C1026	2113741F27	1200pF
C1027	2113740F55	150pF
C1028	2113741F49	.01uF
C1029	2113741F49	.01uF
C1030	2113743E20	0.1uF
C1031	2113743E20	0.1uF
C1032	2113740F48	75pF
C1033	2113740F50	91pF
C1034	2113740F51	100pF
C1035	2113740F46	62pF
C1036	2113743E20	0.1uF
C1037	2113740F59	220pF
C1038	2113740F62	300pF
C1039	2113740F62	300pF
C1040	2113740F59	220pF
C1101	2113740F53	120pF
C1102	2113740F50	91pF
C1103	2113740F58	200pF
C1104	2113743E20	0.1uF
C1105	2113743E20	0.1uF
C1106	2113743E20	0.1uF
C1107	2113740F49	82pF
C1108	2113743E20	0.1uF
C1109	2113740F40	36pF
C1111	2113740L03	2.4pF
C1112	2113740F40	36pF
C1113	2113743E20	0.1uF

Circuit Ref	Motorola Part No.	Description
C1114	2113743E20	0.1uF
C1115	2113740F53	120pF
C1116	2113740F39	33pF
C1119	2113743E20	0.1uF
C1123	2113740F39	33pF
C1124	2113743E20	0.1uF
C1125	2113743E11	.039uF
C1126	2113743E20	0.1uF
C1127	2311049A57	10uF
C1128	2113743E20	0.1uF
C1129	2113740F35	22pF
C1130	2113740F47	68pF
C1133 -		
C1136	2113743E20	0.1uF
C1137	2113740F53	120pF
C1138	2113743E20	0.1uF
C1139	2113741F49	.01uF
C1140	2113741F49	.01uF
C1141 -		
C1144	2113743E20	0.1uF
C1145	2113741F41	4700pF
C1146	2113740F49	82pF
C1147	2113740F65	390pF
C1148	2113743E20	0.1uF
C1149	2113740F53	120pF
C1150	2113740F54	130pF
C1201	2113743E20	0.1uF
C1202	2311049J11	4.7uF
C1203	2113741F49	.01uF
C1204	2113740F59	220pF
C1206	2113740L37	62pF
C1207	2113740F07	1.5pF
C1208	2113740A82	1500pF
C1209	2311049A57	10uF
C1210	2113743E20	0.1uF
C1211	2113741F49	.01uF
C1212	2311049A07	1uF
C1213	2113743A23	0.22uF
C1214	2113743E10	.033uF
C1215	2113740C37	6800pF
C1216	2311049J11	4.7uF
C1217	2113741F49	.01uF
C1218	2113743E20	0.1uF
C1219	2311049J11	4.7uF
C1220	2311049J11	4.7uF
C1222	2113740F36	24pF
C1223	2113741F49	.01uF
C1224	2113740F49	82pF
C1225	2113741F49	.01uF
C1227	2113741F49	.01uF
C1229	2113741F49	.01uF

Circuit Ref	Motorola Part No.	Description
C1230	2113741F49	.01uF
C1231	2113741F49	.01uF
C1250	2311049A09	2.2uF
C1251	2113743E20	0.1uF
C1252	2113743E05	.018uF
C1253	2311049J11	4.7uF
C1254	2113741F49	.01uF
C1306	2113740L23	16pF
C1307	2113740L27	24pF
C1308	2113740F19	4.7pF
C1311	2113741F49	.01uF
C1312	2113741F49	.01uF
C1313	2113741F49	.01uF
C1314	2113740L27	24pF
C1315	2113740L27	24pF
C1316	2113740F15	3.3pF
C1317	2113743E20	0.1uF
C1318	2113741F49	.01uF
C1319	2113741F49	.01uF
C1320	2113741F49	.01uF
C1321	2113740F17	3.9pF
C1323	2113740L21	13pF
C1325	2113741F49	.01uF
C1326	2113741F49	.01uF
C1333	2113740L28	27pF
C1334	2113740L36	56pF
C1335	2113740F19	4.7pF
C1336	2113743E20	0.1uF
C1338	2113741F49	.01uF
C1339	2113741F49	.01uF
C1340	2113741F49	.01uF
C1341	2113740L36	56pF
C1342	2113740L36	56pF
C1343	2113740F15	3.3pF
C1344	2113741F49	.01uF
C1345	2113743E20	0.1uF
C1346	2113741F49	.01uF
C1347	2113741F49	.01uF
C1348	2113740F17	3.9pF
C1349	2113743E20	0.1uF
C1350	2113740F31	15pF
C1351	2113741F49	.01uF
C1352	2113741F49	.01uF
C1401	2113741A45	.01uF
C1402	2113741A45	.01uF
C1404	2113741A45	.01uF
C1405	2113741A45	.01uF
C1407	2113741A45	.01uF
C1410	2113741M69	0.1uF
C1412	2113741A45	.01uF
C1413	2113741A45	.01uF

Circuit Ref	Motorola Part No.	Description
C1414	2113741A45	.01uF
C1415	2113741M69	0.1uF
C1418	2113740A73	560pF
C1419	2113741A45	.01uF
C1420	2113741A45	.01uF
C1423	2113741A45	.01uF
C1424	2113741A45	.01uF
C1425	2113741W01	1uF
C1426	2113741W01	1uF
C1427	2111078B59	470pF
C1428	2111078B59	470pF
C1429	2111078B58	430pF
C1430	2111078B58	430pF
C1431	2113741A45	.01uF
C1432	2113741W01	1uF
C1433	2113741W01	1uF
C1434	2113741A45	.01uF
C1435	2113741W01	1uF
C1436	2113741A45	.01uF
C1437	2111078B58	430pF
C1438	2111078B58	430pF
C1439	2111078B59	470pF
C1440	2111078B59	470pF
C1441	2111078B52	240pF
C1442	2111078B45	130pF
C1443	2111078B59	470pF
C1444	2111078B59	470pF
C1445	2113741A45	.01uF
C1447	2111078B52	240pF
C1448	2111078B52	240pF
C1449	2180060M49	180pF
C1451	2180060M49	180pF
C1452	2180060M29	27pF
C1453	2180060M42	91pF
C1454	2180060M38	62pF
C1455	2180060M30	30pF
C1456	2180060M40	75pF
C1457	2113741A45	.01uF
C1458	2311049C01	10uF
C1459	2311049C01	10uF
C1460	2113743E20	0.1uF
C1461	2113741A45	.01uF
C1462	2311049C01	10uF
C1463	2113928E01	1uF
C1464	2113741A45	.01uF
C1465	2113928E01	1uF
C1466	2113741A45	.01uF
C1467	2113740A46	47pF
C1468	2113741A45	.01uF
C1469	2113741W01	1uF
C1470	2113741W01	1uF

Circuit Ref	Motorola Part No.	Description
C1471	2113741A45	.01uF
C1472	2113741M69	0.1uF
C1473	2113741M69	0.1uF
C1474	2113741A45	.01uF
C1475	2113741W01	1uF
C1476	2113741A45	.01uF
C1477	2111078B42	100pF
C1478	2111078B42	100pF
C1479	2111078B52	240pF
C1480	2111078B54	300pF
C1481	2111078B54	300pF
C1482	2113928E01	1uF
C1484	2113741F33	2200pF
C1485	2113741A45	.01uF
C1501	2113741F33	2200pF
C1502	2113741F33	2200pF
C1503	2113741F33	2200pF
C1504	2113741F33	2200pF
C1505	2113741F25	1nF
C1506	2113741F25	1nF
C1507	2113741F33	2200pF
C1508	2113741F33	2200pF
C1509	2311049A07	1uF
C1510	2113741F33	2200pF
C1511	2113741F33	2200pF
C1512	2113741F33	2200pF
C1525	2113743E20	0.1uF
C1526	2113740F51	100pF
C1527	2113741A45	.01uF
C1528	2113741A45	.01uF
C1529	2113741M69	0.1uF
C1530	2113741A45	.01uF
C1601	2113743E20	0.1uF
C1602	2113740F59	220pF
C1603	2113743A23	0.22uF
C1604	2113743A23	0.22uF
C1605	2311049A57	10uF
C1606	2113740F59	220pF
C1607	2113740F51	100pF
C1608	2113743A23	0.22uF
C1609	2113740F34	20pF
C1610	2113741F41	4700pF
C1611	2113743E20	0.1uF
C1612	2113741F33	2200pF
C1613	2113740F54	130pF
C1614	2113741F24	910pF
C1616	2113740F40	36pF
C1618	2113743A23	0.22uF
C1619	2311049A57	10uF
C1620	2113741F25	1000pF
C1622	2113743E20	0.1uF

Circuit Ref	Motorola Part No.	Description
C1623	2113740F60	240pF
C1624	2113741F37	3300pF
C1625	2113740F29	12pF
C1626	2113740F59	220pF
C1627	2113743A23	0.22uF
C1628	2113743E20	0.1uF
C1629	2113740F39	33pF
C1631	2311049A57	10uF
C1632	2113743E20	0.1uF
C1633	2113743A23	0.22uF
C1634	2113741A45	.01uF
CR1201	4802245J22	1T363
CR1202	4802233J09	IMN10
CR1302	4805649Q14	HN1V02H
CR1306	4880154K03	MMBD353
CR1310	4805649Q14	HN1V02H
CR1314	4880154K03	MMBD353
D1001	4880154K03	MMBD353
D1101	4880154K03	MMBD353
D1401	4808379X02	MA4P1450
D1402	4808379X02	MA4P1450
D1501	4880236E05	MMBD301
D1502	4813833C02	MMBD6100
D1503	4813833C02	MMBD6100
D1601	4880154K03	MMBD353
E1401	2408380X02	2773037446
E1403	2408380X02	2773037446
FL1101	9180656U03	CFEC10_7MG1
FL1102	9180022M09	FILTER
FL1104	9180468V04	CFUCJ455F
FL1105	9180468V05	CFUCJ455E
FL1106	9180469V04	CFWC455F
FL1107	9180469V05	CFWC455E
J1401	0986166B02	CONN_J
L1001 -		
L1010	2408382A11	130nH
L1011	2462587N68	1uH
L1012	2462587N57	220nH
L1013	2462587N59	330nH
L1014	2462587N57	220nH
L1101	2462587N33	1.8uH
L1102	2408383X07	3.3uH
L1103	2462587N33	1.8uH
L1104	2480289M10	6.8uH
L1105	2480289M10	6.8uH
L1106	2462587N33	1.8uH
L1107	2480289M10	6.8uH
L1110	2480289M18	33uH
L1111	2408383X07	3.3uH
L1112	2483411T35	6.8uH
L1201	2480289M17	27uH

Circuit Ref	Motorola Part No.	Description
L1202	2462587Q20	2.2uH
L1205	2462587N62	560nH
L1206	2480289M17	27uH
L1302	2408382D19	491nH
L1303	2480289M17	27uH"
L1304	2462587N66	820nH
L1305	2480289M17	27uH
L1306	2480289M17	27uH
L1307	2480289M17	27uH
L1309	2480289M17	27uH
L1310	2462587N60	390nH
L1311	2480289M17	27uH
L1313	2408382D19	491nH
L1314	2480289M18	33uH
L1315	2462587N69	1.2uH
L1316	2480289M18	33uH
L1317	2480289M18	33uH
L1318	2480289M18	33uH
L1321	2462587N58	270nH
L1322	2480289M18	33uH
L1324	2480289M18	33uH
L1402	2462587U09	4.7uH
L1403	2462587U09	4.7uH
L1404	2462587N56	180nH
L1406	2408381X36	250.974nH
L1413	2408381X17	88.470nH
L1414	2408381X17	88.470nH
L1415	2460591X02	25nH
L1416	2460591X02	25nH
L1417	2460591X02	25nH
L1418	2408381X17	88.470nH
L1419	2480289M17	27uH
L1420	2408381X31	196.876nH
L1421	2408381X27	150.499nH
L1422	2408381X24	133.304nH
L1423	2408381X15	78.727nH
L1424	2408384A08	82nH
L1425	2460591X02	25nH
L1426	2460591X02	25nH
L1601	2483411T45	47uH
L1602	2483411T45	47uH
L1603	2483411T73	1uH
L1604	2483411T45	47uH
L1605	2483411T41	22uH
L1606	2462587T30	1uH
L1607	2462587T30	1uH
M1401	2686201B01	HEATSINK
Q1001	4880173R01	MMBR951
Q1002	4813824A17	MMBT3906
Q1003	4813824A17	MMBT3906
Q1101	4813827A07	MMBR941

Circuit Ref	Motorola Part No.	Description
Q1102	4813823A05	MMBFU310L
Q1103	4813823A05	MMBFU310L
Q1104	4813823A05	MMBFU310L
Q1105	4880048M01	DTC144EKA
Q1106	4813827A07	MMBR941
Q1201	4813824A17	MMBT3906
Q1202	4880173R01	MMBR951
Q1303	4884235R02	MMBFU310
Q1304	4880173R01	MMBR951
Q1305	4880173R01	MMBR951
Q1306	4884235R02	MMBFU310
Q1307	4880173R01	MMBR951
Q1308	4880173R01	MMBR951
Q1401	4886212B01	MRF1518
Q1402	4886136B01	36B01
Q1403	4886136B01	36B01
Q1501	4880141L03	BCW68G
Q1502	4813824A10	MMBT3904
Q1503	4813824A10	MMBT3904
Q1504	4813824A10	MMBT3904
Q1505	4813824A17	MMBT3906
Q1506	4813824A10	MMBT3904
Q1601	4813824A17	MMBT3906
Q1602	4880048M01	DTC144EKA
Q1603	4813824A10	MMBT3904
Q1604	4813824A10	MMBT3904
Q1605	4813824A10	MMBT3904
Q1606	4813824A17	MMBT3906
Q1607	4813824A10	MMBT3904
Q1609	4813824A17	MMBT3906
Q1610	4805585Q17	NE25139
R1001	0662057A05	15
R1002	0662057A05	15
R1003	0662057A41	470
R1004	0662057A59	2.7K
R1005	0662057A31	180
R1006	0662057A73	10K
R1007	0662057A71	8.2K
R1008	0662057A65	4.7K
R1101	0662057A18	51
R1102	0662057A78	16K
R1103	0662057A39	390
R1104	0662057A71	8.2K
R1106	0662057A25	100
R1107	0662057A68	6.2K
R1108	0662057A61	3.3K
R1109	0662057A37	330
R1110	0662057A25	100
R1111	0662057A17	47
R1113	0662057A64	4.3K
R1114	0662057A64	4.3K

Circuit Ref	Motorola Part No.	Description
R1115	0662057A75	12K
R1117	0662057A37	330
R1118	0662057A56	2K
R1119	0662057A83	27K
R1120	0662057A18	51
R1121	0662057A71	8.2K
R1122	0662057A73	10K
R1123	0662057A51	1.2K
R1128 -		
R1130	0662057A73	10K
R1131	0662057A77	15K
R1132	0662057A58	2.4K
R1133	0662057A61	3.3K
R1134	0662057A05	15
R1135	0662057A20	62
R1136	0662057A45	680
R1137	0662057A75	12K
R1138	0662057A01	10
R1139	0611077A12	2.7
R1201	0662057B47	0
R1203	0662057B02	150K
R1204	0662057B47	0
R1205	0662057A45	680
R1206	0662057A41	470
R1208	0662057A18	51
R1209	0662057A61	3.3K
R1210	0662057A33	220
R1211	0662057B14	470K
R1212	0662057A25	100
R1213	0662057A45	680
R1214	0662057A54	1.6K
R1215	0662057A21	68
R1216	0662057A18	51
R1217	0662057A25	100
R1218 -		
R1220	0662057A17	47
R1221	0662057B47	0
R1306	0662057B47	0
R1307	0662057A19	56
R1308	0662057A19	56
R1309	0662057A41	470
R1311	0662057A73	10K
R1312	0662057A51	1.2K
R1313	0662057A51	1.2K
R1314	0662057A37	330
R1315	0662057A61	3.3K
R1316	0662057A45	680
R1317	0662057A09	22
R1318	0662057A41	470
R1319	0662057A01	10
R1320	0662057A41	470

Circuit Ref	Motorola Part No.	Description
R1325	0662057B47	0
R1326	0662057A19	56
R1327	0662057A19	56
R1328	0662057A41	470
R1330	0662057A73	10K
R1331	0662057A51	1.2K
R1332	0662057A51	1.2K
R1333	0662057A37	330
R1334	0662057A61	3.3K
R1335	0662057A47	820
R1336	0662057A09	22
R1337	0662057A22	75
R1338	0662057A27	120
R1339	0662057A22	75
R1340	0662057A49	1K
R1341	0662057A25	100
R1342	0662057A25	100
R1343	0662057C55	150
R1344	0662057A49	1K
R1345	0662057A25	100
R1346	0662057A25	100
R1347	0662057C55	150
R1376	0662057A65	4.7K
R1402	0611079A64	390
R1404	0680194M18	51
R1405	0680194M18	51
R1406	0662057A73	10K
R1407	0662057A73	10K
R1409	0682089V01	.01
R1410	0683962T52	130
R1411	0662057C99	10K
R1413	0680194M01	10
R1414	0680194M01	10
R1416 -		
R1423	0680194M01	10
R1424	0611079B27	150K
R1425	0611079B27	150K
R1440	0662057A25	100
R1442	0662057B47	0
R1443	0662057A49	1K
R1445	0662057A68	6.2K
R1447	0662057B47	0
R1449	0611079A64	390
R1450	0683962T71	820
R1453 -		
R1455	0662057K31	180
R1457	0662057K01	10
R1458	0611079A64	390
R1459	0611079A64	390
R1460	0680106R01	0.1
R1463	0662057A93	68K

Circuit Ref	Motorola Part No.	Description
R1464	0662057A73	10K
R1465	0662057A73	10K
R1469	0662057C01	0
R1472	0662057A73	10K
R1473 -		
R1476	0680194M01	10
R1477	0662057A61	3.3K
R1478	0662057A73	10K
R1479	0662057A61	3.3K
R1480	0611079B27	150K
R1482	0662057B47	0
R1483	0662057A34	240
R1484	0662057A49	1K
R1501	0662057A45	680
R1502	0662057C67	470
R1503	0662057A61	3.3K
R1504	0662057A73	10K
R1505	0662057A69	6.8K
R1506	0662057A87	39K
R1507	0662057A49	1K
R1508	0662057R17	43.2
R1509	0662057P95	100K
R1511	0662057P95	100K
R1513	0662057C76	1.1K
R1514	0662057A97	100K
R1515	0662057A49	1K
R1516	0662057C71	680
R1517	0662057C71	680
R1518	0662057A61	3.3K
R1519	0662057C71	680
R1522	0662057A73	10K
R1524	0662057C71	680
R1526	0662057A97	100K
R1527	0662057A97	100K
R1528	0662057A80	20K
R1532	0662057A95	82K
R1533	0662057A73	10K
R1535	0662057R16	39.2
R1539	0662057A53	1.5K
R1540	0662057A53	1.5K
R1542 -		
R1544	0662057A49	1K
R1545	0662057A65	4.7K
R1601	0662057A73	10K
R1602	0662057A65	4.7K
R1604	0662057A49	1K
R1605	0662057B10	330K
R1606	0662057B02	150K
R1607	0662057B19	750K
R1608	0662057A57	2.2K
R1609	0662057A73	10K

Circuit Ref	Motorola Part No.	Description
R1610	0662057A82	24K
R1611	0662057A49	1K
R1612	0662057A25	100
R1613	0662057A59	2.7K
R1614	0662057A49	1K
R1615	0662057A49	1K
R1616	0662057A33	220
R1617	0662057A57	2.2K
R1620	0662057A51	1.2K
R1621	0662057A68	6.2K
R1622	0662057A49	1K
R1626	0662057A18	51
R1627	0662057A73	10K
R1628	0662057A55	1.8K
R1629	0662057A67	5.6K
R1630	0662057A53	1.5K
R1631	0662057A18	51
R1632	0662057A82	24K
R1635	0662057B47	0
R1636	0662057A42	510
R1637	0662057A59	2.7K
R1638	0662057A55	1.8K
U1001	4802245J50	UMC5N
U1051	5108278X01	MIXER
U1101	5113805A86	MC74HC4066
U1102	5113805A86	MC74HC4066
U1103	5186144B01	SA616
U1201	5185963A27	63A27
U1250	5185963A33	LP2951
U1377	4802245J50	UMC5N
U1378	4802245J50	UMC5N
U1401	5185130C65	30C65
U1402	5113818A03	MC33072
U1501	5185963A15	LM50
U1502	5180932W01	LT1490
U1503	5185765B01	H99S-4
U1601	5180929W01	MC1350
Y1101	4880908W08	08W08
Y1102	9186145B02	45B02
*Y1201	4880114R04	XTAL
Y1202	NOTPLACED	

* Motorola Depot Servicing only
Reference designators with an asterisk indicate components which are not fieldreplaceable because they need to be calibrated with specialized factory equipment after installation. Radios in which these parts have been replaced in the field will be off frequency at temperature extremes.

4.0 LB Range3 25-60W PCB 8485908z03 / Schematics

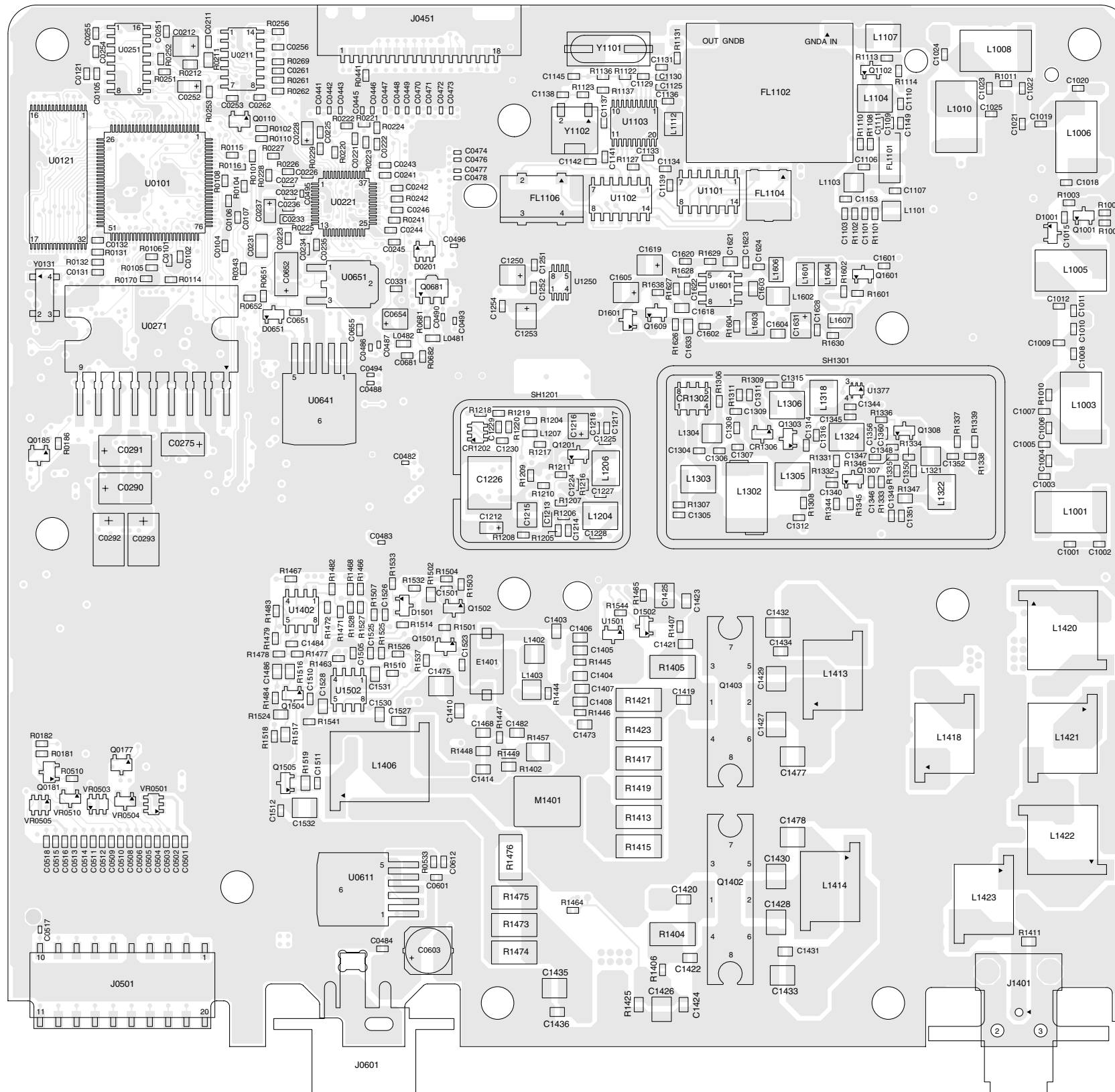

FL0830651-O
***LB3 (42.0-50.0 MHz)
 8485908z03 Top Side***

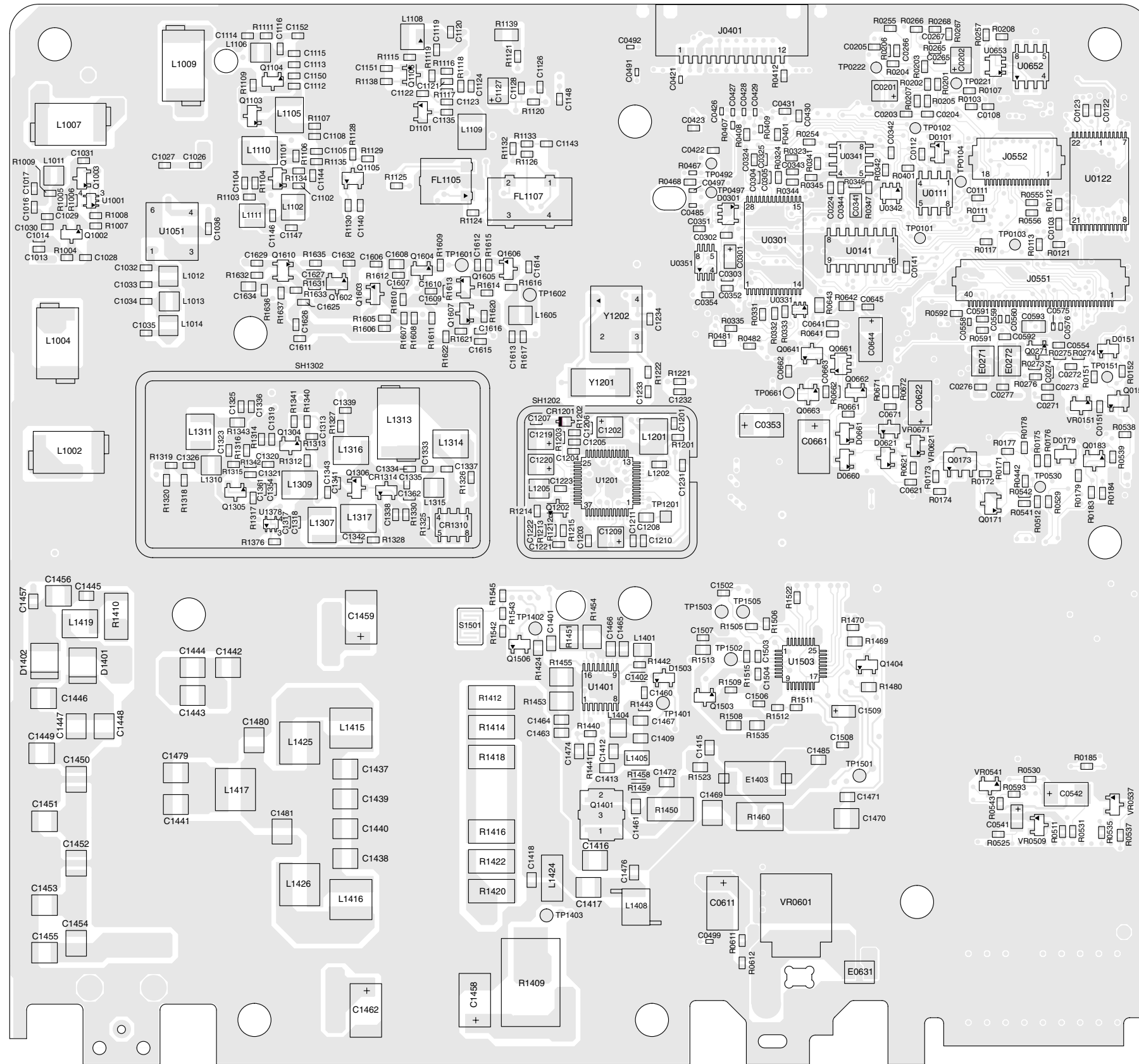

LB3 (42.0-50.0 MHz) 8485908z03 Bot Side

FL0830652-O

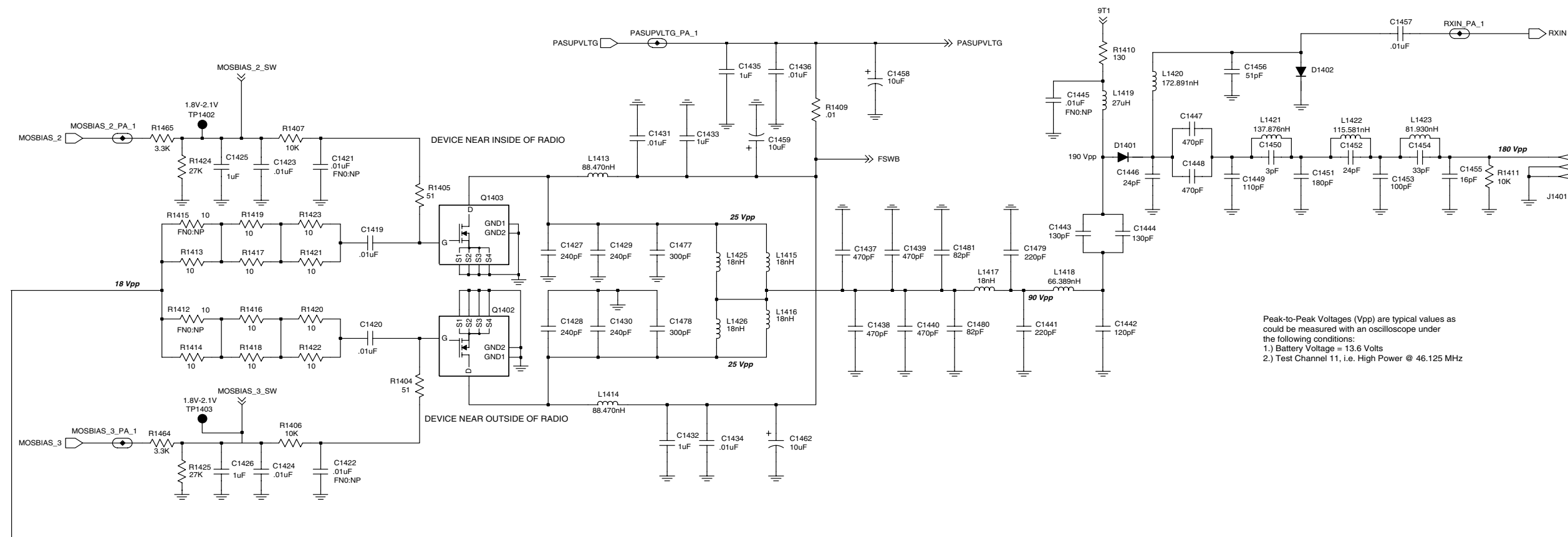

Peak-to-Peak Voltages (Vpp) are typical values as could be measured with an oscilloscope under the following conditions:
 1.) Battery Voltage = 13.6 Volts
 2.) Test Channel 11, i.e. High Power @ 46.125 MHz

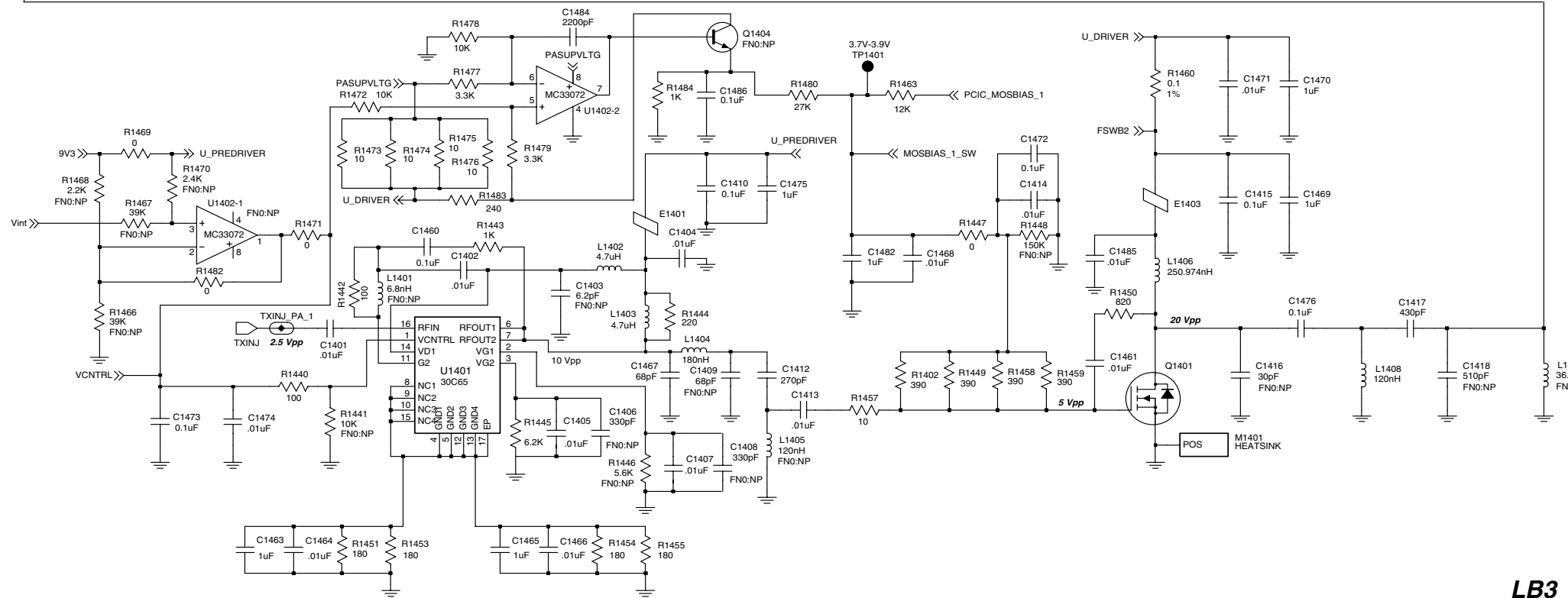

FL0830695-O

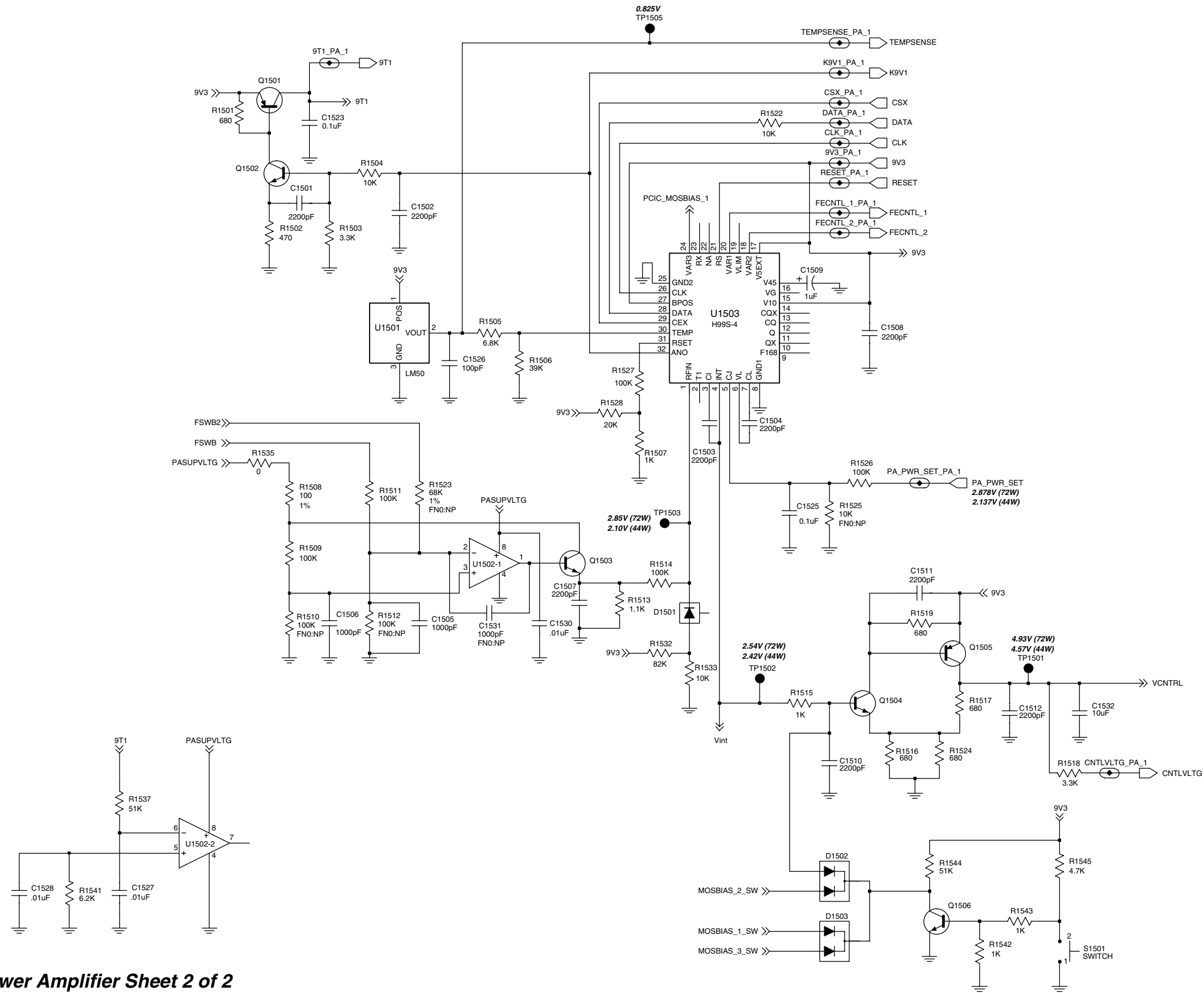

FL0830696-O

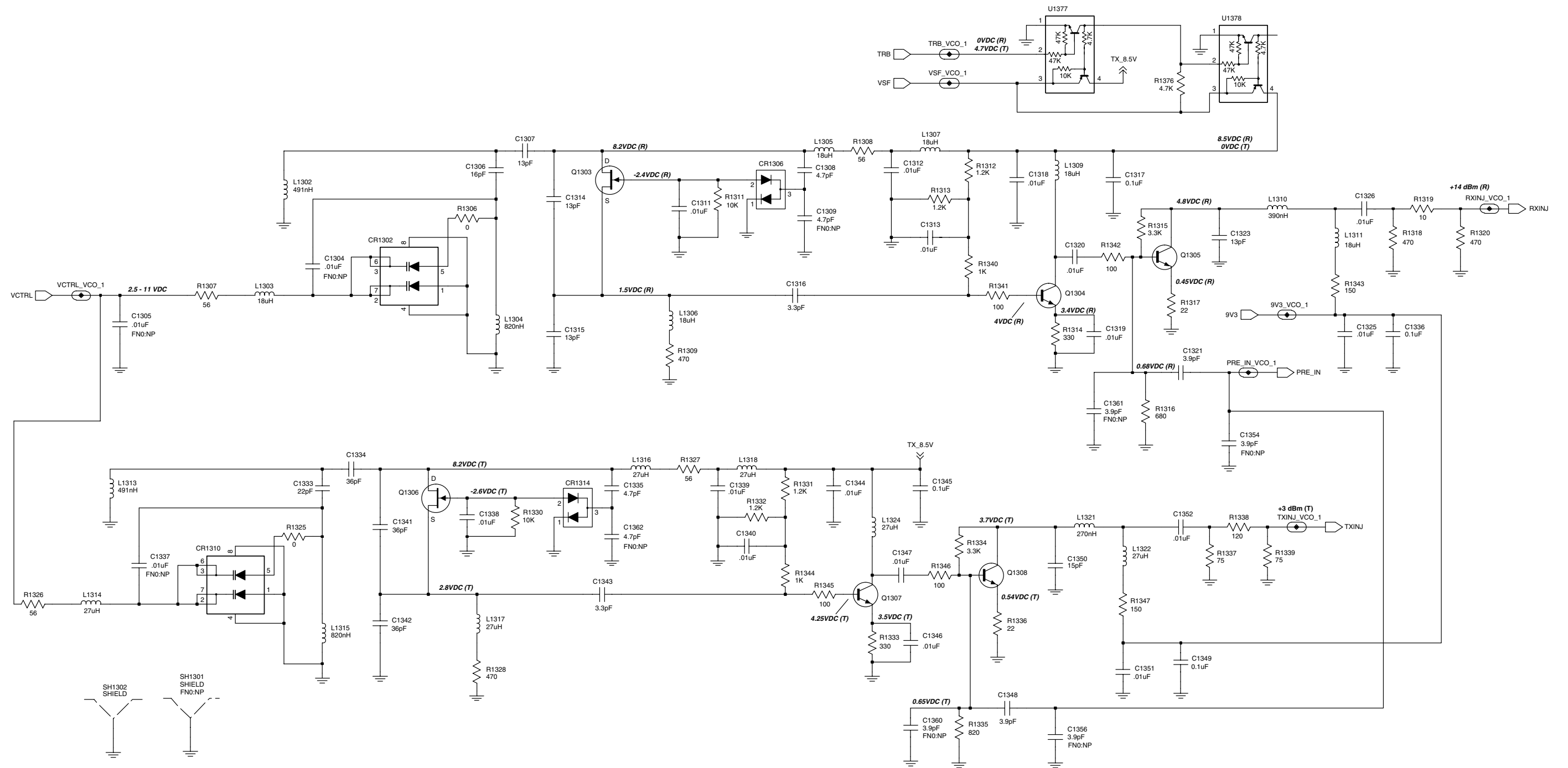

FL0830694-O

LB3 (42.0-50.0 MHz) Voltage Controlled Oscillator

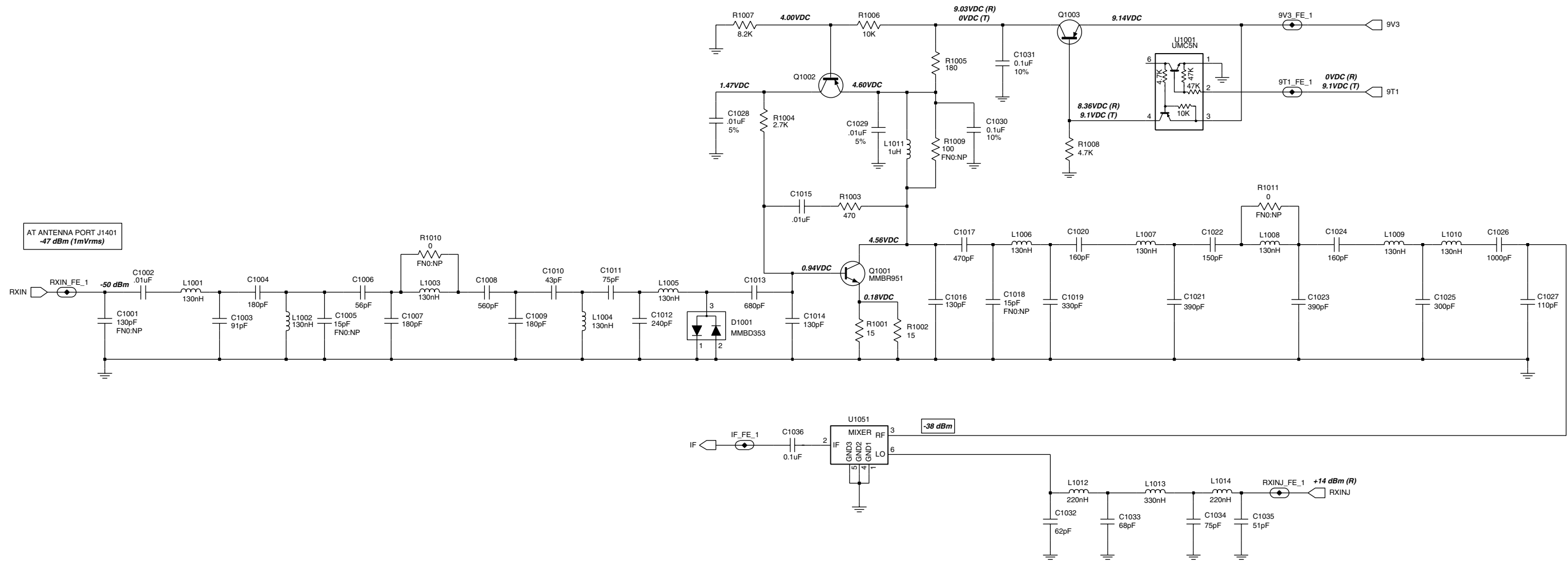

FL0830697-O

LB3 (42.0-50.0 MHz) Receiver Front End

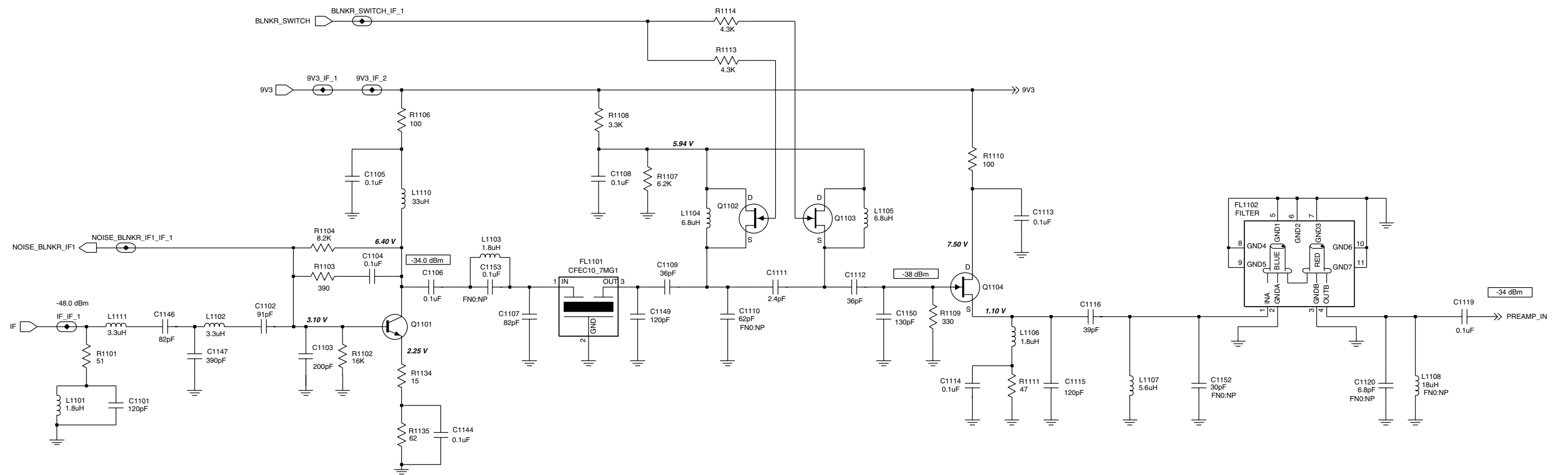

FL0830690-O

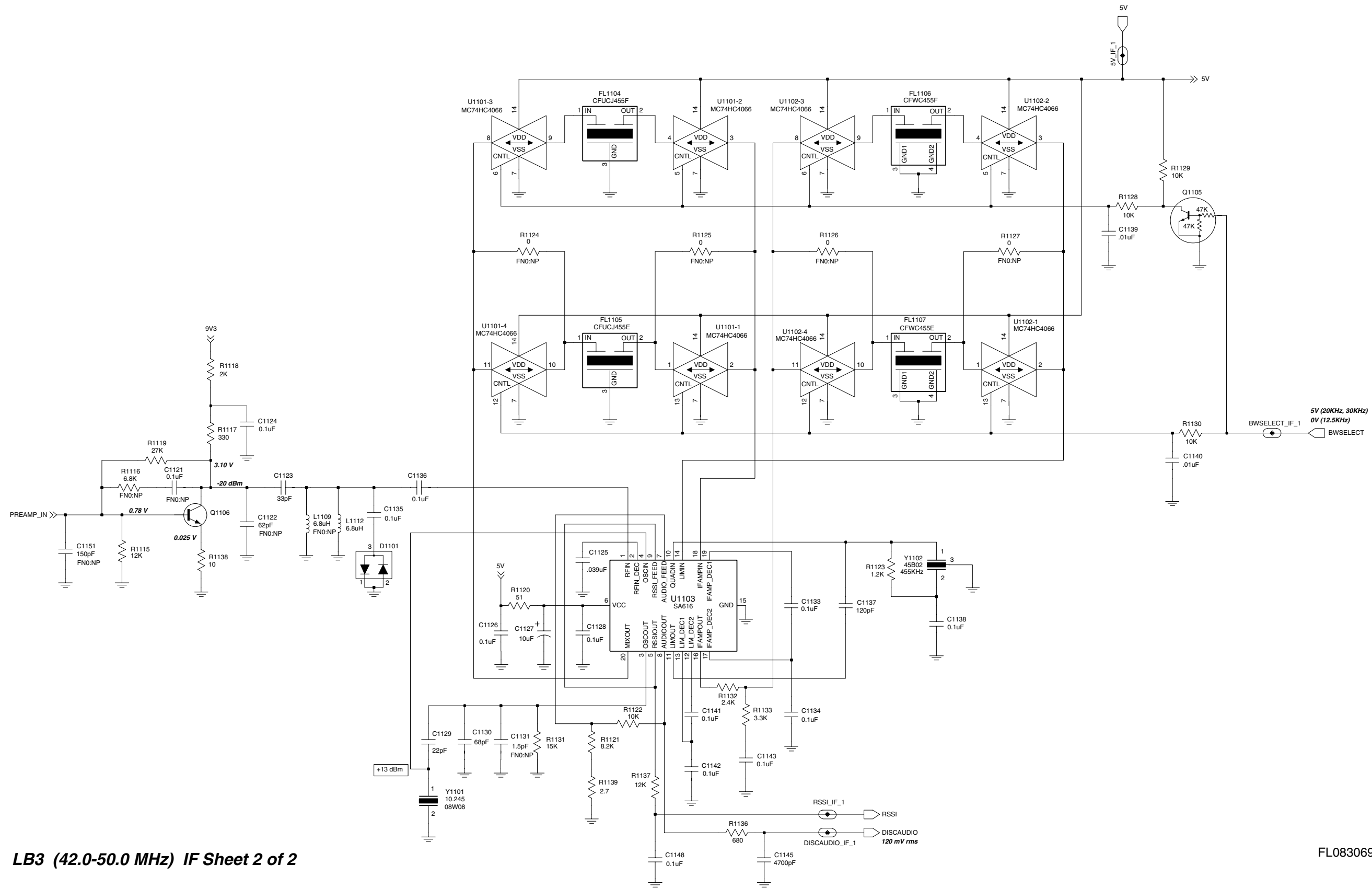

LB3 (42.0-50.0 MHz) IF Sheet 2 of 2

FL0830691-O

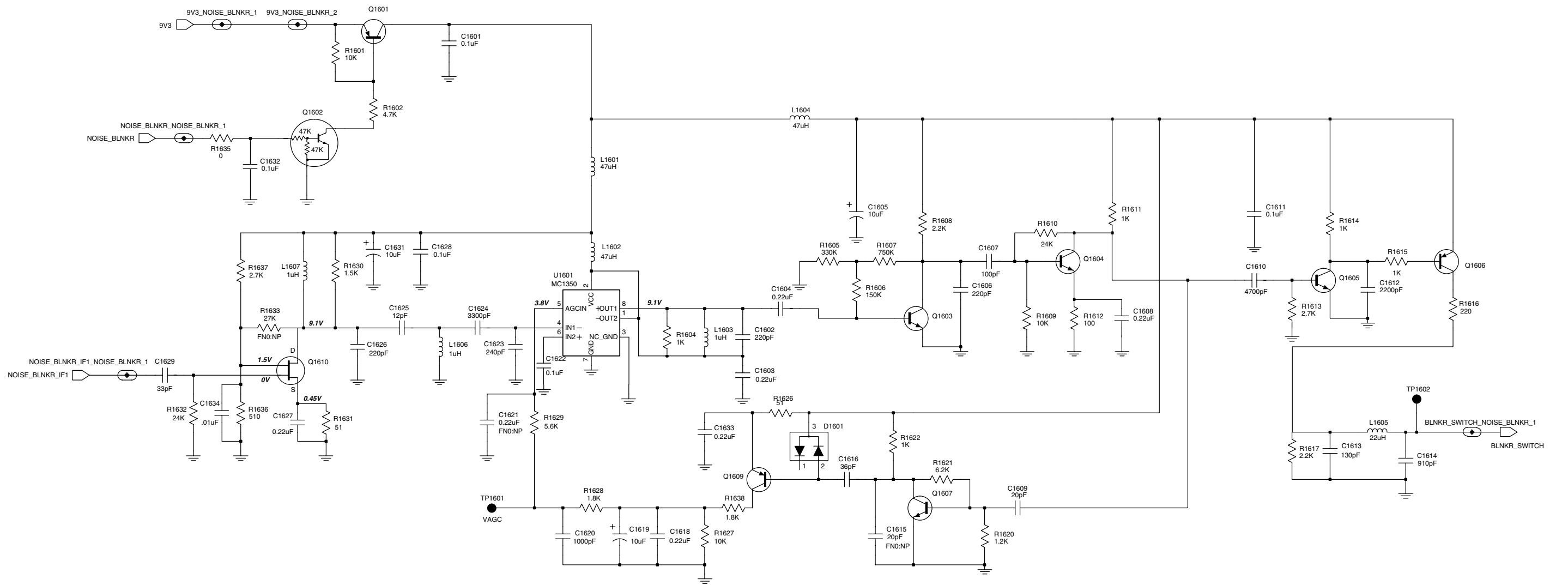

FL0830692-O

LB3 (42.0-50.0 MHz) Noise Blanker

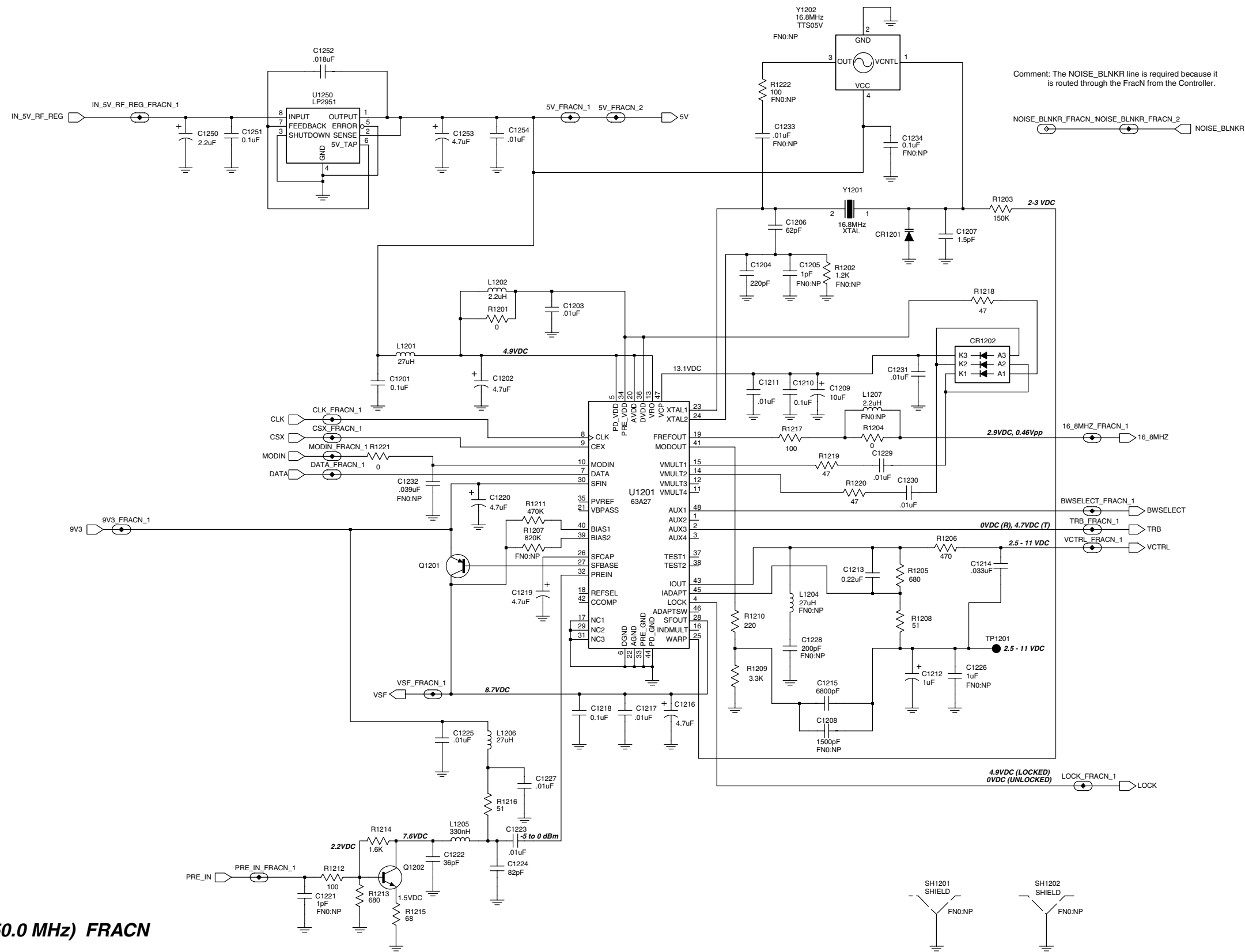

LB3 (42.0-50.0 MHz) FRACN

FL0830693-O

4.1 LB3 PCB 8485908z03 Parts List

Circuit Ref	Motorola Part No.	Description
C1001	NOTPLACED	
C1002	2113741F49	.01uF
C1003	2113740F50	91pF
C1004	2113740F57	180pF
C1006	2113740F45	56pF
C1007	2113740F57	180pF
C1008	2113740F69	560pF
C1009	2113740F57	180pF
C1010	2113740F42	43pF
C1011	2113740F48	75pF
C1012	2113740F60	240pF
C1013	2113741F21	680pF
C1014	2113740F54	130pF
C1015	2113741F49	.01uF
C1016	2113740F54	130pF
C1017	2113740F67	470pF
C1019	2113740F63	330pF
C1020	2113740F56	160pF
C1021	2113740F65	390pF
C1022	2113740F55	150pF
C1023	2113740F65	390pF
C1024	2113740F56	160pF
C1025	2113740F62	300pF
C1026	2113741F25	1000pF
C1027	2113740F52	110pF
C1028	2113741F49	.01uF
C1029	2113741F49	.01uF
C1030	2113743E20	0.1uF
C1031	2113743E20	0.1uF
C1032	2113740F46	62pF
C1033	2113740F47	68pF
C1034	2113740F48	75pF
C1035	2113740F44	51pF
C1036	2113743E20	0.1uF
C1101	2113740F53	120pF
C1102	2113740F50	91pF
C1103	2113740F58	200pF
C1104	2113743E20	0.1uF
C1105	2113743E20	0.1uF
C1106	2113743E20	0.1uF
C1107	2113740F49	82pF
C1108	2113743E20	0.1uF
C1109	2113740F40	36pF
C1111	2113740L03	2.4pF
C1112	2113740F40	36pF
C1113	2113743E20	0.1uF
C1114	2113743E20	0.1uF
C1115	2113740F53	120pF
C1116	2113740F41	39pF
C1119	2113743E20	0.1uF
C1123	2113740F39	33pF
C1124	2113743E20	0.1uF
C1125	2113743E11	.039uF
C1126	2113743E20	0.1uF
C1127	2311049A57	10uF

Circuit Ref	Motorola Part No.	Description
C1128	2113743E20	0.1uF
C1129	2113740F35	22pF
C1130	2113740F47	68pF
C1133	2113743E20	0.1uF
C1134	2113743E20	0.1uF
C1135	2113743E20	0.1uF
C1136	2113743E20	0.1uF
C1137	2113740F53	120pF
C1138	2113743E20	0.1uF
C1139	2113741F49	.01uF
C1140	2113741F49	.01uF
C1141	2113743E20	0.1uF
C1142	2113743E20	0.1uF
C1143	2113743E20	0.1uF
C1144	2113743E20	0.1uF
C1145	2113741F41	4700pF
C1146	2113740F49	82pF
C1147	2113740F65	390pF
C1148	2113743E20	0.1uF
C1149	2113740F53	120pF
C1150	2113740F54	130pF
C1201	2113743E20	0.1uF
C1202	2311049J11	4.7uF
C1203	2113741F49	.01uF
C1204	2113740F59	220pF
C1206	2113740L37	62pF
C1207	2113740F07	1.5pF
C1209	2311049A57	10uF
C1210	2113743E20	0.1uF
C1211	2113741F49	.01uF
C1212	2311049A07	1uF
C1213	2113743A23	0.22uF
C1214	2113743E10	.033uF
C1215	2113740C37	6800pF
C1216	2311049J11	4.7uF
C1217	2113741F49	.01uF
C1218	2113743E20	0.1uF
C1219	2311049J11	4.7uF
C1220	2311049J11	4.7uF
C1222	2113740F40	36pF
C1223	2113741F49	.01uF
C1224	2113740F49	82pF
C1225	2113741F49	.01uF
C1227	2113741F49	.01uF
C1229	2113741F49	.01uF
C1230	2113741F49	.01uF
C1231	2113741F49	.01uF
C1250	2311049A09	2.2uF
C1251	2113743E20	0.1uF
C1252	2113743E05	.018uF
C1253	2311049J11	4.7uF
C1254	2113741F49	.01uF
C1306	2113740L23	16pF
C1307	2113740L21	13pF
C1308	2113740F19	4.7pF
C1311	2113741F49	.01uF

Circuit Ref	Motorola Part No.	Description
C1312	2113741F49	.01uF
C1313	2113741F49	.01uF
C1314	2113740L21	13pF
C1315	2113740L21	13pF
C1316	2113740F15	3.3pF
C1317	2113743E20	0.1uF
C1318	2113741F49	.01uF
C1319	2113741F49	.01uF
C1320	2113741F49	.01uF
C1321	2113740F17	3.9pF
C1323	2113740L21	13pF
C1325	2113741F49	.01uF
C1326	2113741F49	.01uF
C1333	2113740L26	22pF
C1334	2113740L31	36pF
C1335	2113740F19	4.7pF
C1336	2113743E20	0.1uF
C1338	2113741F49	.01uF
C1339	2113741F49	.01uF
C1340	2113741F49	.01uF
C1341	2113740L31	36pF
C1342	2113740L31	36pF
C1343	2113740F15	3.3pF
C1344	2113741F49	.01uF
C1345	2113743E20	0.1uF
C1346	2113741F49	.01uF
C1347	2113741F49	.01uF
C1348	2113740F17	3.9pF
C1349	2113743E20	0.1uF
C1350	2113740F31	15pF
C1351	2113741F49	.01uF
C1352	2113741F49	.01uF
C1401	2113741A45	.01uF
C1402	2113741A45	.01uF
C1404	2113741A45	.01uF
C1405	2113741A45	.01uF
C1407	2113741A45	.01uF
C1410	2113741M69	0.1uF
C1412	2113740A65	270pF
C1413	2113741A45	.01uF
C1414	2113741A45	.01uF
C1415	2113741M69	0.1uF
C1417	2111078B58	430pF
C1419	2113741A45	.01uF
C1420	2113741A45	.01uF
C1423	2113741A45	.01uF
C1424	2113741A45	.01uF
C1425	2113741W01	1uF
C1426	2113741W01	1uF
C1427	2111078B52	240pF
C1428	2111078B52	240pF
C1429	2111078B52	240pF
C1430	2111078B52	240pF
C1431	2113741A45	.01uF
C1432	2113741W01	1uF
C1433	2113741W01	1uF

Circuit Ref	Motorola Part No.	Description
C1434	2113741A45	.01uF
C1435	2113741W01	1uF
C1436	2113741A45	.01uF
C1437	2111078B59	470pF
C1438	2111078B59	470pF
C1439	2111078B59	470pF
C1440	2111078B59	470pF
C1441	2111078B51	220pF
C1442	2111078B44	120pF
C1443	2111078B45	130pF
C1444	2111078B45	130pF
C1446	2180060M28	24pF
C1447	2111078B59	470pF
C1448	2111078B59	470pF
C1449	2180060M44	110pF
C1450	2180060M05	3pF
C1451	2180060M49	180pF
C1452	2180060M28	24pF
C1453	2180060M43	100pF
C1454	2180060M31	33pF
C1455	2180060M24	16pF
C1456	2180060M36	51pF
C1457	2113741A45	.01uF
C1458	2311049C01	10uF
C1459	2311049C01	10uF
C1460	2113743E20	0.1uF
C1461	2113741A45	.01uF
C1462	2311049C01	10uF
C1463	2113928E01	1uF
C1464	2113741A45	.01uF
C1465	2113928E01	1uF
C1466	2113741A45	.01uF
C1467	2113740A51	68pF
C1468	2113741A45	.01uF
C1469	2113741W01	1uF
C1470	2113741W01	1uF
C1471	2113741A45	.01uF
C1472	2113741M69	0.1uF
C1473	2113741M69	0.1uF
C1474	2113741A45	.01uF
C1475	2113741W01	1uF
C1476	2113741M69	0.1uF
C1477	2111078B54	300pF
C1478	2111078B54	300pF
C1479	2111078B51	220pF
C1480	2111078B40	82pF
C1481	2111078B40	82pF
C1482	2113928E01	1uF
C1484	2113741F33	2200pF
C1485	2113741A45	.01uF
C1486	2113741M69	0.1uF
C1501	2113741F33	2200pF
C1502	2113741F33	2200pF
C1503	2113741F33	2200pF
C1504	2113741F33	2200pF
C1505	2113741F25	1000pF

Circuit Ref	Motorola Part No.	Description
C1506	2113741F25	1000pF
C1507	2113741F33	2200pF
C1508	2113741F33	2200pF
C1509	2311049A07	1uF
C1510	2113741F33	2200pF
C1511	2113741F33	2200pF
C1512	2113741F33	2200pF
C1523	2113743E20	0.1uF
C1525	2113743E20	0.1uF
C1526	2113740F51	100pF
C1527	2113741A45	.01uF
C1528	2113741A45	.01uF
C1530	2113741A45	.01uF
C1532	2113743T19	10uF
C1601	2113743E20	0.1uF
C1602	2113740F59	220pF
C1603	2113743A23	0.22uF
C1604	2113743A23	0.22uF
C1605	2311049A57	10uF
C1606	2113740F59	220pF
C1607	2113740F51	100pF
C1608	2113743A23	0.22uF
C1609	2113740F34	20pF
C1610	2113741F41	4700pF
C1611	2113743E20	0.1uF
C1612	2113741F33	2200pF
C1613	2113740F54	130pF
C1614	2113741F24	910pF
C1616	2113740F40	36pF
C1618	2113743A23	0.22uF
C1619	2311049A57	10uF
C1620	2113741F25	1000pF
C1622	2113743E20	0.1uF
C1623	2113740F60	240pF
C1624	2113741F37	3300pF
C1625	2113740F29	12pF
C1626	2113740F59	220pF
C1627	2113743A23	0.22uF
C1628	2113743E20	0.1uF
C1629	2113740F39	33pF
C1631	2311049A57	10uF
C1632	2113743E20	0.1uF
C1633	2113743A23	0.22uF
C1634	2113741A45	.01uF
CR1201	4802245J22	1T363
CR1202	4802233J09	IMN10
CR1302	4805649Q14	HN1V02H
CR1306	4880154K03	MMBD353
CR1310	4805649Q14	HN1V02H
CR1314	4880154K03	MMBD353
D1001	4880154K03	MMBD353
D1101	4880154K03	MMBD353
D1401	4808379X02	MA4P1450
D1402	4808379X02	MA4P1450
D1501	4880236E05	MMBD301
D1502	4813833C02	MMBD6100

Circuit Ref	Motorola Part No.	Description
D1503	4813833C02	MMBD6100
D1601	4880154K03	MMBD353
E1401	2408380X02	FERRITE BEAD
E1403	2408380X02	FERRITE BEAD
FL1101	9180656U03	CFEC10_7MG1
FL1102	9180022M09	CRYSTAL FILTER, 10.7 MHZ
FL1104	9180468V04	CFUCJ455F
FL1105	9180468V05	CFUCJ455E
FL1106	9180469V04	CFWC455F
FL1107	9180469V05	CFWC455E
J1401	0986166B02	MINI-U ANTENNA CONN
L1001	2408382A11	130nH
L1002	2408382C11	130nH
L1003	2408382A11	130nH
L1004	2408382C11	130nH
L1005	2408382A11	130nH
L1006	2408382A11	130nH
L1007	2408382C11	130nH
L1008	2408382A11	130nH
L1009	2408382C11	130nH
L1010	2408382A11	130nH
L1011	2462587N68	1uH
L1012	2462587N57	220nH
L1013	2462587N59	330nH
L1014	2462587N57	220nH
L1101	2462587N33	1.8uH
L1102	2408383X07	3.3uH
L1103	2462587N33	1.8uH
L1104	2480289M10	6.8uH
L1105	2480289M10	6.8uH
L1106	2462587N33	1.8uH
L1107	2480289M09	5.6uH
L1110	2480289M18	33uH
L1111	2408383X07	3.3uH
L1112	2483411T35	6.8uH
L1201	2480289M17	27uH
L1202	2462587Q20	2.2uH
L1205	2462587N59	330nH
L1206	2480289M17	27uH
L1302	2408382D19	491nH
L1303	2480289M15	18uH
L1304	2462587N66	820nH
L1305	2480289M15	18uH
L1306	2480289M15	18uH
L1307	2480289M15	18uH
L1309	2480289M15	18uH
L1310	2462587N60	390nH
L1311	2480289M15	18uH
L1313	2408382D19	491nH
L1314	2480289M17	27uH
L1315	2462587N66	820nH
L1316	2480289M17	27uH
L1317	2480289M17	27uH
L1318	2480289M17	27uH
L1321	2462587N58	270nH
L1322	2480289M17	27uH

Circuit Ref	Motorola Part No.	Description
L1324	2480289M17	27uH
L1402	2462587U09	4.7uH
L1403	2462587U09	4.7uH
L1404	2462587N56	180nH
L1406	2408381X36	250.974nH
L1408	2408384A10	120nH
L1413	2408381X17	88.470nH
L1414	2408381X17	88.470nH
L1415	2460591X01	18nH
L1416	2460591X01	18nH
L1417	2460591X01	18nH
L1418	2408381X12	66.389nH
L1419	2480289M17	27uH
L1420	2408381X29	172.891nH
L1421	2408381X25	137.876nH
L1422	2408381X22	115.581nH
L1423	2408381X16	81.930nH
L1425	2460591X01	18nH
L1426	2460591X01	18nH
L1601	2483411T45	47uH
L1602	2483411T45	47uH
L1603	2483411T73	1uH
L1604	2483411T45	47uH
L1605	2483411T41	22uH
L1606	2462587T30	1uH
L1607	2462587T30	1uH
M1401	2686201B01	HEATSINK
Q1001	4880173R01	MMBR951
Q1002	4813824A17	MMBT3906
Q1003	4813824A17	MMBT3906
Q1101	4813827A07	MMBR941
Q1102	4813823A05	MMBFU310L
Q1103	4813823A05	MMBFU310L
Q1104	4813823A05	MMBFU310L
Q1105	4880048M01	DTC144EKA
Q1106	4813827A07	MMBR941
Q1201	4813824A17	MMBT3906
Q1202	4880173R01	MMBR951
Q1303	4884235R02	MMBFU310
Q1304	4880173R01	MMBR951
Q1305	4880173R01	MMBR951
Q1306	4884235R02	MMBFU310
Q1307	4880173R01	MMBR951
Q1308	4880173R01	MMBR951
Q1401	4886212B01	MRF1518
Q1402	4886136B01	MRF1550
Q1403	4886136B01	MRF1550
Q1501	4880141L03	BCW68G
Q1502	4813824A10	MMBT3904
Q1503	4813824A10	MMBT3904
Q1504	4813824A10	MMBT3904
Q1505	4813824A17	MMBT3906
Q1506	4813824A10	MMBT3904
Q1601	4813824A17	MMBT3906
Q1602	4880048M01	DTC144EKA
Q1603	4813824A10	MMBT3904

Circuit Ref	Motorola Part No.	Description
Q1604	4813824A10	MMBT3904
Q1605	4813824A10	MMBT3904
Q1606	4813824A17	MMBT3906
Q1607	4813824A10	MMBT3904
Q1609	4813824A17	MMBT3906
Q1610	4805585Q17	NE25139
R1001	0662057A05	15
R1002	0662057A05	15
R1003	0662057A41	470
R1004	0662057A59	2.7K
R1005	0662057A31	180
R1006	0662057A73	10K
R1007	0662057A71	8.2K
R1008	0662057A65	4.7K
R1101	0662057A18	51
R1102	0662057A78	16K
R1103	0662057A39	390
R1104	0662057A71	8.2K
R1106	0662057A25	100
R1107	0662057A68	6.2K
R1108	0662057A61	3.3K
R1109	0662057A37	330
R1110	0662057A25	100
R1111	0662057A17	47
R1113	0662057A64	4.3K
R1114	0662057A64	4.3K
R1115	0662057A75	12K
R1117	0662057A37	330
R1118	0662057A56	2K
R1119	0662057A83	27K
R1120	0662057A18	51
R1121	0662057A71	8.2K
R1122	0662057A73	10K
R1123	0662057A51	1.2K
R1128	0662057A73	10K
R1129	0662057A73	10K
R1130	0662057A73	10K
R1131	0662057A77	15K
R1132	0662057A58	2.4K
R1133	0662057A61	3.3K
R1134	0662057A05	15
R1135	0662057A20	62
R1136	0662057A45	680
R1137	0662057A75	12K
R1138	0662057A01	10
R1139	0611077A12	2.7
R1201	0662057B47	0
R1202	NOTPLACED	
R1203	0662057B02	150K
R1204	0662057B47	0
R1205	0662057A45	680
R1206	0662057A41	470
R1208	0662057A18	51
R1209	0662057A61	3.3K
R1210	0662057A33	220
R1211	0662057B14	470K

Circuit Ref	Motorola Part No.	Description
R1212	0662057A25	100
R1213	0662057A45	680
R1214	0662057A54	1.6K
R1215	0662057A21	68
R1216	0662057A18	51
R1217	0662057A25	100
R1218	0662057A17	47
R1219	0662057A17	47
R1220	0662057A17	47
R1221	0662057B47	0
R1306	0662057B47	0
R1307	0662057A19	56
R1308	0662057A19	56
R1309	0662057A41	470
R1311	0662057A73	10K
R1312	0662057A51	1.2K
R1313	0662057A51	1.2K
R1314	0662057A37	330
R1315	0662057A61	3.3K
R1316	0662057A45	680
R1317	0662057A09	22
R1318	0662057A41	470
R1319	0662057A01	10
R1320	0662057A41	470
R1325	0662057B47	0
R1326	0662057A19	56
R1327	0662057A19	56
R1328	0662057A41	470
R1330	0662057A73	10K
R1331	0662057A51	1.2K
R1332	0662057A51	1.2K
R1333	0662057A37	330
R1334	0662057A61	3.3K
R1335	0662057A47	820
R1336	0662057A09	22
R1337	0662057A22	75
R1338	0662057A27	120
R1339	0662057A22	75
R1340	0662057A49	1K
R1341	0662057A25	100
R1342	0662057A25	100
R1343	0662057C55	150
R1344	0662057A49	1K
R1345	0662057A25	100
R1346	0662057A25	100
R1347	0662057C55	150
R1376	0662057A65	4.7K
R1402	0611079A64	390
R1404	0680194M18	51
R1405	0680194M18	51
R1406	0662057A73	10K
R1407	0662057A73	10K
R1409	0682089V01	.01
R1410	0683962T52	130
R1411	0662057C99	10K
R1413	0680194M01	10

Circuit Ref	Motorola Part No.	Description
R1414	0680194M01	10
R1416	0680194M01	10
R1417	0680194M01	10
R1418	0680194M01	10
R1419	0680194M01	10
R1420	0680194M01	10
R1421	0680194M01	10
R1422	0680194M01	10
R1423	0680194M01	10
R1424	0662057D10	27K
R1425	0662057D10	27K
R1440	0662057A25	100
R1442	0662057A25	100
R1443	0662057A49	1K
R1444	0662057A33	220
R1445	0662057A68	6.2K
R1447	0662057B47	0
R1449	0611079A64	390
R1450	0683962T71	820
R1451	0662057K31	180
R1453	0662057K31	180
R1454	0662057K31	180
R1455	0662057K31	180
R1457	0662057K01	10
R1458	0611079A64	390
R1459	0611079A64	390
R1460	0680106R01	0.1
R1463	0662057A75	12K
R1464	0662057A61	3.3K
R1465	0662057A61	3.3K
R1469	0662057C01	0
R1472	0662057A73	10K
R1473	0680194M01	10
R1474	0680194M01	10
R1475	0680194M01	10
R1476	0680194M01	10
R1477	0662057A61	3.3K
R1478	0662057A73	10K
R1479	0662057A61	3.3K
R1480	0662057D10	27K
R1482	0662057B47	0
R1483	0662057A34	240
R1484	0662057A49	1K
R1501	0662057A45	680
R1502	0662057C67	470
R1503	0662057A61	3.3K
R1504	0662057A73	10K
R1505	0662057A69	6.8K
R1506	0662057A87	39K
R1507	0662057A49	1K
R1508	0662057R19	100
R1509	0662057P95	100K
R1511	0662057P95	100K
R1513	0662057C76	1.1K
R1514	0662057A97	100K
R1515	0662057A49	1K

Circuit Ref	Motorola Part No.	Description
R1516	0662057C71	680
R1517	0662057C71	680
R1518	0662057A61	3.3K
R1519	0662057C71	680
R1522	0662057A73	10K
R1524	0662057C71	680
R1526	0662057A97	100K
R1527	0662057A97	100K
R1528	0662057A80	20K
R1532	0662057A95	82K
R1533	0662057A73	10K
R1535	0662057C01	0
R1537	0662057A90	51K
R1541	0662057A68	6.2K
R1542	0662057A49	1K
R1543	0662057A49	1K
R1544	0662057A90	51K
R1545	0662057A65	4.7K
R1601	0662057A73	10K
R1602	0662057A65	4.7K
R1604	0662057A49	1K
R1605	0662057B10	330K
R1606	0662057B02	150K
R1607	0662057B19	750K
R1608	0662057A57	2.2K
R1609	0662057A73	10K
R1610	0662057A82	24K
R1611	0662057A49	1K
R1612	0662057A25	100
R1613	0662057A59	2.7K
R1614	0662057A49	1K
R1615	0662057A49	1K
R1616	0662057A33	220
R1617	0662057A57	2.2K
R1620	0662057A51	1.2K
R1621	0662057A68	6.2K
R1622	0662057A49	1K
R1626	0662057A18	51
R1627	0662057A73	10K
R1628	0662057A55	1.8K
R1629	0662057A67	5.6K
R1630	0662057A53	1.5K
R1631	0662057A18	51
R1632	0662057A82	24K
R1635	0662057B47	0
R1636	0662057A42	510
R1637	0662057A59	2.7K
R1638	0662057A55	1.8K
SH1302	2680473U01	VCO SHIELD
U1001	4802245J50	UMC5N
U1051	5108278X01	MIXER
U1101	5113805A86	MC74HC4066
U1102	5113805A86	MC74HC4066
U1103	5186144B01	SA616
U1201	5185963A27	FRACN SYNTHESIZER
U1250	5185963A33	LP2951

Circuit Ref	Motorola Part No.	Description
U1377	4802245J50	UMC5N
U1378	4802245J50	UMC5N
U1401	5185130C65	LDMOS PREDRIVER IC
U1402	5113818A03	MC33072
U1501	5185963A15	LM50
U1502	5109731C21	LM6142BIM
U1503	5185765B28	POWER CONTROL IC
U1601	5180929W01	MC1350
Y1101	4880908W08	CRYSTAL, 10.245 MHZ
Y1102	9186145B02	DISCRIMINATOR, 455 KHZ
Y1201	4880114R04	CRYSTAL, 16.8 MHZ
Y1202	NOTPLACED	

* Motorola Depot Servicing only
 Reference designators with an asterisk indicate components which are not fieldreplaceable because they need to be calibrated with specialized factory equipment after installation. Radios in which these parts have been replaced in the field will be off frequency at temperature extremes.



Professional Radio

GM Series

UHF (403-470MHz)

Service Information

Computer Software Copyrights

The Motorola products described in this manual may include copyrighted Motorola computer programs stored in semiconductor memories or other media. Laws in the United States and other countries preserve for Motorola certain exclusive rights for copyrighted computer programs, including the exclusive right to copy or reproduce in any form, the copyrighted computer program. Accordingly, any copyrighted Motorola computer programs contained in the Motorola products described in this manual may not be copied or reproduced in any manner without the express written permission of Motorola. Furthermore, the purchase of Motorola products shall not be deemed to grant, either directly or by implication, estoppel or otherwise, any license under the copyrights, patents or patent applications of Motorola, except for the normal non-exclusive royalty-free license to use that arises by operation of law in the sale of a product.

Table of Contents

Chapter 1 MODEL CHART AND TECHNICAL SPECIFICATIONS

1.0 GM140/GM160 Model Chart.....	1-1
2.0 GM340/GM360/GM380 Model Chart.....	1-1
3.0 GM640/GM660/GM1280 Model Chart.....	1-2
4.0 Technical Specifications	1-3

Chapter 2 THEORY OF OPERATION

1.0 Introduction	2-1
2.0 UHF (403-470MHz) Receiver	2-1
2.1 Receiver Front-End	2-1
2.2 Front-End Band-Pass Filters & Pre-Amplifier	2-2
2.3 First Mixer and High Intermediate Frequency (IF).....	2-2
2.4 Low Intermediate Frequency (IF) and Receiver Back End.....	2-2
3.0 UHF (403-470MHz) Transmitter Power Amplifier (PA) 25 W.....	2-3
3.1 First Power Controlled Stage.....	2-3
3.2 Power Controlled Driver Stage	2-4
3.3 Final Stage	2-4
3.4 Directional Coupler.....	2-4
3.5 Antenna Switch.....	2-5
3.6 Harmonic Filter	2-5
3.7 Power Control	2-5
4.0 UHF (403-470MHz) Frequency Synthesis	2-6
4.1 Reference Oscillator	2-6
4.2 Fractional-N Synthesizer	2-6
4.3 Voltage Controlled Oscillator (VCO).....	2-7
4.4 Synthesizer Operation	2-8
5.0 UHF (403-470MHz) Transmitter Power Amplifier (PA) 40 W.....	2-9
5.1 Power Controlled Stage.....	2-9
5.2 Pre-Driver Stage.....	2-9
5.3 Driver Stage.....	2-10
5.4 Final Stage	2-10
5.5 Directional Coupler.....	2-10
5.6 Antenna Switch.....	2-10
5.7 Harmonic Filter	2-10
5.8 Power Control	2-11

Chapter 3 TROUBLESHOOTING CHARTS

1.0	Troubleshooting Flow Chart for Receiver (Sheet 1 of 2)	3-1
1.1	Troubleshooting Flow Chart for Receiver (Sheet 2 of 2)	3-2
2.0	Troubleshooting Flow Chart for 25W Transmitter (Sheet 1 of 3)	3-3
2.1	Troubleshooting Flow Chart for 25W Transmitter (Sheet 2 of 3)	3-4
2.2	Troubleshooting Flow Chart for 25W Transmitter (Sheet 3 of 3)	3-5
3.0	Troubleshooting Flow Chart for 40W Transmitter	3-6
4.0	Troubleshooting Flow Chart for Synthesizer.....	3-7
5.0	Troubleshooting Flow Chart for VCO.....	3-8

Chapter 4 UHF PCB/SCHEMATICS/PARTS LISTS

1.0	Allocation of Schematics and Circuit Boards	4-1
1.1	Controller Circuits	4-1
2.0	UHF 1-25W PCB 8485670z02 / Schematics	4-3
2.1	UHF 1-25W PCB 8485670z02 Parts List.....	4-10
3.0	UHF 25-40W PCB 8480643z06 / Schematics	4-13
3.1	UHF 25-40W PCB 8480643z06 Parts List.....	4-20
4.0	UHF 1-25W PCB 8485670z03 / Schematics	4-23
4.1	UHF 1-25W PCB 8485670z03 Parts List.....	4-30

Chapter 1

MODEL CHART AND TECHNICAL SPECIFICATIONS

1.0 GM140/GM160 Model Chart

GM Series UHF 403-470 MHz			
Model		Description	
MDM25RKC9AA1_E		GM140, 403-470 MHz, 25-40W, 4 Ch	
MDM25RKF9AA5_E		GM160, 403-470 MHz, 25-40W, 128 Ch	
	Item	Description	
X		GCN6112_	Control Head GM140
	X	GCN6114_	Control Head GM160
X		IMUE6024_S	Field Replaceable Unit (Main Board) GM140
	X	IMUE6024_S	Field Replaceable Unit (Main Board) GM160
X	X	ENBN4056_	Packaging, Waris Mobile Radio
X	X	GLN7324_	Low Profile Mounting Trunnion
X	X	HKN9402_	12V Power Cable, 25-45W
X	X	MDRMN4025_	Enhanced Compact Microphone
X		6864110B86	User Guide, GM140
	X	6864110B87	User Guide, GM160
X = Indicates one of each is required			

2.0 GM340/GM360/GM380 Model Chart

GM Series UHF 403-470 MHz					
Model				Description	
MDM25RHC9AN1_E				GM340, 403-470 MHz, 1-25W, 6 Ch	
MDM25RHF9AN5_E				GM360, 403-470 MHz, 1-25W, 255 Ch	
MDM25RHC9AN8_E				GM380, 403-470 MHz, 1-25W, 255 Ch	
MDM25RHA9AN0_E				Databox, 403-470 MHz, 1-25W, 16 Ch	
Item				Description	
X				GCN6112_	Control Head GM340
	X			GCN6120_	Control Head GM360
		X		GCN6121_	Control Head GM380
			X	GCN6116_	Databox Radio Blank Head
X				IMUE6015_S	Field Replaceable Unit (Main Board) GM340
	X			IMUE6015_S	Field Replaceable Unit (Main Board) GM360
		X		IMUE6038_S	Field Replaceable Unit (Main Board) GM380
			X	IMUE6015_A	S/T 403-470MHz 1-25 SEL5
X	X	X	X	ENBN4056_	Packaging, Waris Mobile
X	X	X	X	GLN7324_	Low Profile Mounting Trunnion
X	X	X	X	HKN4137_	12V Power Cable 1-25W
X	X	X		MDRMN4025_	Enhanced Compact Microphone
X				6864110B80	User Guide GM340
	X			6864110B81	User Guide, GM360
		X		6864110B82	User Guide, GM380

X = Indicates one of each is required

3.0 GM640/GM660/GM1280 Model Chart

GM Series UHF 403-470 MHz				
Model				Description
	MDM25RHC9CK1_E			GM640, 403-470 MHz, 1-25W, 6 Ch
	MDM25RHF9CK5_E			GM660, 403-470 MHz, 1-25W, 255 Ch
	MDM25RHN9CK8_E			GM1280, 403-470 MHz, 1-25W, 255 Ch
	MDM25RHA9CK7_E			Databox, 403-470 MHz, 1-25W, 16 Ch
			Item	Description
X			GCN6112_	Control Head GM640
	X		GCN6120_	Control Head GM660
		X	GCN6121_	Control Head GM1280
			X GCN6116_	Databox Radio Blank Head
			X IMUE6009_A	S/T 403-470MHz 1-25 SEL5
X			IMUE6009_S	Field Replaceable Unit (Main Board) GM640
	X		IMUE6009_S	Field Replaceable Unit (Main Board) GM660
		X	IMUE6009_S	Field Replaceable Unit (Main Board) GM1280
X	X	X	X ENBN4056_	Packaging, Waris Mobile Radio
X	X	X	X GLN7324_	Low Profile Mounting Trunnion
X	X	X	X HKN4137_	12V Power Cable, 1-25W
X	X	X	MDRMN4025_	Enhanced Compact Microphone
X			6864110B83_	User Guide, GM640
	X		6864110B84_	User Guide, GM660
		X	6864110B85_	User Guide, GM1280

X = Indicates one of each is required

4.0 Technical Specifications

Data is specified for +25°C unless otherwise stated.

General Specifications	
Channel Capacity	
GM140	4
GM160	128
GM340	6
GM360	255
GM380	255
GM640	6
GM660	255
GM1280	255
Databox	16
Power Supply	13.2Vdc (10.8 - 15.6Vdc)
Dimensions: H x W x D (mm) Depth excluding knobs	GM140/340/640 56mm x 176mm x 177mm (1 - 25W) 56mm x 176mm x 189mm (25 - 40W) (add 8mm for Volume Knob)
Dimensions: H x W x D (mm) Depth excluding knobs	GM160/360/660 59mm x 179mm x 186mm (1 - 25W) 59mm x 179mm x 198mm (25 - 40W) (add 9mm for Volume Knob)
Dimensions: H x W x D (mm) Depth excluding knobs	GM380/1280 72mm x 185mm x 188mm (add 8mm for Volume Knob)
Dimensions: H x W x D (mm) Depth excluding knobs	Databox 44mm x 168mm x 161mm
Weight GM140/340/640	1400gr
Weight GM160/360/660	1400gr
Weight GM380/1280	1500gr
Weight Databox	1220gr
Sealing:	Withstands rain testing per MIL STD 810 C/D /E and IP54
Shock and Vibration:	Protection provided via impact resistant housing exceeding MIL STD 810-C/D /E and TIA/EIA 603
Dust and Humidity:	Protection provided via environment resistant housing exceeding MIL STD 810 C/D /E and TIA/EIA 603

Transmitter	UHF
*Frequencies - Full Bandsplit	UHF 403-470 MHz
Channel Spacing	12.5/20/25 kHz
Frequency Stability (-30°C to +60°C, +25° Ref.)	±2.0 ppm
Power	1-25W/25-40W
Modulation Limiting	±2.5 @ 12.5 kHz ±4.0 @ 20 kHz ±5.0 @ 25 kHz
FM Hum & Noise	-40 dB @ 12.5kHz -45 dB @ 20/25kHz
Conducted/Radiated Emission (ETS)	-36 dBm <1 GHz -30 dBm >1 GHz
Adjacent Channel Power	-60 dB @ 12.5 kHz -70 dB @ 25 kHz
Audio Response (300 - 3000 Hz)	+1 to -3 dB
Audio Distortion @1000Hz, 60% Rated Maximum Deviation	<3% typical

Receiver	UHF
*Frequencies - Full Bandsplit	UHF 403-470 MHz
Channel Spacing	12.5/20/25 kHz
Sensitivity (12 dB SINAD)	0.30 µV (0.22 µV typical)
Intermodulation (ETS)	>65 dB Base Mode: >70dB (1-25W model only)
Adjacent Channel Selectivity (ETS)	65 dB @ 12.5 kHz 70 dB @ 20 kHz 75 dB @ 25 kHz
Spurious Rejection (ETS)	70 dB @ 12.5 kHz 75 dB @ 20/25 kHz
Rated Audio	3W Internal 13W External
Audio Distortion @ Rated Audio	<3% typical
Hum & Noise	-40 dB @ 12.5 kHz -45 dB @ 20/25 kHz
Audio Response (300 - 3000Hz @ 20/25kHz) (300 - 2550Hz @ 12.5kHz)	+1 to -3 dB
Conducted Spurious Emission (ETS)	-57 dBm <1 GHz -47 dBm >1 GHz

*Availability subject to the laws and regulations of individual countries.

THEORY OF OPERATION

1.0 Introduction

This Chapter provides a detailed theory of operation for the UHF circuits in the radio. For details of the theory of operation and trouble shooting for the the associated Controller circuits refer to the Controller Section of this manual.

2.0 UHF (403-470MHz) Receiver

2.1 Receiver Front-End

The receiver is able to cover the UHF range from 403 to 470 MHz. It consists of four major blocks: front-end bandpass filters and pre-amplifier, first mixer, high-IF, low-IF and receiver back-end . Two varactor-tuned bandpass filters perform antenna signal pre-selection. A cross over quad diode mixer converts the signal to the first IF of 44.85 MHz. Low-side first injection is used.

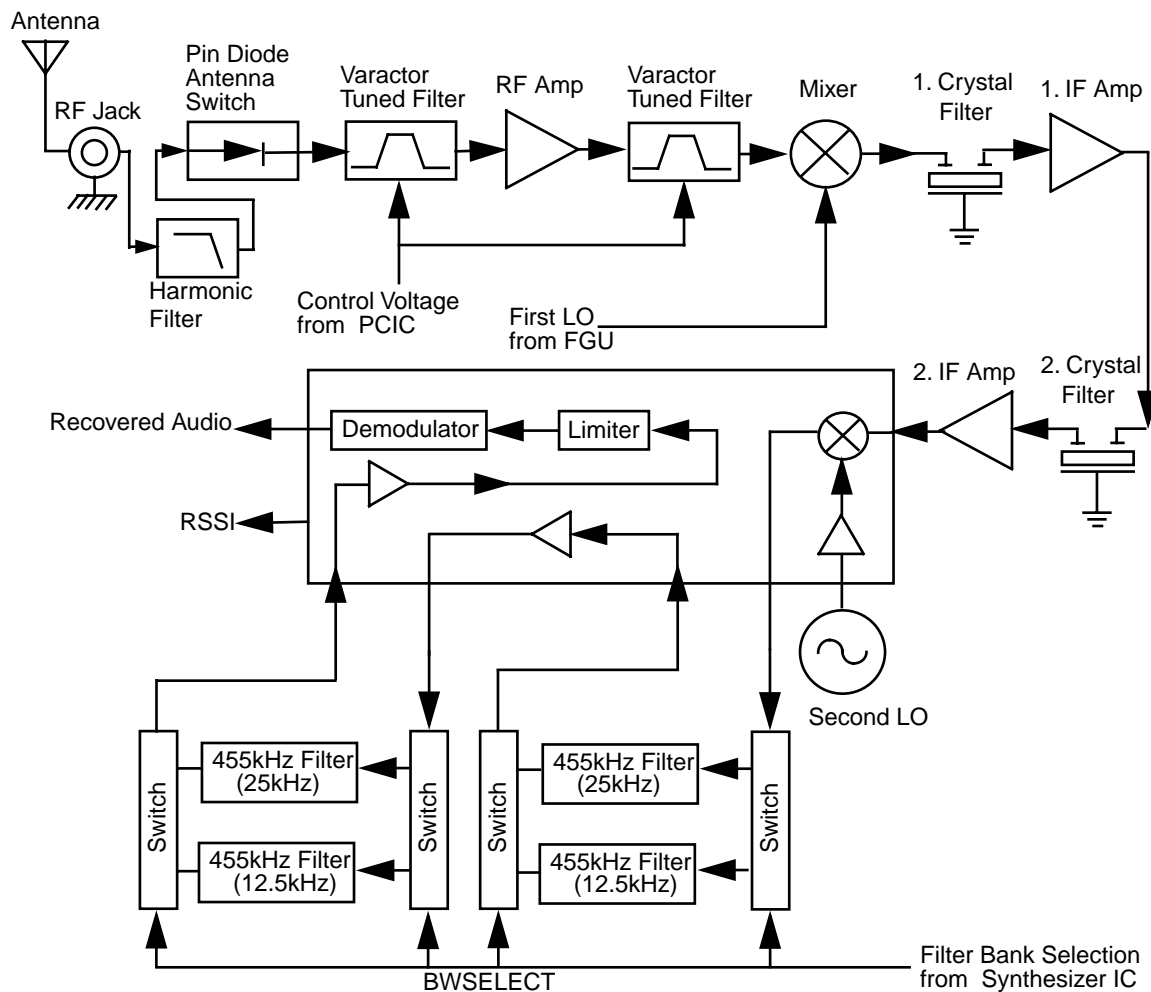

Figure 2-1 UHF Receiver Block Diagram

There are two 2-pole 44.85 MHz crystal filters in the high-IF section and 2 pairs of 455 kHz ceramic filters in the low-IF section to provide the required adjacent channel selectivity. The correct pair of ceramic filters for 12.5 or 25KHz channel spacing is selected via control line BWSELECT. The second IF at 455 kHz is mixed, amplified and demodulated in the IF IC. The processing of the demodulated audio signal is performed by an audio processing IC located in the controller section.

2.2 Front-End Band-Pass Filters & Pre-Amplifier

The received signal from the radio's antenna connector is first routed through the harmonic filter and antenna switch, which are part of the RF power amplifier circuitry, before being applied to the receiver pre-selector filter (C4001, C4002, D4001 and associated components). The 2-pole pre-selector filter tuned by the varactor diodes D4001 and D4002 pre-selects the incoming signal (RXIN) from the antenna switch to reduce spurious effects to following stages. The tuning voltage (FECTRL_1) ranging from 2 volts to 8 volts is controlled by pin 20 of PCIC (U4501) in the Transmitter section. A dual hot carrier diode (D4003) limits any inband signal to 0 dBm to prevent damage to the pre-amplifier.

The RF pre-amplifier is an SMD device (Q4003) with collector base feedback to stabilize gain, impedance, and intermodulation. The collector current of approximately 11-16 mA is drawn from the voltage 9V3 via L4003 and R4002. A switchable 3dB pad (R4066, R4007, R4063, R4064 and R4070), controlled via line FECTRL_2 and Q4004 stabilizes the output impedance and intermodulation performance.

A second 2-pole varactor tuned bandpass filter provides additional filtering of the amplified signal. The varactor diodes D4004 and D4005 are controlled by the same signal FECTRL_1, which controls the pre-selector filter. A following 1 dB pad (R4013 - R4015) stabilizes the output impedance and intermodulation performance.

2.3 First Mixer and High Intermediate Frequency (IF)

The signal coming from the front-end is converted to the first IF (44.85 MHz) using a cross over quad diode mixer (D4051). Its ports are matched for incoming RF signal conversion to the 44.85 MHz IF using low side injection via matching transformers T4051 and T4052. The injection signal (RXINJ) coming from the RX VCO buffer (Q4332) is filtered by the lowpass filter consisting of (L4053, L4054, C4053 - C4055) followed by a matching transformer T4052 and has a level of approximately 15dBm.

The mixer IF output signal (IF) from transformer T4501 pin 2 is fed to the first two pole crystal filter FL3101. The filter output in turn is matched to the following IF amplifier.

The IF amplifier Q3101 is actively biased by a collector base feedback (R3101, R3106) to a current drain of approximately 5 mA drawn from the voltage 5V. Its output impedance is matched to the second two pole crystal filter FL3102. The signal is further amplified by a preamplifier (Q3102) before going into pin 1 of IFIC (U3101).

A dual hot carrier diode (D3101) limits the filter output voltage swing to reduce overdrive effects at RF input levels above -27 dBm.

2.4 Low Intermediate Frequency (IF) and Receiver Back End

The 44.85 high IF signal from the second IF amplifier feeds the IF IC (U3101) at pin 1. Within the IF IC the 44.85 MHz high IF signal mixes with the 44.395 MHz second local oscillator (2nd LO) to

produce the low IF signal at 455 kHz. The 2nd LO frequency is determined by crystal Y3101. The low IF signal is amplified and filtered by an external pair of 455 kHz ceramic filters FL3112, FL3114 for 20/25 kHz channel spacing or FL3111,FL3113/F3115 for 12.5 kHz channel spacing. These pairs are selectable via BWSELECT. The filtered output from the ceramic filters is applied to the limiter input pin of the IF IC (pin 14).

The IF IC contains a quadrature detector using a ceramic phase-shift element (Y3102) to provide audio detection. Internal amplification provides an audio output level of 120 mV rms (at 60% deviation) from U3103 pin 8 (DISCAUDIO) which is fed to the ASFIC_CMP (U0221) pin 2 (part of the Controller circuitry).

A received signal strength indicator (RSSI) signal is available at U3101 pin 5, having a dynamic range of 70 dB. The RSSI signal is interpreted by the microprocessor (U0101 pin 63) and in addition is available at accessory connector J0501-15.

3.0 UHF (403-470MHz) Transmitter Power Amplifier (PA) 25 W

The radio's 25W PA is a three stage amplifier used to amplify the output from the VCOBIC to the radio transmit level. All three stages utilize LDMOS technology. The gain of the first stage (U4401) is adjustable, controlled by pin 4 of PCIC (U4501) via U4402-1. It is followed by an LDMOS stage (Q4421) and LDMOS final stage (Q4441).

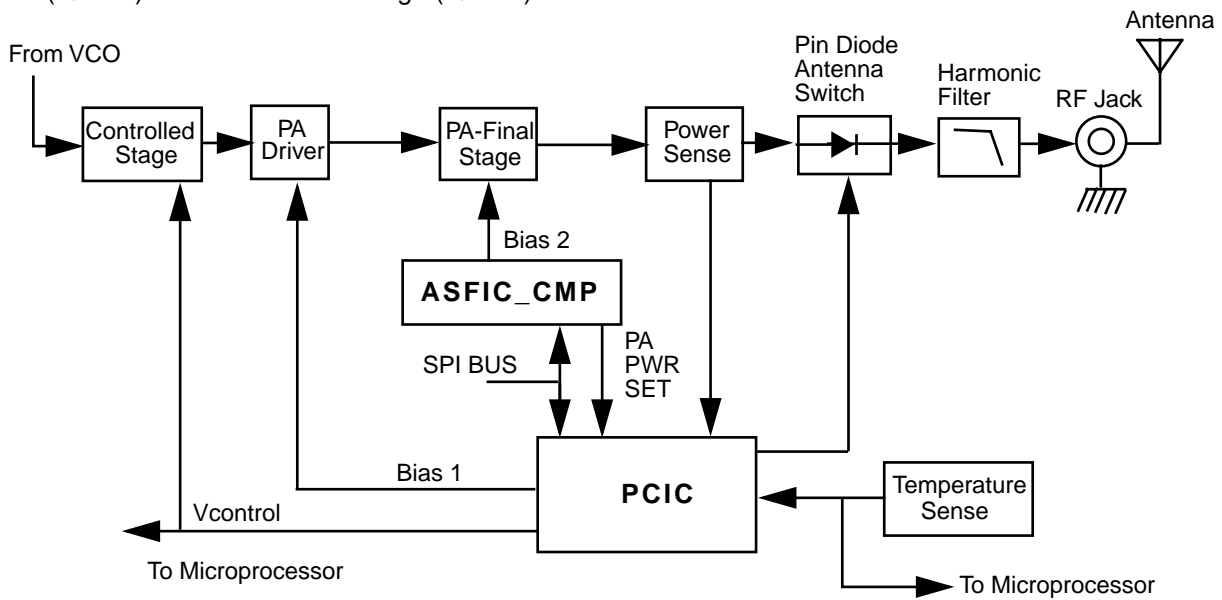

Figure 2-2 UHF Transmitter Block Diagram

Devices U4401, Q4421 and Q4441 are surface mounted. A pressure pad between board and the radio's cover provides good thermal contact between the devices and the chassis.

3.1 First Power Controlled Stage

The first stage (U4401) is a 20dB gain integrated circuit containing two LDMOS FET amplifier stages. It amplifies the RF signal from the VCO (TXINJ). The output power of stage U4401 is

controlled by a DC voltage applied to pin 1 from the op-amp U4402-1, pin 1. The control voltage simultaneously varies the bias of two FET stages within U4401. This biasing point determines the overall gain of U4401 and therefore its output drive level to Q4421, which in turn controls the output power of the PA.

Op-amp U4402-1 monitors the drain current of U4401 via resistor R4444 and adjusts the bias voltage of U4401 so that the current remains constant. The PCIC (U4501) provides a DC output voltage at pin 4 (INT) which sets the reference voltage of the current control loop. A raising power output causes the DC voltage from the PCIC to fall, and U4402-1 adjusts the bias voltage for a lower drain current to lower the gain of the stage.

In receive mode the DC voltage from PCIC pin 23 (RX) turns on Q4442, which in turn switches off the biasing voltage to U4401.

Switch S5440 is a pressure pad with a conductive strip which connects two conductive areas on the board when the radio's cover is properly screwed to the chassis. When the cover is removed, S5440 opens and the resulting high voltage level at the inverting inputs of the current control op-amps U4402-1 & 2 switches off the biasing of U4401 and Q4421. This prevents transmitter key up while the devices do not have proper thermal contact to the chassis.

3.2 Power Controlled Driver Stage

The next stage is an LDMOS device (Q4421) providing a gain of 12dB. This device requires a positive gate bias and a quiescent current flow for proper operation. The bias is set during transmit mode by the drain current control op-amp U4402-2, and fed to the gate of Q4421 via the resistive network R4429, R4418, R4415 and R4416.

Op-amp U4402-2 monitors the drain current of U4421 via resistors R4424-27 and adjusts the bias voltage of Q4421 so that the current remains constant. The PCIC (U4501) provides a DC output voltage at pin 4 (INT) which sets the reference voltage of the current control loop. A raising power output causes the DC voltage from the PCIC to fall, and U4402-2 adjusts the bias voltage for a lower drain current to lower the gain of the stage.

In receive mode the DC voltage from PCIC pin 23 (RX) turns on Q4422, which in turn switches off the biasing voltage to Q4421.

3.3 Final Stage

The final stage is an LDMOS device (Q4441) providing a gain of 12dB. This device also requires a positive gate bias and a quiescent current flow for proper operation. The voltage of the line MOSBIAS_2 is set in transmit mode by the ASFIC and fed to the gate of Q4441 via the resistive network R4404, R4406, and R4431-2. This bias voltage is tuned in the factory. If the transistor is replaced, the bias voltage must be tuned using the Golbal Tuner. Care must be taken not to damage the device by exceeding the maximum allowed bias voltage. The device's drain current is drawn directly from the radio's DC supply voltage input, PASUPVLTG, via L4436 and L4437. A matching network consisting of C4441-49 and striplines transforms the impedance to 50 ohms and feeds the directional coupler.

3.4 Directional Coupler

The directional coupler is a microstrip printed circuit, which couples a small amount of the forward power delivered by Q4441. The coupled signal is rectified by D4451. The DC voltage is proportional to the RF output power and feeds the RFIN port of the PCIC (U4501 pin 1). The PCIC controls the gain of stages U4401 and Q4421 as necessary to hold this voltage constant, thus ensuring the forward power out of the radio to be held to a constant value.

3.5 Antenna Switch

The antenna switch consists of two PIN diodes, D4471 and D4472. In the receive mode, both diodes are off. Signals applied at the antenna jack J4401 are routed, via the harmonic filter, through network L4472, C4474 and C4475, to the receiver input. In the transmit mode, K9V1 turns on Q4471 which enables current sink Q4472, set to 96 mA by R4473 and VR4471. This completes a DC path from PASUPVLTG, through L4437, D4471, L4472, D4472, L4471, R4474 and the current sink, to ground. Both diodes are forward biased into conduction. The transmitter RF from the directional coupler is routed via D4471 to the harmonic filter and antenna jack. D4472 also conducts, shunting RF power and preventing it from reaching the receiver port (RXIN). L4472 is selected to appear as a broadband $\lambda/4$ wave transmission line, making the short circuit presented by D4472 appear as an open circuit at the junction of D4472 and the receiver path.

3.6 Harmonic Filter

Components L4491-L4493 and L4472, C4491, C4496-98 form a Butterworth low-pass filter to attenuate harmonic energy of the transmitter to specifications level. R4491 is used to drain electrostatic charge that might otherwise build up on the antenna. The harmonic filter also prevents high level RF signals above the receiver passband from reaching the receiver circuits, improving spurious response rejection.

3.7 Power Control

The transmitter uses the Power Control IC (PCIC, U4501) to control the power output of the radio. A portion of the forward RF power from the transmitter is sampled by the directional coupler and rectified, to provide a DC voltage to the RFIN port of the PCIC (pin 1) which is proportional to the sampled RF power.

The ASFIC (U0221) has internal digital to analog converters (DACs) which provide a reference voltage of the control loop to the PCIC via R4505. The reference voltage level is programmable through the SPI line of the PCIC. This reference voltage is proportional to the desired power setting of the transmitter, and is factory programmed at several points across the frequency range of the transmitter to offset frequency response variations of the transmitter's power detector circuit.

The PCIC provides a DC output voltage at pin 4 (INT) which sets the drain current of the first (U4401) and second (Q4421) transmitter stage via current control op-amps U3402-1 and U3402-2. This adjusts the transmitter power output to the intended value. Variations in forward transmitter power cause the DC voltage at pin 1 to change, and the PCIC adjusts the control voltage above or below its nominal value to raise or lower output power.

Capacitors C4502-4, in conjunction with resistors and integrators within the PCIC, control the transmitter power-rise (key-up) and power-decay (de-key) characteristic to minimize splatter into adjacent channels.

U4502 is a temperature-sensing device, which monitors the circuit board temperature in the vicinity of the transmitter driver and final devices, and provides a dc voltage to the PCIC (TEMP, pin 30) proportional to temperature. If the DC voltage produced exceeds the set threshold in the PCIC, the transmitter output power will be reduced so as to reduce the transmitter temperature.

4.0 UHF (403-470MHz) Frequency Synthesis

The synthesizer subsystem consists of the reference oscillator (Y4261 or Y4262), the Low Voltage Fractional-N synthesizer (LVFRAC-N, U4201), and the Voltage Controlled Oscillator VCO.

4.1 Reference Oscillator

The reference oscillator (Y4262) contains a temperature compensated crystal oscillator with a frequency of 16.8 MHz. An Analogue to Digital (A/D) converter internal to U4201 (LVFRAC-N) and controlled by the microprocessor via serial interface (SRL) sets the voltage at the warp output of U4201 pin 25 to set the frequency of the oscillator. The output of the oscillator (pin 3 of Y4262) is applied to pin 23 (XTAL1) of U4201 via a RC series combination.

In applications where less frequency stability is required the oscillator inside U4201 is used along with an external crystal Y4261, varactor diode D4261, C4261, C4262 and R4262. In this case, Y4262, R4263, C4235 and C4251 are not used. When Y4262 is used, Y4261, D4261, C4261, C4262 and R4262 are not used, and C4263 is increased to 0.1 uF.

4.2 Fractional-N Synthesizer

The LVFRAC-N synthesizer IC (U4201) consists of a pre-scaler, a programmable loop divider, control divider logic, a phase detector, a charge pump, an A/D converter for low frequency digital modulation, a balance attenuator to balance the high frequency analogue modulation and low frequency digital modulation, a 13V positive voltage multiplier, a serial interface for control, and finally a super filter for the regulated 5 volts.

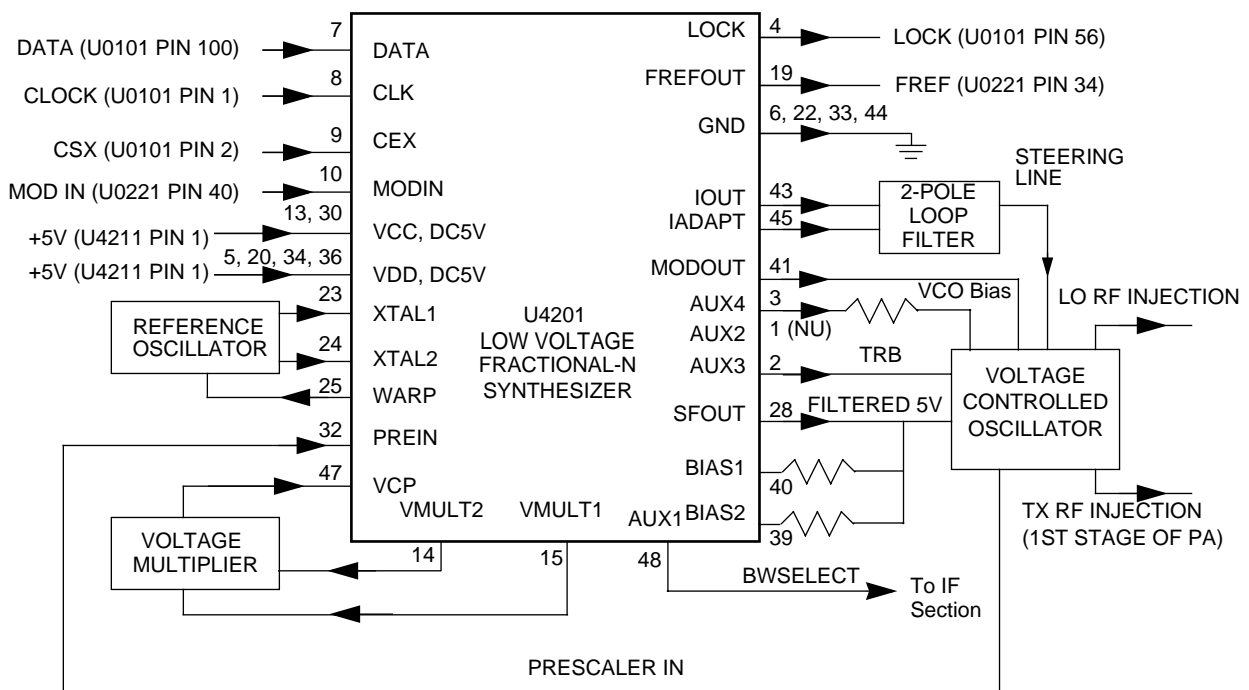

Figure 2-3 UHF Synthesizer Block Diagram

A voltage of 5V applied to the super filter input (U4201 pin 30) supplies an output voltage of 4.5 VDC(VSF) at pin 28. It supplies the VCO, VCO modulation bias circuit (via R4322) and the synthesizer charge pump resistor network (R4251, R4252). The synthesizer supply voltage is provided by the 5V regulator U4211.

In order to generate a high voltage to supply the phase detector (charge pump) output stage at pin VCP (U4201-47), a voltage of 13 VDC is being generated by the positive voltage multiplier circuitry (D4201, C4202, C4203). This voltage multiplier is basically a diode capacitor network driven by two (1.05MHz) 180 degrees out of phase signals (U4201-14 and -15).

Output LOCK (U4201-4) provides information about the lock status of the synthesizer loop. A high level at this output indicates a stable loop. IC U4201 provides the 16.8 MHz reference frequency at pin 19.

The serial interface (SRL) is connected to the microprocessor via the data line DATA (U4201-7), clock line CLK (U4201-8), and chip enable line CSX (U4201-9).

4.3 Voltage Controlled Oscillator (VCO)

The Voltage Controlled Oscillator (VCO) consists of the VCO/Buffer IC (VCOBIC, U4301), the TX and RX tank circuits, the external RX buffer stages, and the modulation circuitry.

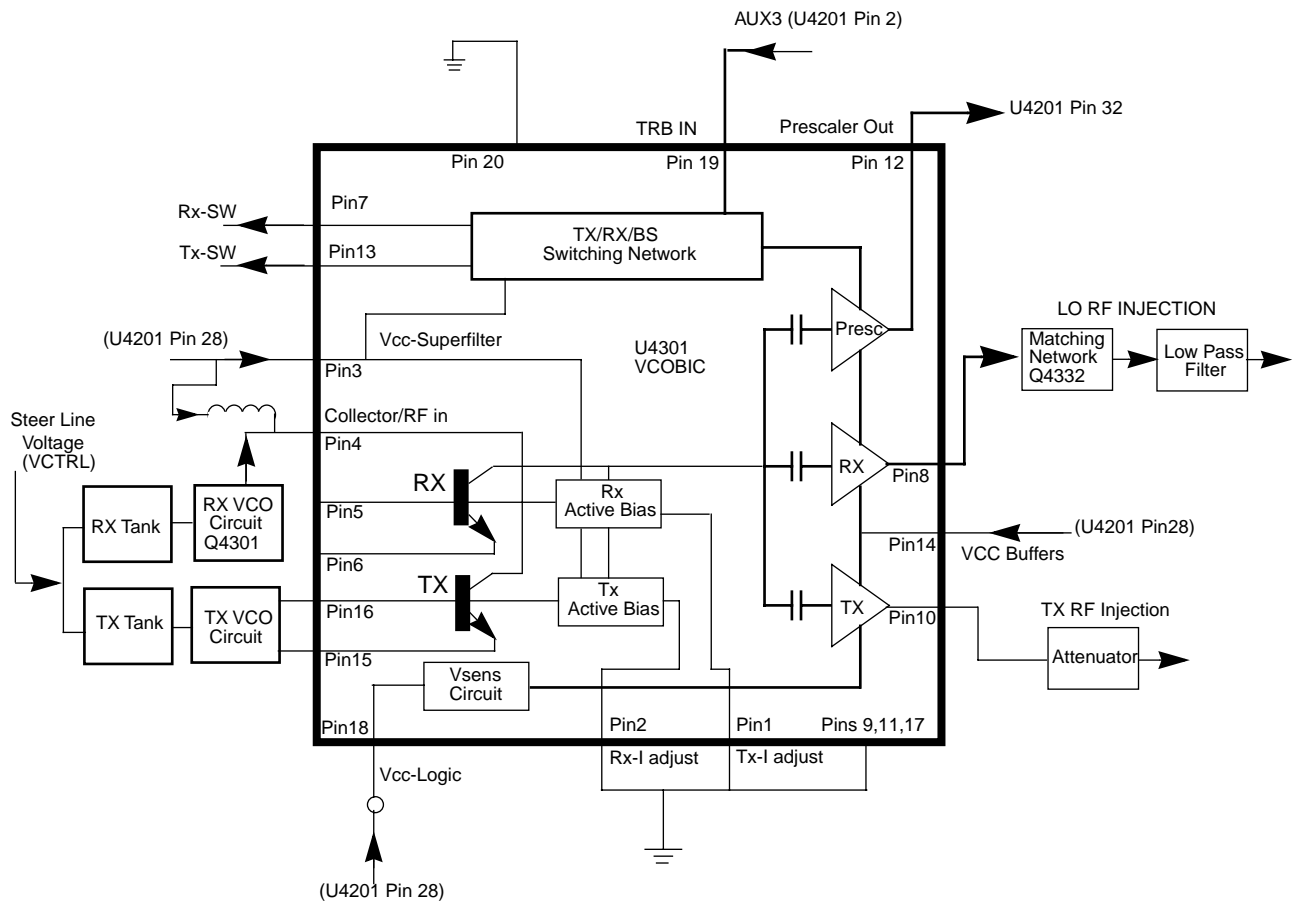

Figure 2-4 UHF VCO Block Diagram

The VCOBIC together with Fractional-N synthesizer (U4201) generates the required frequencies in both transmit and receive modes. The TRB line (U4301 pin 19) determines which tank circuits and internal buffers are to be enabled. A high level on TRB enables TX tank and TX output (pin 10), and a low enables RX tank and RX output (pin 8). A sample of the signal from the enabled output is routed from U4301 pin 12 (PRESC_OUT), via a low pass filter, to pin 32 of U4201 (PREIN).

A steering line voltage (VCTRL) between 3.0V and 10.0V at varactor diode CR4311 will tune the full TX frequency range (TXINJ) from 403 MHz to 470 MHz, and at varactor diodes CR4301, CR4302 and CR4303 will tune the full RX frequency range (RXINJ) from 358 MHz to 425 MHz. The tank circuits uses the Hartley configuration for wider bandwidth. For the RX tank circuit, an external transistor Q4301 is used in conjunction with the internal transistor for better side-band noise.

The external RX buffers (Q4332) are enabled by a high at U4201 pin 3 (AUX4) via transistor switch Q4333. In TX mode the modulation signal (VCOMOD) from the LVFRAC-N synthesizer IC (U4201 pin41) is applied modulation circuitry CR4321, R4321, R4322 and C4324, which modulates the TX VCO frequency via coupling capacitor C4321. Varactor CR4321 is biased for linearity from VSF.

4.4 Synthesizer Operation

The complete synthesizer subsystem comprises mainly of low voltage FRAC-N (LVFRACN) IC, Reference Oscillator (crystal oscillator with temperature compensation), charge pump circuitry, loop filter circuitry and DC supply. The output signal PRESC_OUT of the VCOBIC (U4301 pin12) is fed to pin 32 of U4201 (PREIN) via a low pass filter (C4229, L4225) which attenuates harmonics and provides the correct level to close the synthesizer loop.

The pre-scaler in the synthesizer (U4201) is basically a dual modulus pre-scaler with selectable divider ratios. This divider ratio of the pre-scaler is controlled by the loop divider, which in turn receives its inputs via the SRL. The output of the pre-scaler is applied to the loop divider. The output of the loop divider is connected to the phase detector, which compares the loop divider's output signal with the reference signal. The reference signal is generated by dividing down the signal of the reference oscillator (Y4261 or Y4262).

The output signal of the phase detector is a pulsed DC signal which is routed to the charge pump. The charge pump outputs a current at pin 43 of U4201 (IOUT). The loop filter (which consists of R4221-R4223, C4221-C4225, L4221) transforms this current into a voltage that is applied to the varactor diodes CR4311 for transmit, CR4301, CR4302 & CR4303 for receive and alters the output frequency of the VCO. The current can be set to a value fixed in the LVFRAC-N IC or to a value determined by the currents flowing into BIAS 1 (U4201-40) or BIAS 2 (U4201-39). The currents are set by the value of R4251 or R4252 respectively. The selection of the three different bias sources is done by software programming.

To reduce synthesizer lock time when new frequency data has been loaded into the synthesizer the magnitude of the loop current is increased by enabling the IADAPT (U4201-45) for a certain software programmable time (Adapt Mode). The adapt mode timer is started by a low to high transient of the CSX line. When the synthesizer is within the lock range the current is determined only by the resistors connected to BIAS 1, BIAS 2, or the internal current source. A settled synthesizer loop is indicated by a high level of signal LOCK (U4201-4).

The LOCK (U4201-4) signal is routed to one of the μP 's ADCs input U101-56. From the voltage the μP determines whether LOCK is active. In order to modulate the PLL the two spot modulation method is utilized. Via pin 10 (MODIN) on U4201 the audio signal is applied to both the A/D converter (low freq path) as well as the balance attenuator (high freq path). The A/D converter converts the low frequency analogue modulating signal into a digital code that is applied to the loop divider, thereby causing the carrier to deviate. The balance attenuator is used to adjust the VCO's deviation sensitivity to high frequency modulating signals. The output of the balance attenuator is present at the MODOUT port (U4201-41) and connected to the VCO modulation diode CR4321 via R4321, C4325.

5.0 UHF (403-470MHz) Transmitter Power Amplifier (PA) 40W

The radio's 40 W PA is a four stage amplifier used to amplify the output from the VCOBIC to the radio transmit level. It consists of the following four stages in the line-up. The first stage is a LDMOS predriver (U4401) that is controlled by pin 4 of PCIC (U4501) via Q4473 (CNTLVLTG). It is followed by another LDMOS stage (Q4421), an LDMOS stage (Q4431) and a bipolar final stage (Q4441).

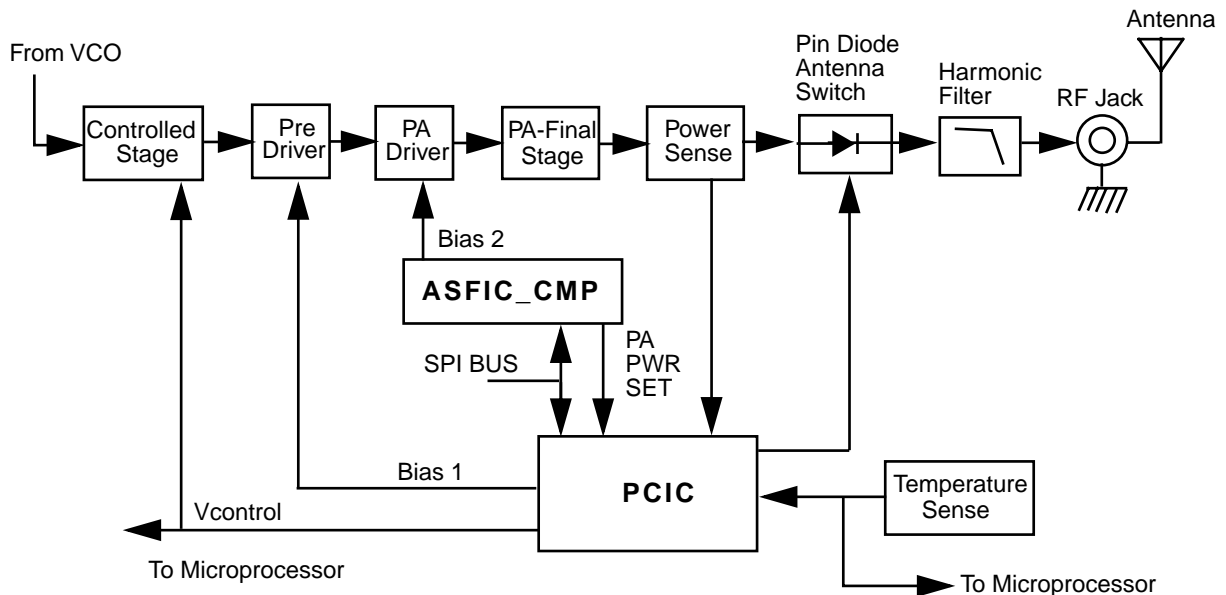

Figure 2-1 UHF Transmitter Block Diagram

Device Q4401 is surface mounted. Q4421, Q4431 and Q4441 are directly attached to the heat sink.

5.1 Power Controlled Stage

The first stage (U4401) amplifies the RF signal from the VCO (TXINJ) and controls the output power of the PA. The output power of the transistor U4401 is controlled by a voltage control line feed from the PCIC pin4(U4501). The control voltage simultaneously varies the bias of two FET stages within U4401. This biasing point determines the overall gain of U4401 and therefore its output drive level to Q4421, which in turn controls the output power of the PA.

In receive mode the voltage control line is at ground level and turns off Q4473 which in turn switches off the biasing voltage to U4401.

5.2 Pre-Driver Stage

The next stage is a 13dB gain LDMOS device (Q4421) which requires a positive gate bias and a quiescent current flow for proper operation. The voltage of the line PCIC_MOSBIAS_1 is set in transmit mode by PCIC pin 24 and fed to the gate of Q4421 via the resistive network R4480, R4416 and R4415. The bias voltage is tuned in the factory.

5.3 Driver Stage

The following stage is an enhancement-mode N-Channel MOSFET device (Q4431) providing a gain of 10dB. This device also requires a positive gate bias and a quiescent current flow for proper operation. The voltage of the line Bias_2_UHF_PA_1 is set in transmit mode by the ASFIC and fed to the gate of Q4431 via the resistive network R4632, R4631, R4485 and R4486. This bias voltage is also tuned in the factory. If the transistor is replaced, the bias voltage must be tuned using the Customer Programming Software (CPS). Care must be taken not to damage the device by exceeding the maximum allowed bias voltage. The device's drain current is drawn directly from the radio's DC supply voltage input, A+, via L4421.

5.4 Final Stage

The final stage uses the bipolar device Q4441. The device's collector current is also drawn from the radio's DC supply voltage input. To maintain class C operation, the base is DC-grounded by a series inductor (L4441) and a bead (L4440). A matching network consisting of C4441-C4444, C4491 and two striplines transforms the impedance to 50 Ohms and feeds the directional coupler.

5.5 Directional Coupler

The Bi-directional coupler is a microstrip printed circuit, which couples a small amount of the forward and reverse power of the RF power from Q4441. The coupled signal is rectified to an output power proportional DC voltage by the diodes D4451 & D4452 and sent to the RFIN of PCIC. The PCIC controls the gain of stage U4401 as necessary to hold this voltage constant, thus ensuring the forward power out of the radio to be held to a constant value.

5.6 Antenna Switch

The antenna switch consists of two PIN diodes, D4471 and D4472. In the receive mode, both diodes are off. Signals applied at the antenna jack J4401 are routed, via the harmonic filter, through network L4472, C4474 and C4475, to the receiver input. In the transmit mode, K9V1 turns on Q4471 which enables current sink Q4472, set to 96 mA by R4511 and VR4471. This completes a DC path from PASUPVLTG, through L4437, D4471, L4472, D4472, L4473, R4496 and the current sink, to ground. Both diodes are forward biased into conduction. The transmitter RF from the directional coupler is routed via D4471 to the harmonic filter and antenna jack. D4472 also conducts, shunting RF power and preventing it from reaching the receiver port (RXIN). L4472 is selected to appear as a broadband $\lambda/4$ wave transmission line, making the short circuit presented by D4472 appear as an open circuit at the junction of D4472 and the receiver path.

5.7 Harmonic Filter

Inductors L4491, L4492, L4493 and capacitors C4448, C4492, C4494, C4496 and C4498 form a low-pass filter to attenuate harmonic energy of the transmitter to specifications level. R4491 is used to drain electrostatic charge that might otherwise build up on the antenna. The harmonic filter also prevents high level RF signals above the receiver passband from reaching the receiver circuits, improving spurious response rejection.

5.8 Power Control

The transmitter uses the Power Control IC (PCIC, U4501) to control the power output of the radio. A portion of the forward RF power from the transmitter is sampled by the bi-directional coupler and rectified, to provide a DC voltage to the RFIN port of the PCIC (pin 1) which is proportional to the sampled RF power.

The PCIC has internal digital to analog converters (DACs) which provide the reference voltage of the control loop. The reference voltage level is programmable through the SPI line of the PCIC. This reference voltage is proportional to the desired power setting of the transmitter, and is factory programmed at several points across the frequency range of the transmitter to offset frequency response variations of the transmitter's power detector circuitry.

The PCIC provides a DC output voltage at pin 4 (INT) which is applied as CNTLVLTG to the power-adjust input pin of the first transmitter stage U4401. This adjusts the transmitter power output to the intended value. Variations in forward transmitter power cause the DC voltage at pin 1 to change, and the PCIC adjusts the control voltage above or below its nominal value to raise or lower output power.

Capacitors C4502-4, in conjunction with resistors and integrators within the PCIC, control the transmitter power-rise (key-up) and power-decay (de-key) characteristic to minimize splatter into adjacent channels.

U4502 is a temperature-sensing device, which monitors the circuit board temperature in the vicinity of the transmitter driver and final devices, and provides a dc voltage to the PCIC (TEMP, pin 29) proportional to temperature. If the DC voltage produced exceeds the set threshold in the PCIC, the transmitter output power will be reduced so as to reduce the transmitter temperature.

TROUBLESHOOTING CHARTS

1.0 Troubleshooting Flow Chart for Receiver (Sheet 1 of 2)

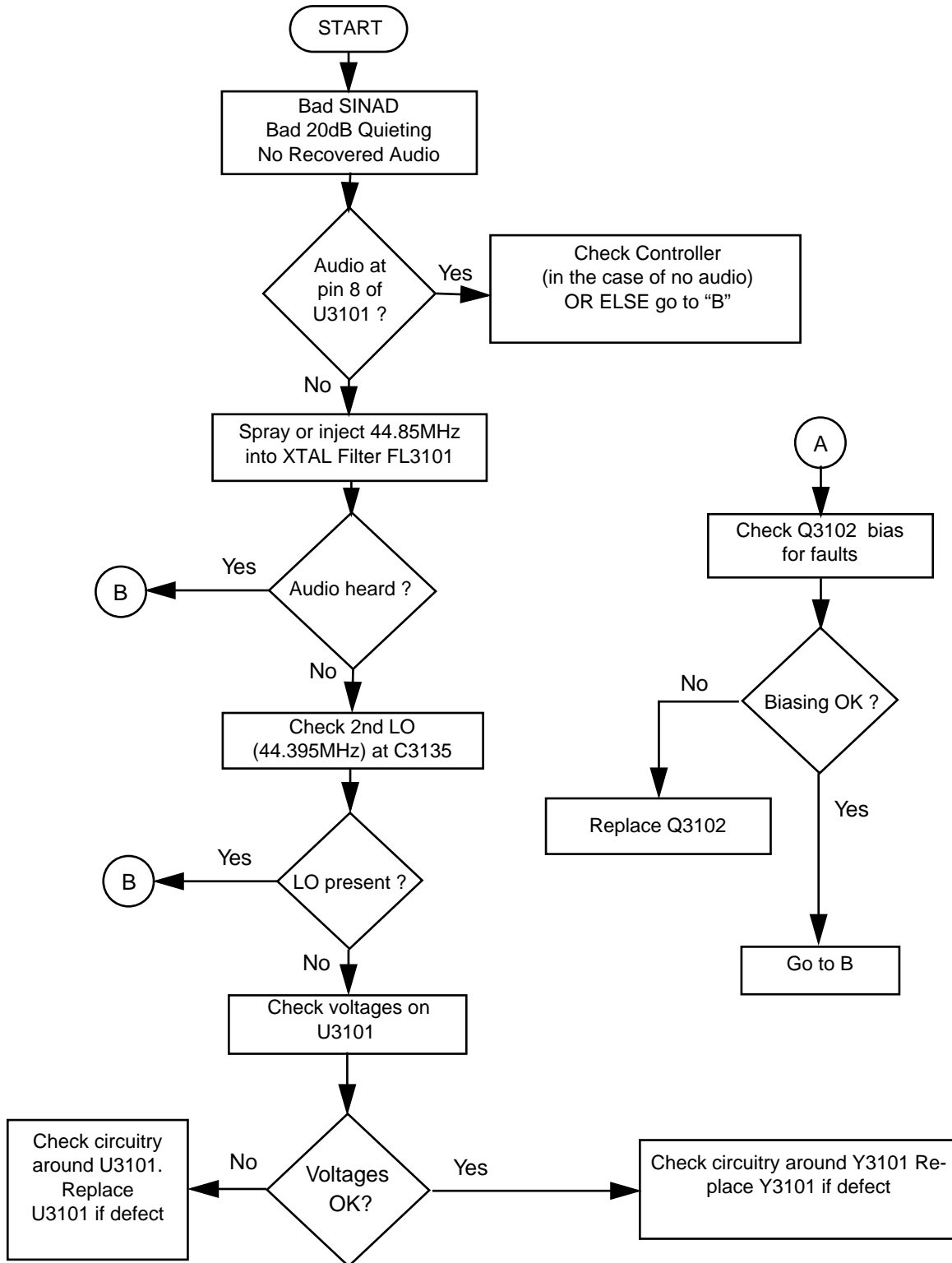

1.1 Troubleshooting Flow Chart for Receiver (Sheet 2 of 2)

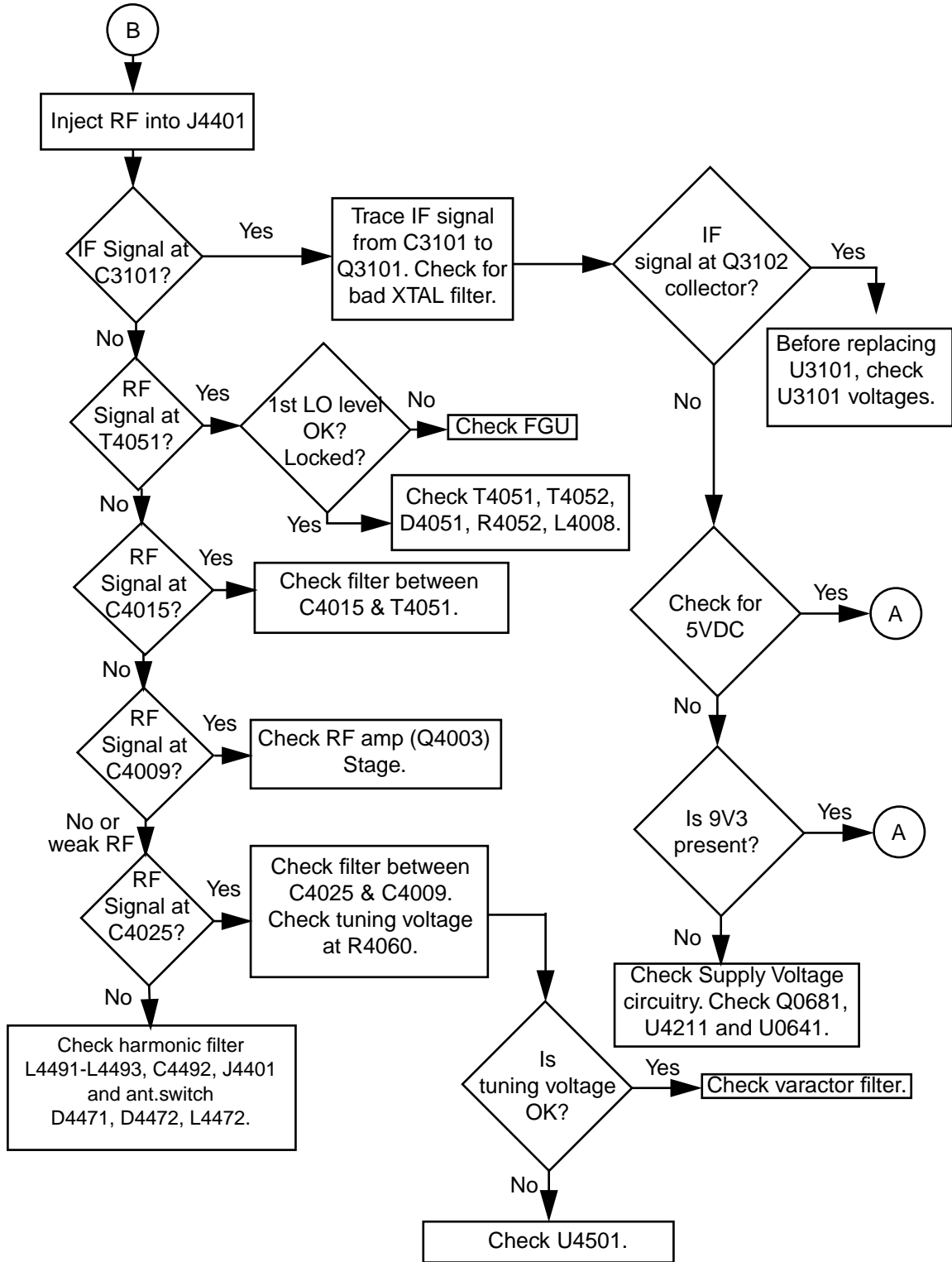

2.0 Troubleshooting Flow Chart for 25W Transmitter (Sheet 1 of 3)

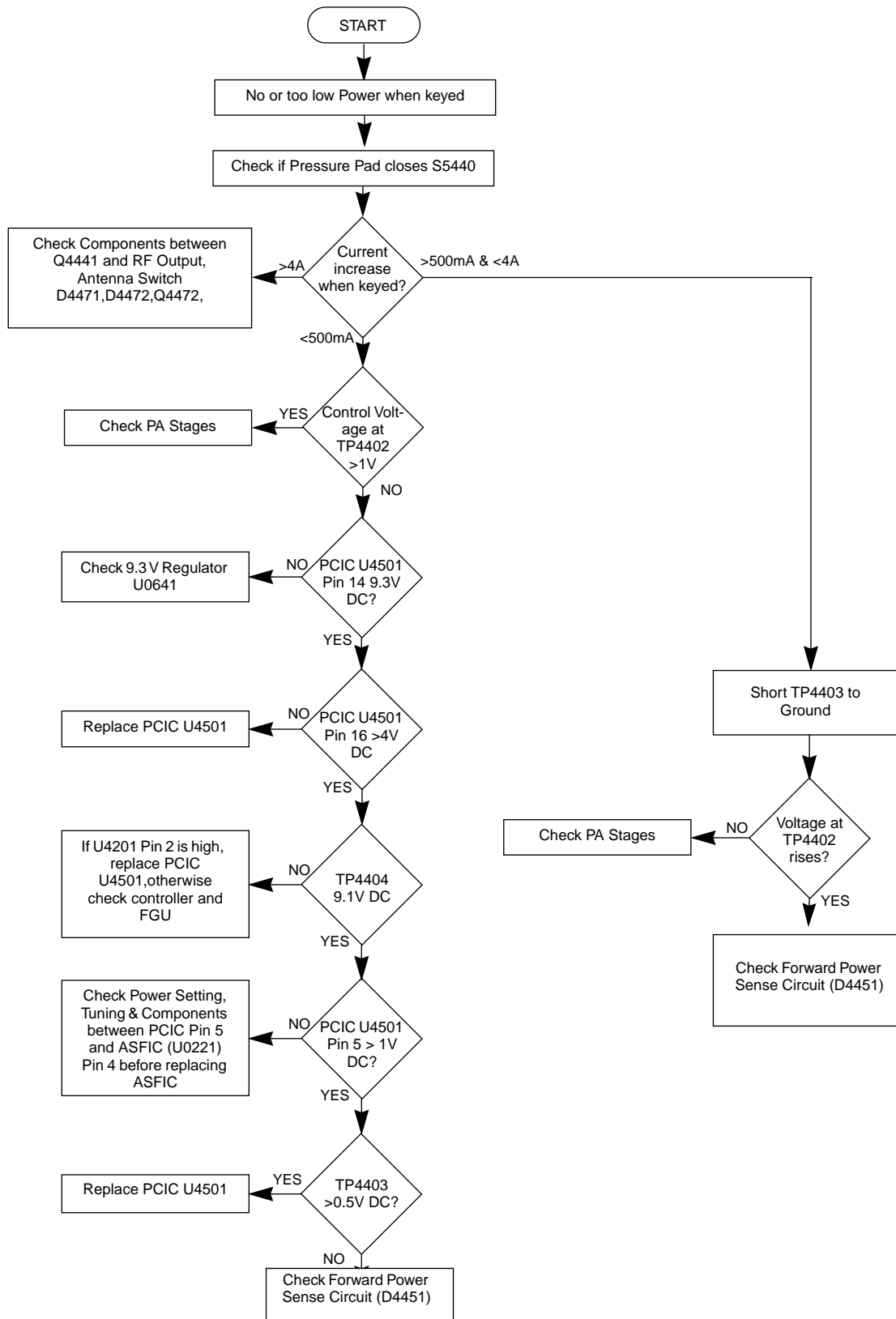

2.1 Troubleshooting Flow Chart for 25W Transmitter (Sheet 2 of 3)

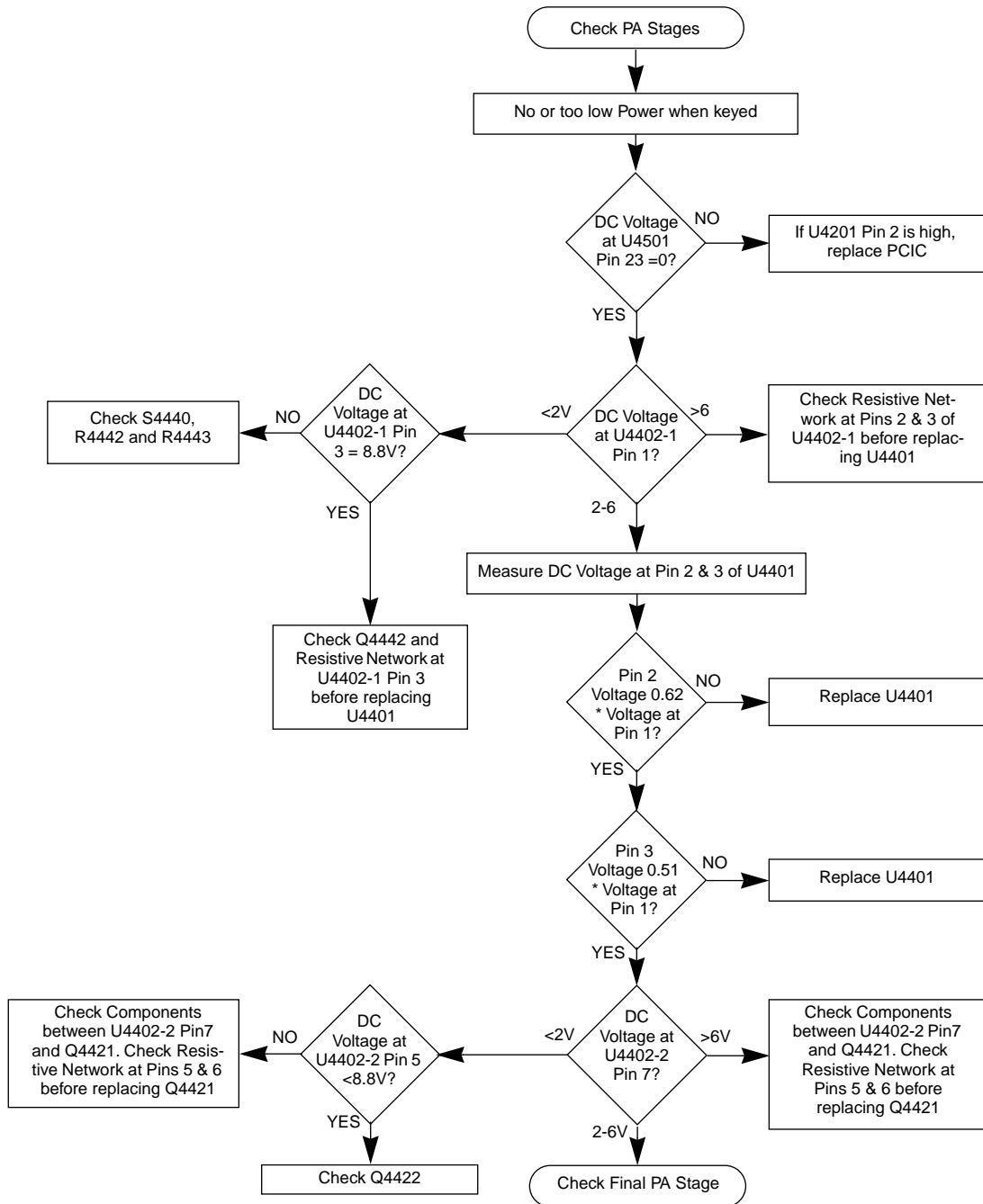

2.2 Troubleshooting Flow Chart for 25W Transmitter (Sheet 3 of 3)

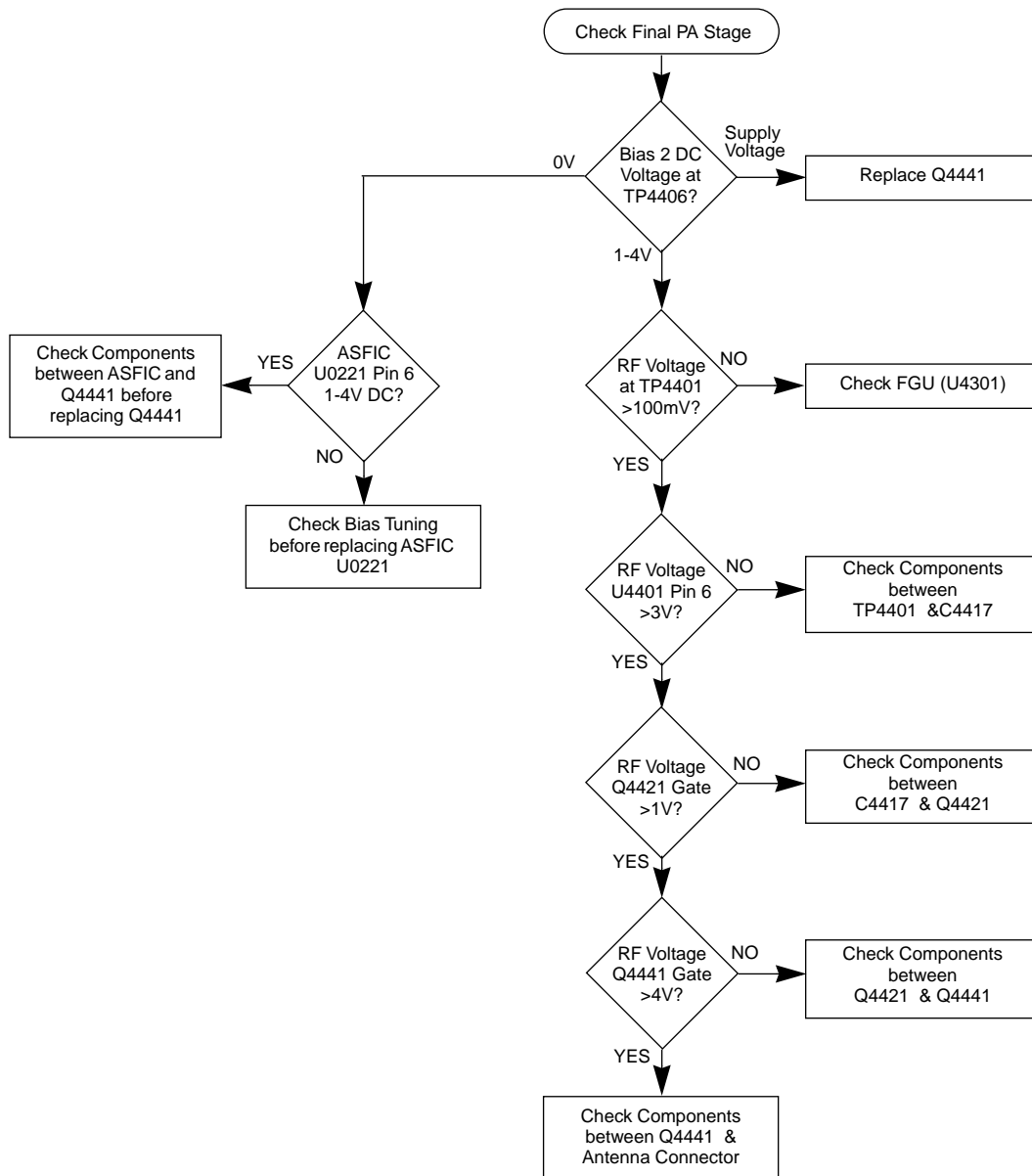

3.0 Troubleshooting Flow Chart for UHF 40W Transmitter

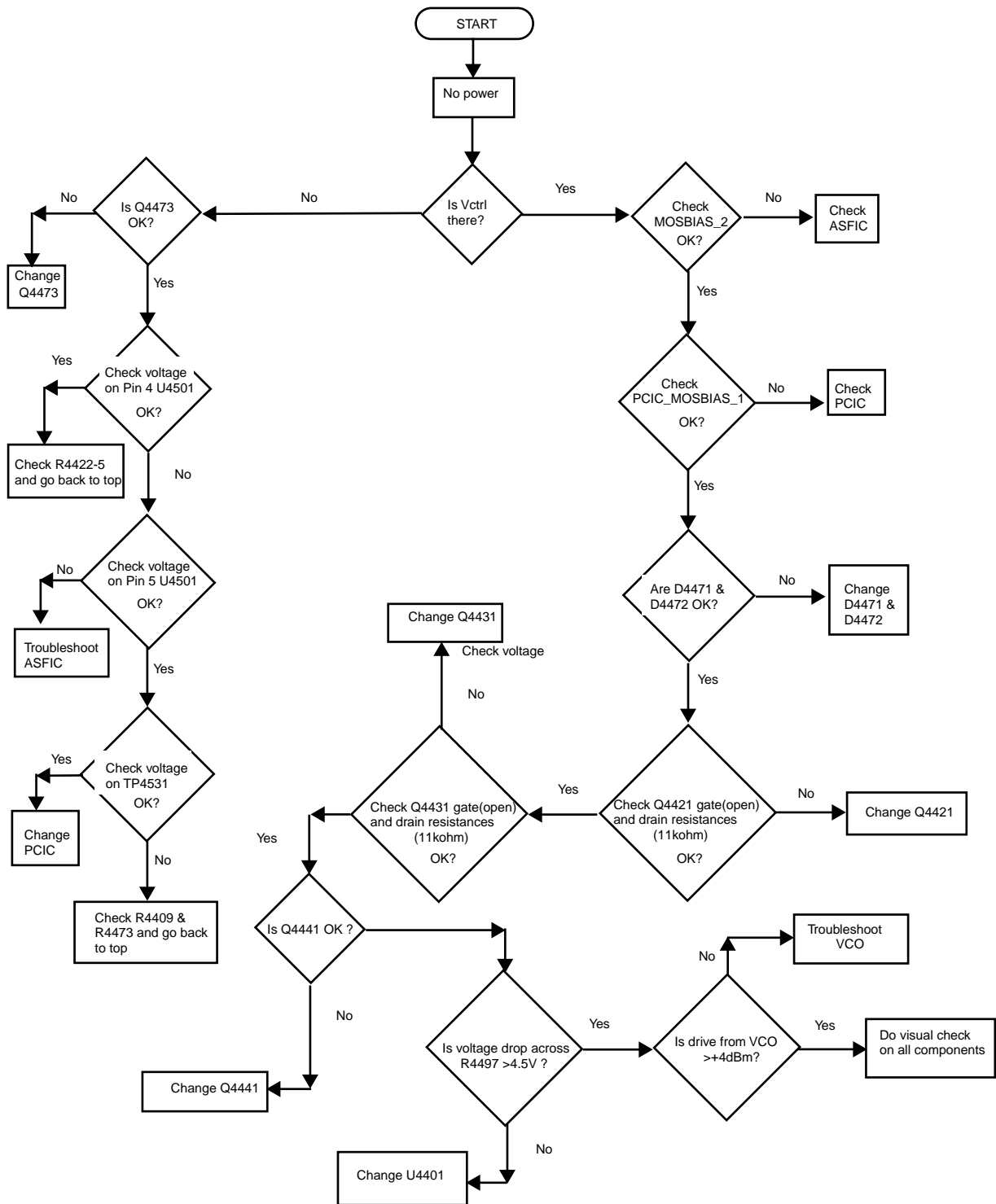

4.0 Troubleshooting Flow Chart for Synthesizer

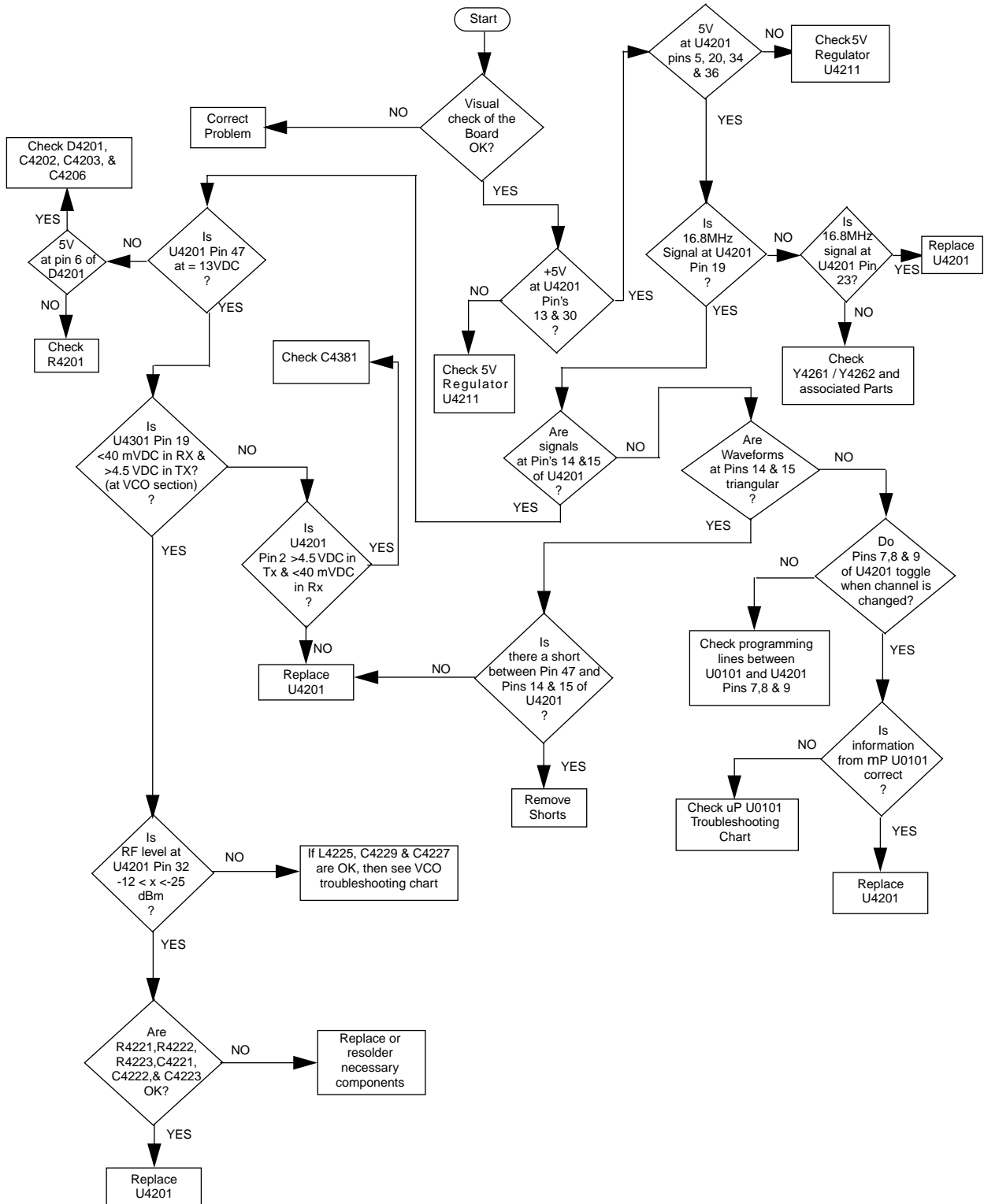

5.0 Troubleshooting Flow Chart for VCO

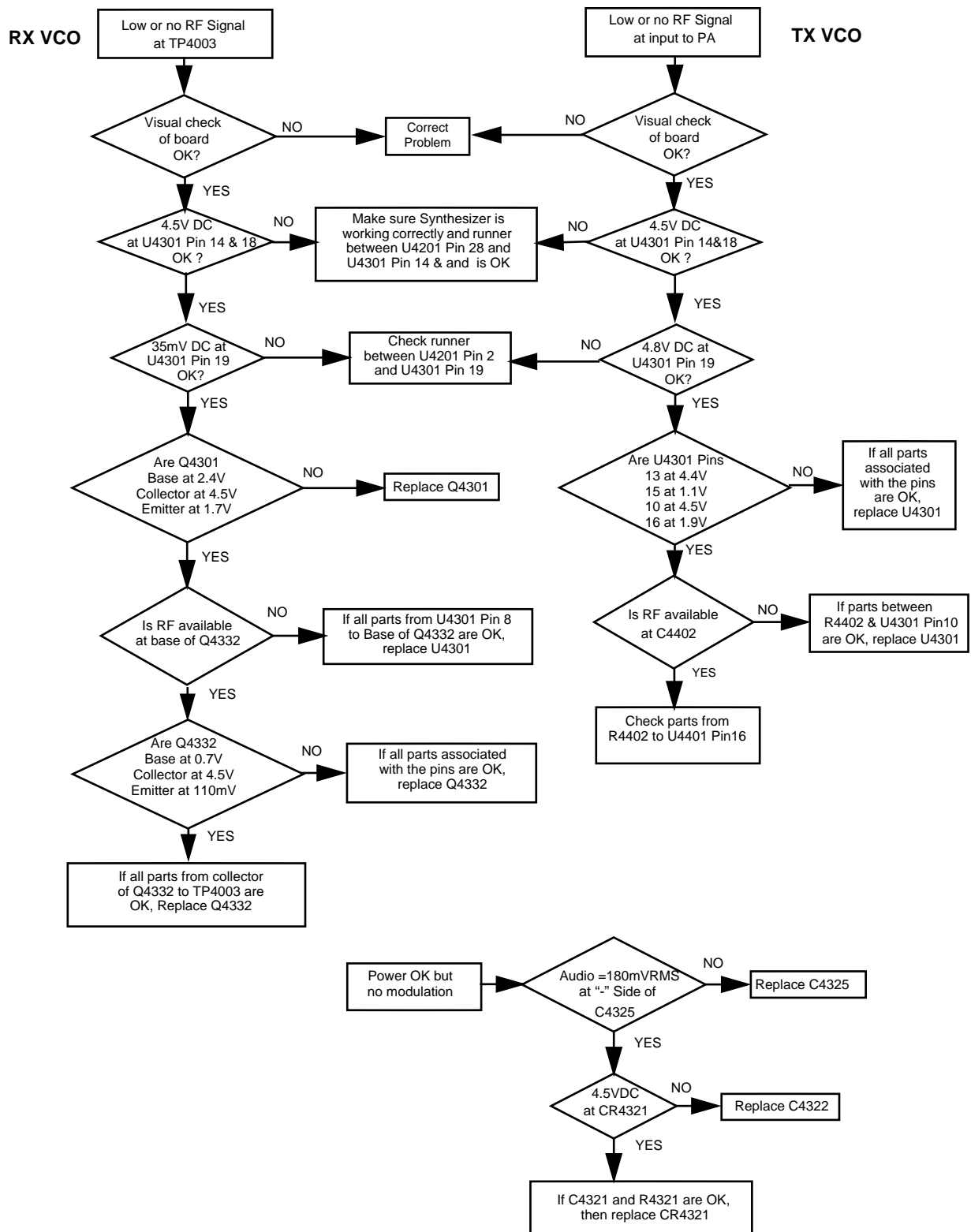

Chapter 4

UHF PCB/SCHEMATICS/PARTS LISTS

1.0 Allocation of Schematics and Circuit Boards

1.1 Controller Circuits

The UHF circuits are contained on the printed circuit board (PCB) which also contains the Controller circuits. This Chapter shows the schematics for the UHF circuits only, refer to the Controller section for details of the related Controller circuits . The PCB component layouts and the Parts Lists in this Chapter show both the Controller and UHF circuit components. The UHF schematics and the related PCB and parts list are shown in the tables below.

Table 4-1 UHF 1-25W Diagrams and Parts Lists

PCB : 8485670z02 Main Board Top Side 8485670z02 Main Board Bottom Side	Page 4-3 Page 4-4
SCHEMATICS Power Amplifier 1 - 25W FRACN Voltage Controlled Oscillator Receiver Front End IF	Page 4-5 Page 4-6 Page 4-7 Page 4-8 Page 4-9
Parts List 8485670z02	Page 4-10
Controller version is T7	

Table 4-2 UHF 25-40W Diagrams and Parts Lists

PCB : 8480643z06 Main Board Top Side 8480643z06 Main Board Bottom Side	Page 4-13 Page 4-14
SCHEMATICS Power Amplifier 25 - 40W FRACN Voltage Controlled Oscillator Receiver Front End IF	Page 4-15 Page 4-16 Page 4-17 Page 4-18 Page 4-19
Parts List 8480643z06	Page 4-20
Controller version is T6	

Table 4-3 UHF 1-25W Diagrams and Parts Lists

PCB : 8485670z03 Main Board Top Side 8485670z03 Main Board Bottom Side	Page 4-23 Page 4-24
SCHEMATICS Power Amplifier 1 - 25W FRACN Voltage Controlled Oscillator Receiver Front End IF	Page 4-25 Page 4-26 Page 4-27 Page 4-28 Page 4-29
Parts List 8485670z03	Page 4-30
Controller version is T9	

2.0 UHF 1-25W Band1 PCB 8485670z02 / Schematics

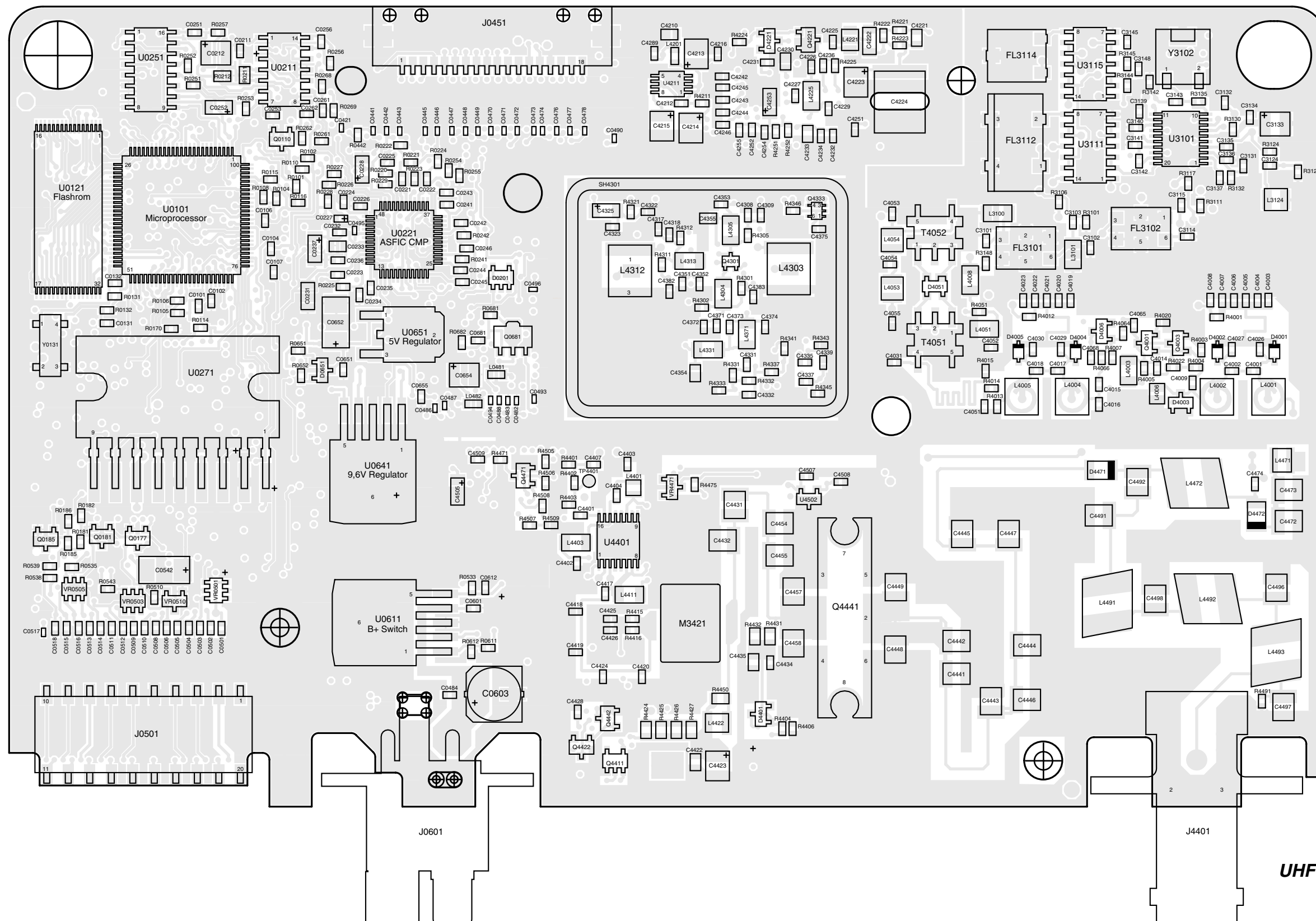

ZWG0130518-A
UHF (403-470MHz) 1-25W
8485670z02 Top Side

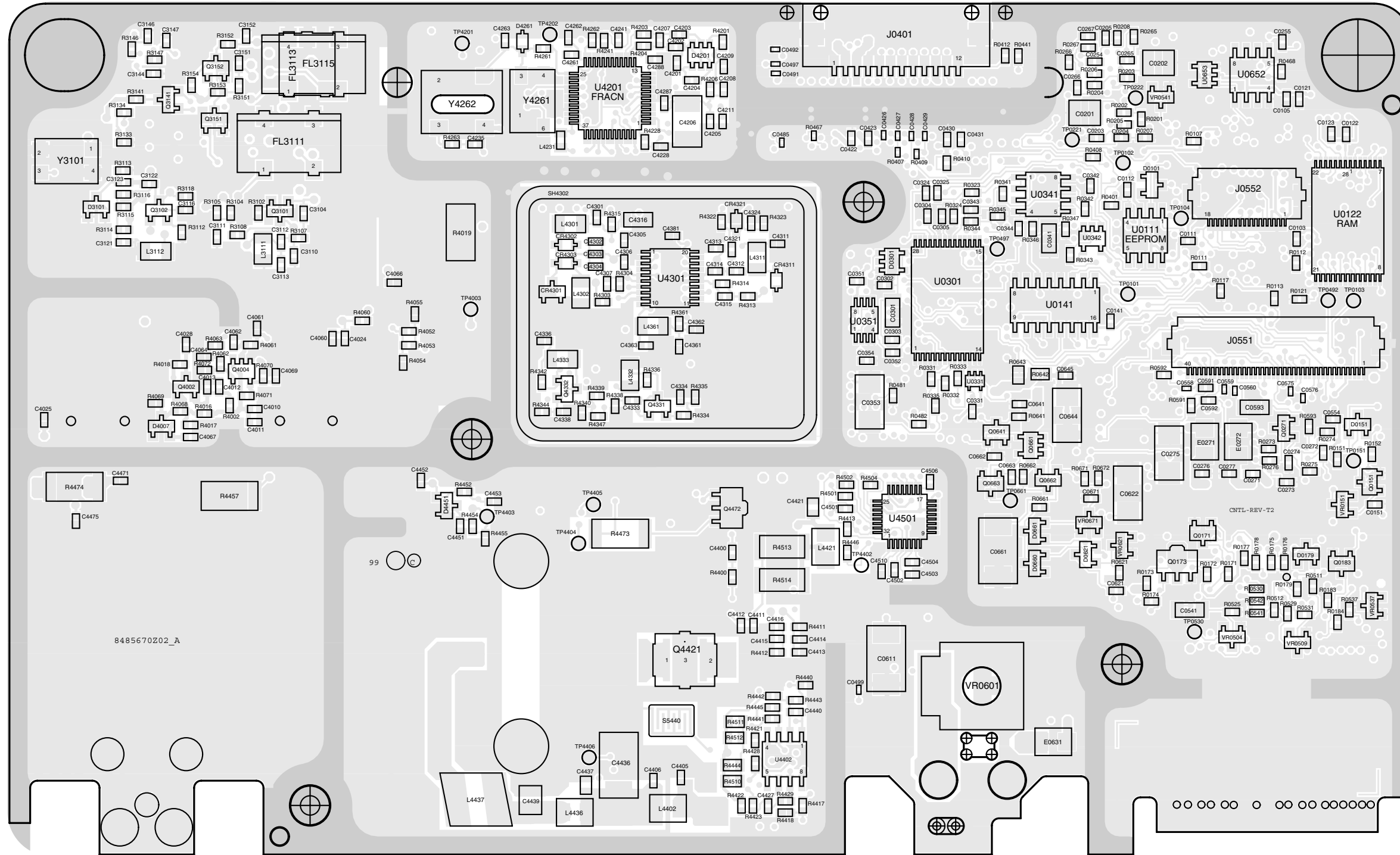

ZWG0130519-A

UHF (403-470MHz) 1-25W 8485670z02 Top Side

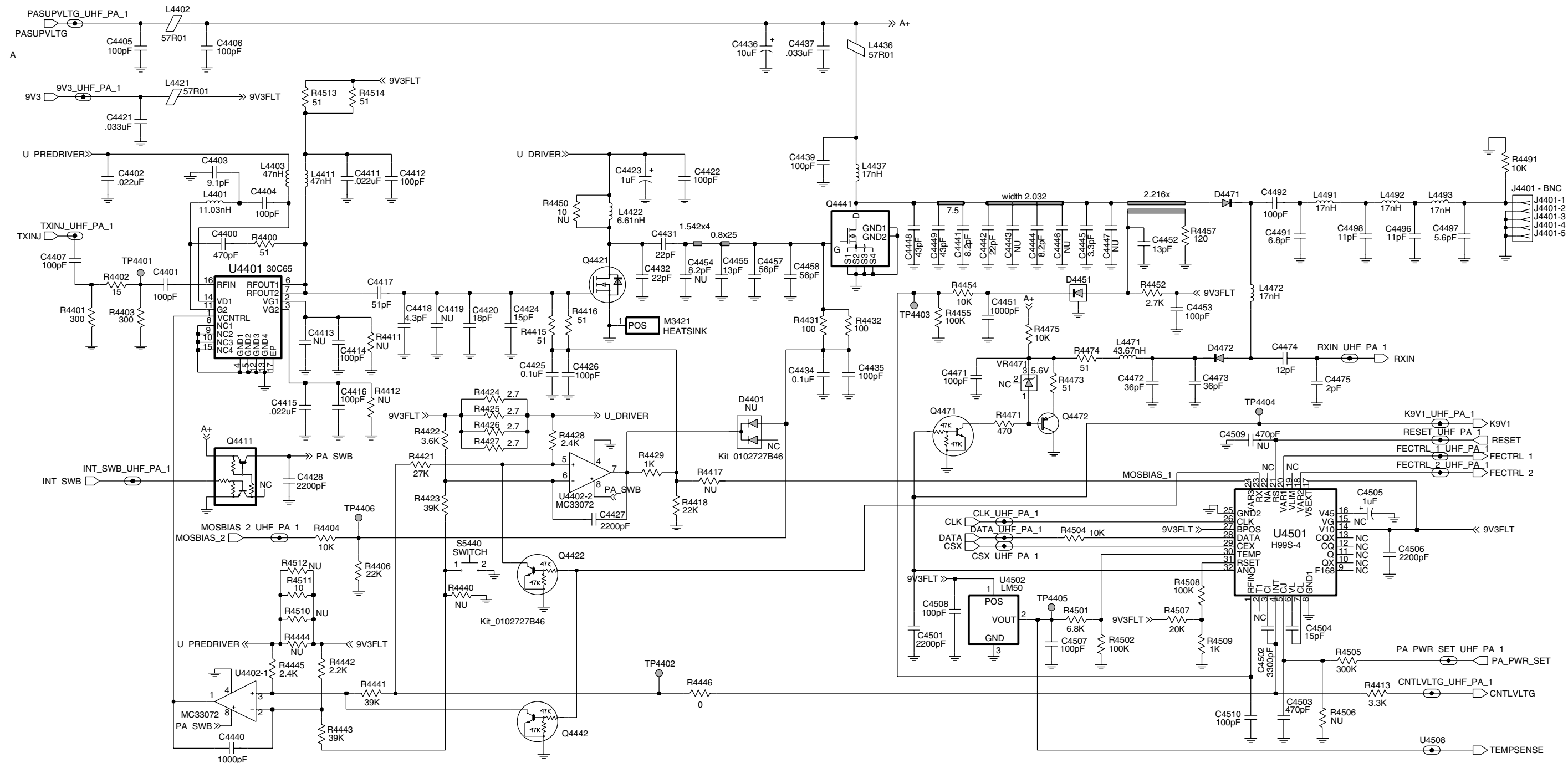

ZWG0130520-B

UHF (403-470MHz) Power Amplifier 1 - 25W

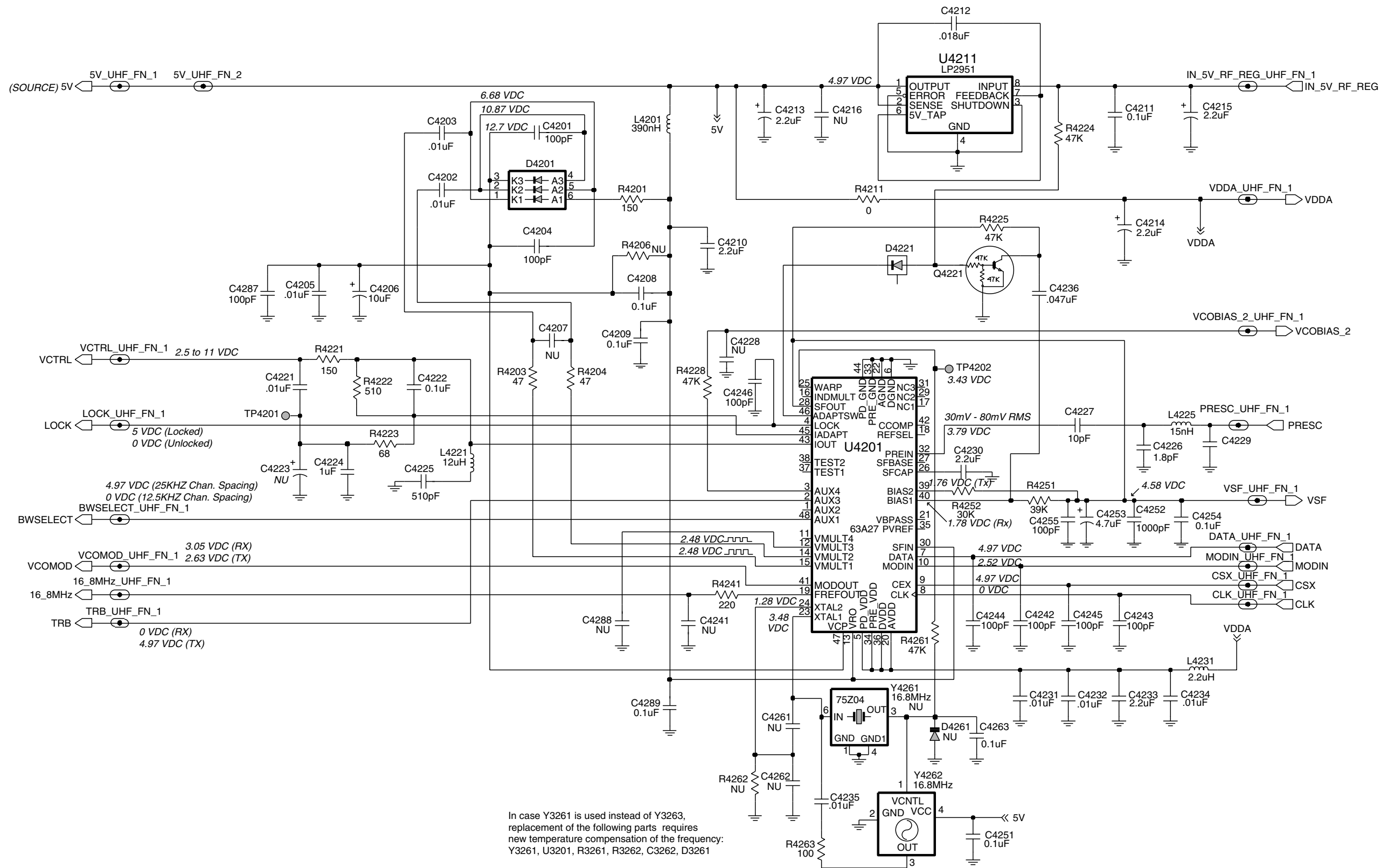

ZWG0130521-B

UHF (403-470 MHz) FRACN

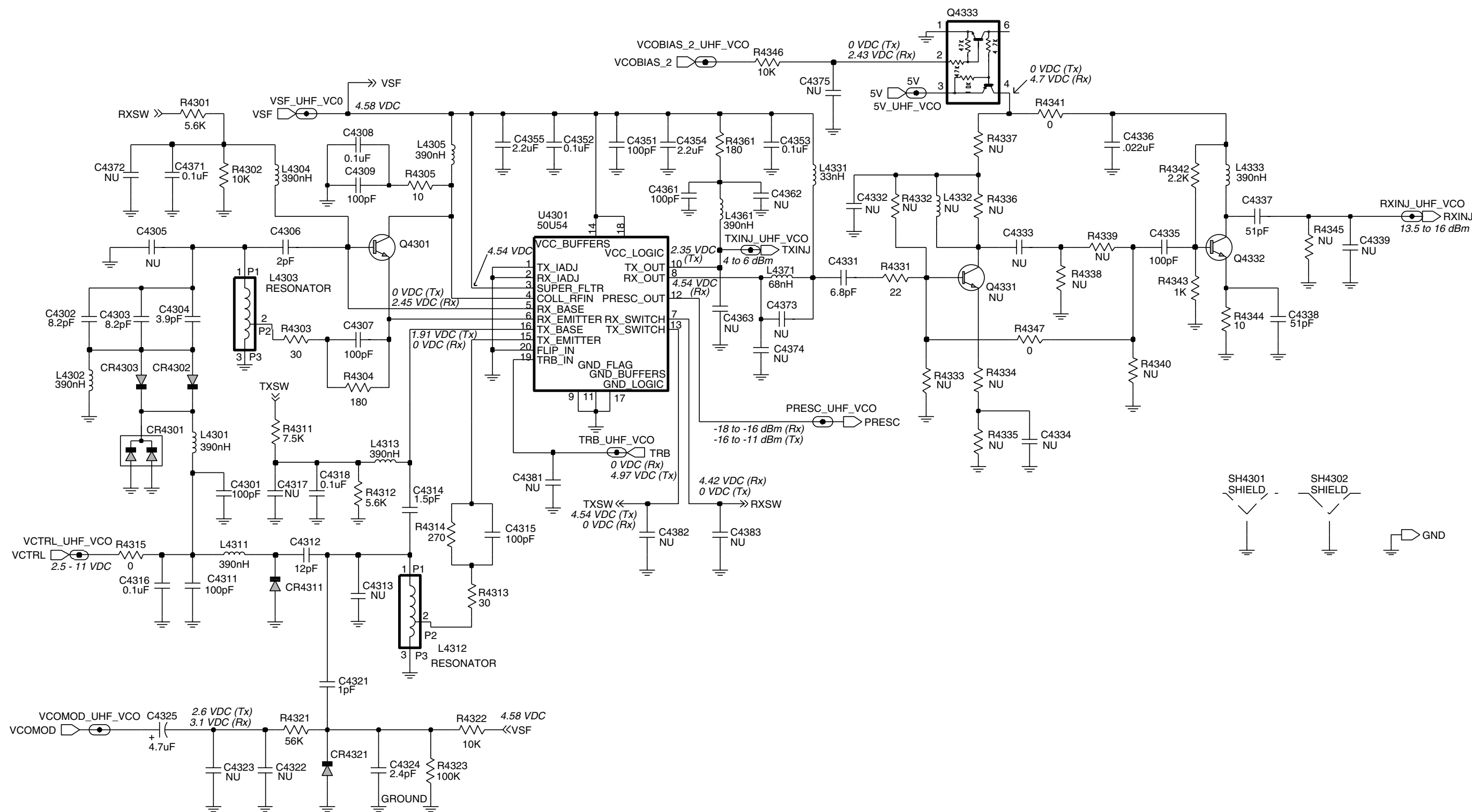

ZWG0130523-A

UHF (403-470 MHz) Voltage Controlled Oscillator

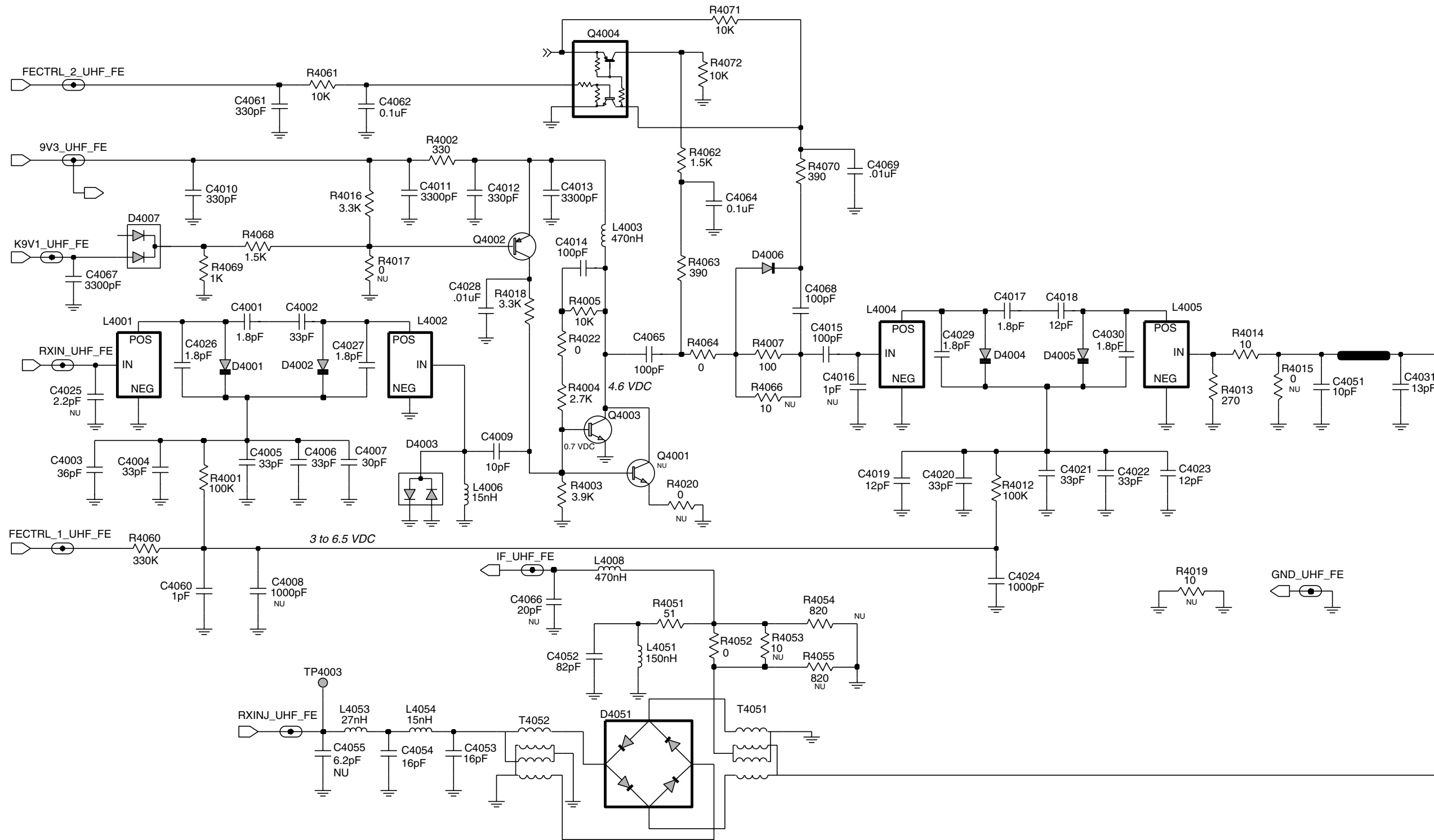

UHF (403-470 MHz) Receiver Front End

ZWG0130524-B

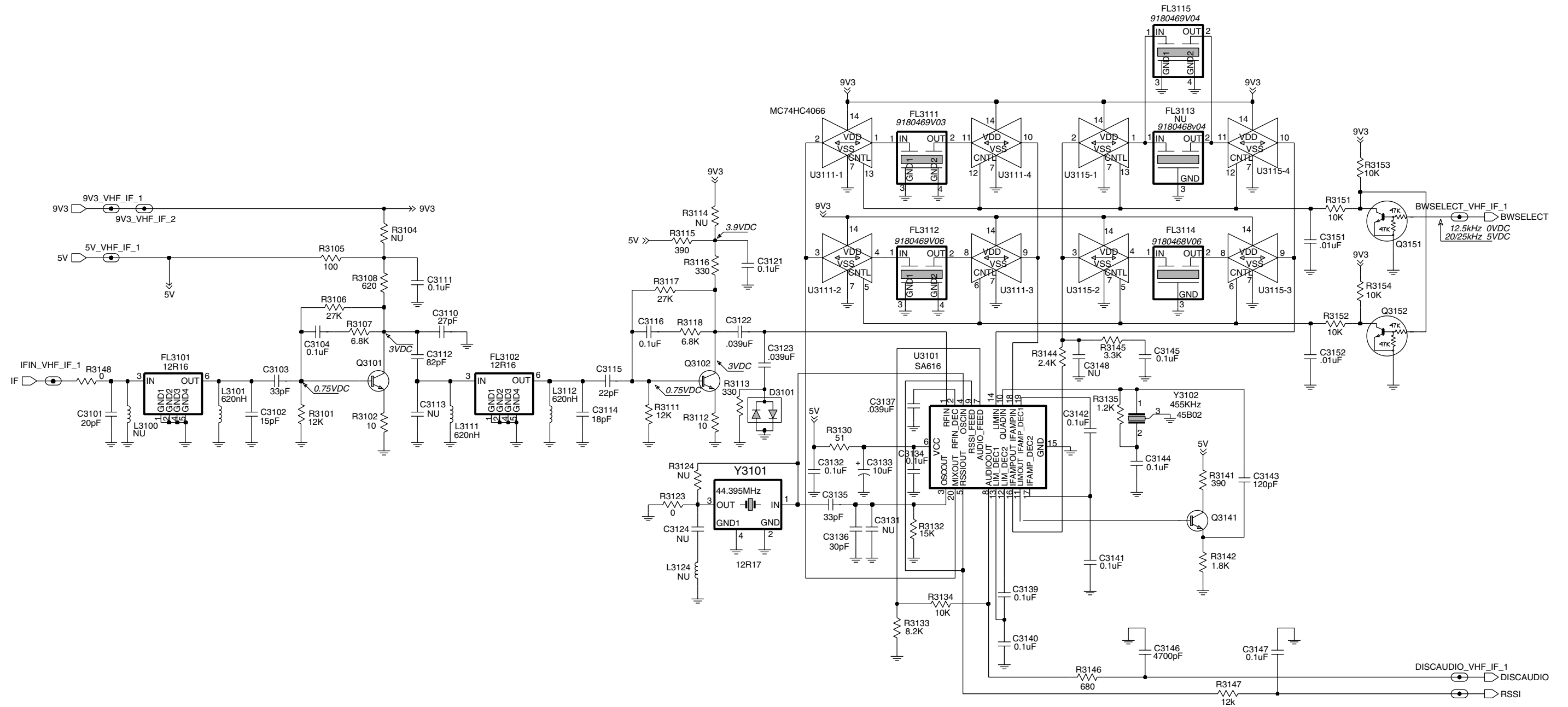

ZWG0130522-A

UHF (403-470 MHz) IF

2.1 UHF PCB 8485670z02 Parts List 1-25W

Circuit Ref	Motorola Part No.	Description
C3101	2113740F34	20pF
C3102	2113740F31	15pF
C3103	2113740F39	33pF
C3104	2113743E20	0.1uF
C3110	2113740F37	27pF
C3111	2113743E20	0.1uF
C3112	2113740F49	82pF
C3114	2113740F33	18pF
C3115	2113740F35	22pF
C3116	2113743E20	0.1uF
C3121	2113743E20	0.1uF
C3122	2113743E11	0.039uF
C3123	2113743E11	0.039uF
C3132	2113743E20	0.1uF
C3133	2311049A57	10uF
C3134	2113743E20	0.1uF
C3135	2113740L30	33pF
C3136	2113740L29	30pF
C3137	2113743E11	0.039uF
C3139	2113743E20	0.1uF
C3140	2113743E20	0.1uF
C3141	2113743E20	0.1uF
C3142	2113743E20	0.1uF
C3143	2113740F53	120pF
C3144	2113743E20	0.1uF
C3145	2113743E20	0.1uF
C3146	2113741F41	4700pF
C3147	2113743E20	0.1uF
C3151	2113741F49	0.01uF
C3152	2113741F49	0.01uF
C4001	2113740F09	1.8pF
C4002	2113740F39	33pF
C4003	2113740F40	36pF
C4004	2113740F39	33pF
C4005	2113740F39	33pF
C4006	2113740F39	33pF
C4007	2113740F38	30pF
C4008	2113741F25	1000pF
C4009	2113740F27	10pF
C4010	2113741F13	330pF
C4011	2113741F37	3300pF
C4012	2113741F13	330pF
C4013	2113741F37	3300pF
C4014	2113740F51	100pF
C4015	2113740F51	100pF
C4017	2113740F09	1.8pF
C4018	2113740F29	12pF
C4019	2113740F29	12pF
C4020	2113740F39	33pF
C4021	2113740F39	33pF

Circuit Ref	Motorola Part No.	Description
C4022	2113740F39	33pF
C4023	2113740F29	12pF
C4024	2113741F25	1000pF
C4026	2113740F09	1.8pF
C4027	2113740F09	1.8pF
C4028	2113741F49	0.01uF
C4029	2113740F09	1.8pF
C4030	2113740F09	1.8pF
C4031	2113740F30	13pF
C4051	2113740F27	10pF
C4052	2113740F49	82pF
C4053	2113740F32	16pF
C4054	2113740F32	16pF
C4061	2113740F63	330pF
C4062	2113743E20	0.1uF
C4064	2113743E20	0.1uF
C4065	2113740F51	100pF
C4067	2113741F37	3300pF
C4068	2113740F51	100pF
C4069	2113741F49	0.01uF
C4201	2113740F51	100pF
C4202	2113741F49	0.01uF
C4203	2113741F49	0.01uF
C4204	2113740F51	100pF
C4205	2113741F49	0.01uF
C4206	2311049J25	10uF
C4208	2113743E20	0.1uF
C4209	2113743E20	0.1uF
C4210	2104993J02	2.2uF
C4211	2113743E20	0.1uF
C4212	2113743E05	0.018uF
C4213	2311049A09	2.2uF
C4214	2311049A09	2.2uF
C4215	2311049A09	2.2uF
C4221	2109720D01	0.01uF
C4222	2109720D14	0.1uF
C4224	0882422W23	1uF
C4225	2113741F18	510pF
C4227	2113740L16	8.2pF
C4230	2104993J02	2.2uF
C4231	2113741F49	0.01uF
C4232	2113741F49	0.01uF
C4233	2104993J02	2.2uF
C4234	2113741F49	0.01uF
C4235	2113741F49	0.01uF
C4236	2113743E12	0.047uF
C4242	2113740F51	100pF
C4243	2113740F51	100pF
C4244	2113740F51	100pF
C4245	2113740F51	100pF
C4246	2113740F51	100pF

Circuit Ref	Motorola Part No.	Description
C4251	2113743E20	0.1uF
C4252	2113741F25	1000pF
C4253	2311049A56	4.7uF
C4254	2113743E20	0.1uF
C4255	2113740F51	100pF
C4263	2113743E20	0.1uF
C4287	2113740F51	100pF
C4289	2113743E20	0.1uF
C4301	2113740F51	100pF
C4302	2113740L16	8.2pF
C4303	2113740L16	8.2pF
C4304	2113740L08	3.9pF
C4306	2113740L01	2pF
C4307	2113740F51	100pF
C4308	2113743E20	0.1uF
C4309	2113740F51	100pF
C4311	2113740F51	100pF
C4312	2113740F29	12pF
C4314	2113740F07	1.5pF
C4315	2113740F51	100pF
C4316	2109720D14	0.1uF
C4318	2113743E20	0.1uF
C4321	2113740F03	1pF
C4324	2113740L03	2.4pF
C4325	2311049A56	4.7uF
C4331	2113740L14	6.8pF
C4335	2113740F51	100pF
C4336	2113743E07	0.022uF
C4337	2113740F44	51pF
C4338	2113740F44	51pF
C4351	2113740F51	100pF
C4352	2113743E20	0.1uF
C4353	2113743E20	0.1uF
C4354	2104993J02	2.2uF
C4355	2104993J02	2.2uF
C4361	2113740F51	100pF
C4371	2113743E20	0.1uF
C4400	2113740F67	470pF
C4401	2113740F51	100pF
C4402	2113743E07	0.022uF
C4403	2113740F26	9.1pF
C4404	2113740F51	100pF
C4405	2113740F51	100pF
C4406	2113740F51	100pF
C4407	2113740F51	100pF
C4411	2113743E07	0.022uF
C4412	2113740F51	100pF
C4414	2113740F51	100pF
C4415	2113743E07	0.022uF
C4416	2113740F51	100pF
C4417	2113740F44	51pF

Circuit Ref	Motorola Part No.	Description
C4418	2113740F18	4.3pF
C4420	2113740F33	18pF
C4421	2113741A57	0.033uF
C4422	2113740A55	100pF
C4423	2311049A08	1uF
C4424	2113740F31	15pF
C4425	2113743E20	0.1uF
C4426	2113740F51	100pF
C4427	2113741F33	2200pF
C4428	2113741F33	2200pF
C4431	2111078B22	22pF
C4432	2111078B22	22pF
C4434	2113743E20	0.1uF
C4435	2113740A55	100pF
C4436	2311049A45	10uF
C4437	2113741A57	0.033uF
C4439	2111078B42	100pF
C4440	2113741F25	1000pF
C4441	2111078B11	8.2pF
C4442	2111078B22	22pF
C4444	2111078B11	8.2pF
C4445	2111078B01	3.3pF
C4448	2111078B33	43pF
C4449	2111078B33	43pF
C4451	2113741F25	1000pF
C4452	2113740F30	13pF
C4453	2113740F51	100pF
C4455	2111078B16	13pF
C4457	2111078B36	56pF
C4458	2111078B36	56pF
C4471	2113740F51	100pF
C4472	2111078B31	36pF
C4473	2111078B31	36pF
C4474	2113740F29	12pF
C4475	2113740F10	2pF
C4491	2111078B09	6.8pF
C4492	2111078B42	100pF
C4496	2111078B14	11pF
C4497	2111078B07	5.6pF
C4498	2111078B14	11pF
C4501	2113741F33	2200pF
C4502	2113741F37	3300pF
C4503	2113741F17	470pF
C4504	2113743E03	15nF
C4505	2311049A07	1uF
C4506	2113741F33	2200pF
C4507	2113740F51	100pF
C4508	2113740F51	100pF
C4510	2113740F51	100pF
CR4301	4805649Q13	DIODE, VARACTOR
CR4302	4862824C01	DIODE VARACTOR

Circuit Ref	Motorola Part No.	Description
CR4303	4862824C01	DIODE VARACTOR
CR4311	4802245J22	DIODE, VARACTOR
CR4321	4862824C01	DIODE VARACTOR
D3101	4880154K03	DIODE DUAL SCHOTTKY
D4001	4862824C01	DIODE VARACTOR
D4002	4862824C01	DIODE VARACTOR
D4003	4880154K03	DIODE DUAL SCHOTTKY
D4004	4862824C01	DIODE VARACTOR
D4005	4862824C01	DIODE VARACTOR
D4006	4880142L01	Diode
D4007	4813833C02	DIODE, DUAL 70V
D4051	4886143B01	DIODE, MIXER
D4201	4802233J09	DIODE, TRIPLE
D4221	4813825A05	DIODE
D4451	4813825A05	DIODE
D4471	4802482J02	DIODE
D4472	4802482J02	DIODE
FL3101	9180112R16	2 POLE 44.85 MHZ XSTAL
FL3102	9180112R16	2 POLE 44.85 MHZ XSTAL
FL3111	9180469V03	CERAMIC FILTER, 455KHz
FL3112	9180469V06	CERAMIC FILTER, 455KHz
FL3114	9180468V06	CERAMIC FILTER, 455KHz
FL3115	9180469V04	CERAMIC FILTER, 455KHz
J4401	0986166B01	CONN_J
L3101	2462587T25	620nH
L3111	2462587T25	620nH
L3112	2462587T25	620nH
L4003	2462587T23	470nH
L4006	2462587V24	15nH
L4008	2462587T23	470nH
L4051	2462587T17	150nH
L4053	2462587N46	27nH
L4054	2462587N43	15nH
L4201	2462587Q42	390nH
L4221	2462587P25	12uH
L4225	2462587T40	33nH
L4231	2462587Q20	2.2uH
L4301	2462587T22	390nH
L4302	2462587T22	390nH
L4303	2460593C01	RESONATOR
L4304	2462587T22	390nH
L4305	2462587T22	390nH
L4311	2462587T22	390nH
L4312	2460593C01	RESONATOR
L4313	2462587T22	390nH
L4331	2462587T09	33nH
L4333	2462587T22	390nH
L4361	2462587T22	390nH
L4371	2462587T13	68nH
L4401	2460591B04	11.03nH
L4402	2484657R01	57R01

Circuit Ref	Motorola Part No.	Description
L4403	2462587T11	47nH
L4411	2462587T11	47nH
L4421	2484657R01	57R01
L4422	2460591A29	6.61nH
L4436	2484657R01	57R01
L4437	2460592A01	17nH
L4471	2460591N36	43.67nH
L4472	2460592A01	17nH
L4491	2460592A01	17nH
L4492	2460592A01	17nH
L4493	2460592A01	17nH
M3421	2686201B01	HEATSINK
Q3101	4813827A07	NPN
Q3102	4813827A07	NPN
Q3141	4880214G02	NPN
Q3151	4880048M01	NPN
Q3152	4880048M01	NPN
Q4002	4813824A17	PNP
Q4003	4813827A07	NPN
Q4004	4805921T02	DUAL NPN/PNP
Q4221	4880048M01	NPN
Q4301	4805218N63	DIODE DUAL SCHOTTKY
Q4332	4813827A07	NPN
Q4333	4802245J50	DUAL NPN/PNP
Q4411	4805921T02	DUAL NPN/PNP
Q4421	4886212B01	RF Power LDMOS MRF 1518
Q4422	4880048M01	NPN
Q4441	4886136B01	RF Power LDMOS MRF 1535
Q4442	4880048M01	NPN
Q4471	4880048M01	NPN
Q4472	4805128M27	PNP
R3101	0662057A75	12K
R3102	0662057A01	10
R3105	0662057A25	100
R3106	0662057A83	27K
R3107	0662057A69	6.8K
R3108	0662057A44	620
R3111	0662057A75	12K
R3112	0662057A01	10
R3113	0662057A37	330
R3115	0662057A39	390
R3116	0662057A37	330
R3117	0662057A83	27K
R3118	0662057A69	6.8K
R3123	0662057B47	0
R3130	0662057A18	51
R3132	0662057A77	15K
R3133	0662057A71	8.2K
R3134	0662057A73	10K
R3135	0662057A51	1.2K
R3141	0662057A39	390

Circuit Ref	Motorola Part No.	Description
R3142	0662057A55	1.8K
R3144	0662057A58	2.4K
R3145	0662057A61	3.3K
R3146	0662057A45	680
R3147	0662057A75	12K
R3148	0662057B47	0
R3151	0662057A73	10K
R3152	0662057A73	10K
R3153	0662057A73	10K
R3154	0662057A73	10K
R4001	0662057A97	100K
R4002	0662057A37	330
R4003	0662057A63	3.9K
R4004	0662057A59	2.7K
R4005	0662057A73	10K
R4007	0662057A25	100
R4012	0662057A97	100K
R4013	0662057A35	270
R4014	0662057A01	10
R4016	0662057A61	3.3K
R4018	0662057A61	3.3K
R4022	0662057B47	0
R4051	0662057A18	51
R4052	0662057B47	0
R4060	0662057B10	330K
R4061	0662057A73	10K
R4062	0662057A53	1.5K
R4063	0662057A39	390
R4064	0662057A18	51
R4068	0662057A53	1.5K
R4069	0662057A49	1K
R4070	0662057A39	390
R4071	0662057A73	10K
R4072	0662057A73	10K
R4201	0662057A29	150
R4203	0662057A17	47
R4204	0662057A17	47
R4211	0662057B47	0
R4221	0662057A29	150
R4222	0662057A42	510
R4223	0662057A21	68
R4224	0662057A89	47K
R4225	0662057A89	47K
R4228	0662057A89	47K
R4241	0662057A33	220
R4251	0662057A87	39K
R4252	0662057A84	30K
R4261	0662057A89	47K
R4263	0662057A25	100
R4301	0662057A67	5.6K
R4302	0662057A73	10K

Circuit Ref	Motorola Part No.	Description
R4303	0662057A12	30
R4304	0662057A31	180
R4305	0662057A01	10
R4311	0662057A70	7.5K
R4312	0662057A67	5.6K
R4313	0662057A12	30
R4314	0662057A35	270
R4315	0662057B47	0
R4321	0662057A91	56K
R4322	0662057A73	10K
R4323	0662057A97	100K
R4331	0662057A09	22
R4341	0662057B47	0
R4342	0662057A57	2.2K
R4343	0662057A49	1K
R4344	0662057A01	10
R4346	0662057A73	10K
R4347	0662057B47	0
R4361	0662057A31	180
R4400	0662057A18	51
R4401	0662057A36	300
R4402	0662057A05	15
R4403	0662057A36	300
R4404	0662057A73	10K
R4406	0662057A81	22K
R4413	0662057A61	3.3K
R4415	0662057A18	51
R4416	0662057A18	51
R4418	0662057A81	22K
R4421	0662057A83	27K
R4422	0662057A58	2.4K
R4423	0662057A87	39K
R4424	0662057C13	2,7
R4425	0662057C13	2,7
R4426	0662057C13	2,7
R4427	0662057C13	2,7
R4428	0662057A58	2.4K
R4429	0662057A49	1K
R4431	0662057C51	100
R4432	0662057C51	100
R4441	0662057A87	39K
R4442	0662057A57	2.2K
R4443	0662057A87	39K
R4445	0662057A58	2.4K
R4446	0662057B47	0
R4452	0662057A59	2.7K
R4454	0662057A73	10K
R4455	0662057A97	100K
R4457	0683962T51	120
R4471	0662057A41	470
R4473	0680194M18	51

Circuit Ref	Motorola Part No.	Description
R4474	0680194M18	51
R4475	0662057A73	10K
R4491	0662057A73	10K
R4501	0662057A69	6.8K
R4502	0662057A97	100K
R4504	0662057A73	10K
R4505	0662057B09	300K
R4507	0662057A80	20K
R4508	0662057A97	100K
R4509	0662057A49	1K
R4511	0662057C27	10
R4513	0680195M18	51
R4514	0680195M18	51
SH4301	2602641Y02	SHIELD
SH4302	2602641Y02	SHIELD
T4051	2505515V03	XFMR
T4052	2505515V04	XFMR
U3101	5186144B01	IC, IF
U3111	5102463J52	QUAD ANALOG SWITCH
U3115	5102463J52	QUAD ANALOG SWITCH
U4201	5185963A27	IC FRACTN
U4211	5185963A33	IC, VOLTAGE REGULATOR
U4301	5105750U54	IC, VCO
U4401	5185130C65	IC LDMOS DRIVER
U4402	5113818A01	Dual Op-Amp
U4501	5185765B28	IC POWER CONTROL
U4502	5185963A15	IC TEMPERATURE SENSOR
VR4471	4813830A15	DIODE, 5.6V
Y3101	4880606B09	2ND OSC XTAL 44.395 MHZ
Y3102	9186145B02	455KHz DISCRIMINATOR
* Y4261	Not Used	16.8MHz 75Z04
Y4262	4886182B01	TCXO 16.8MHZ

* Motorola Depot Servicing only

Reference designators with an asterisk indicate components which are not fieldreplaceable because they need to be calibrated with specialized factory equipment after installation. Radios in which these parts have been replaced in the field will be off frequency at temperature extremes.

3.0 UHF 25-40W PCB 8480643z06 / Schematic

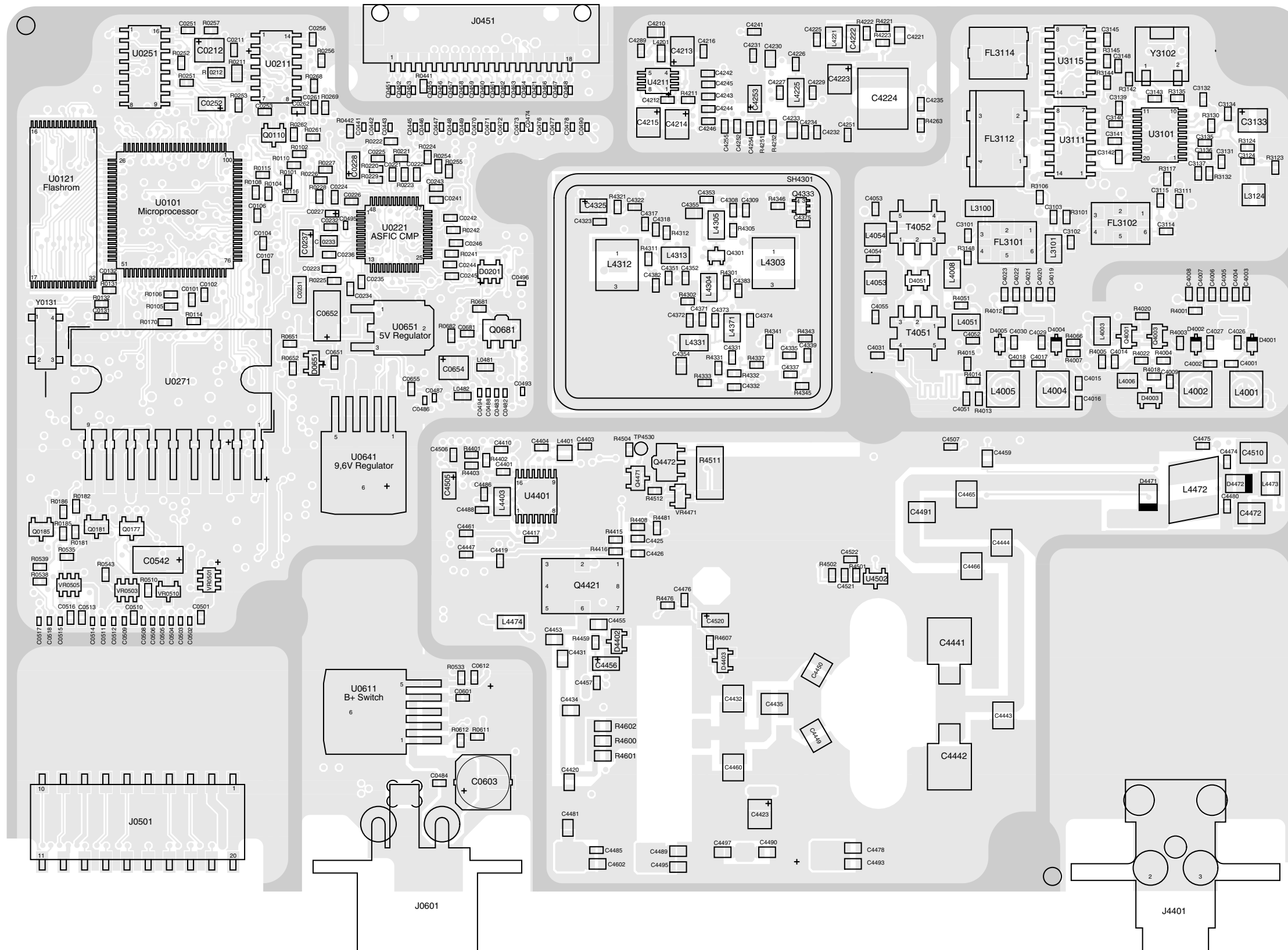

ZWG0130268-A

**UHF (403-470MHz) 25-40W
8480643z06 Top Side**

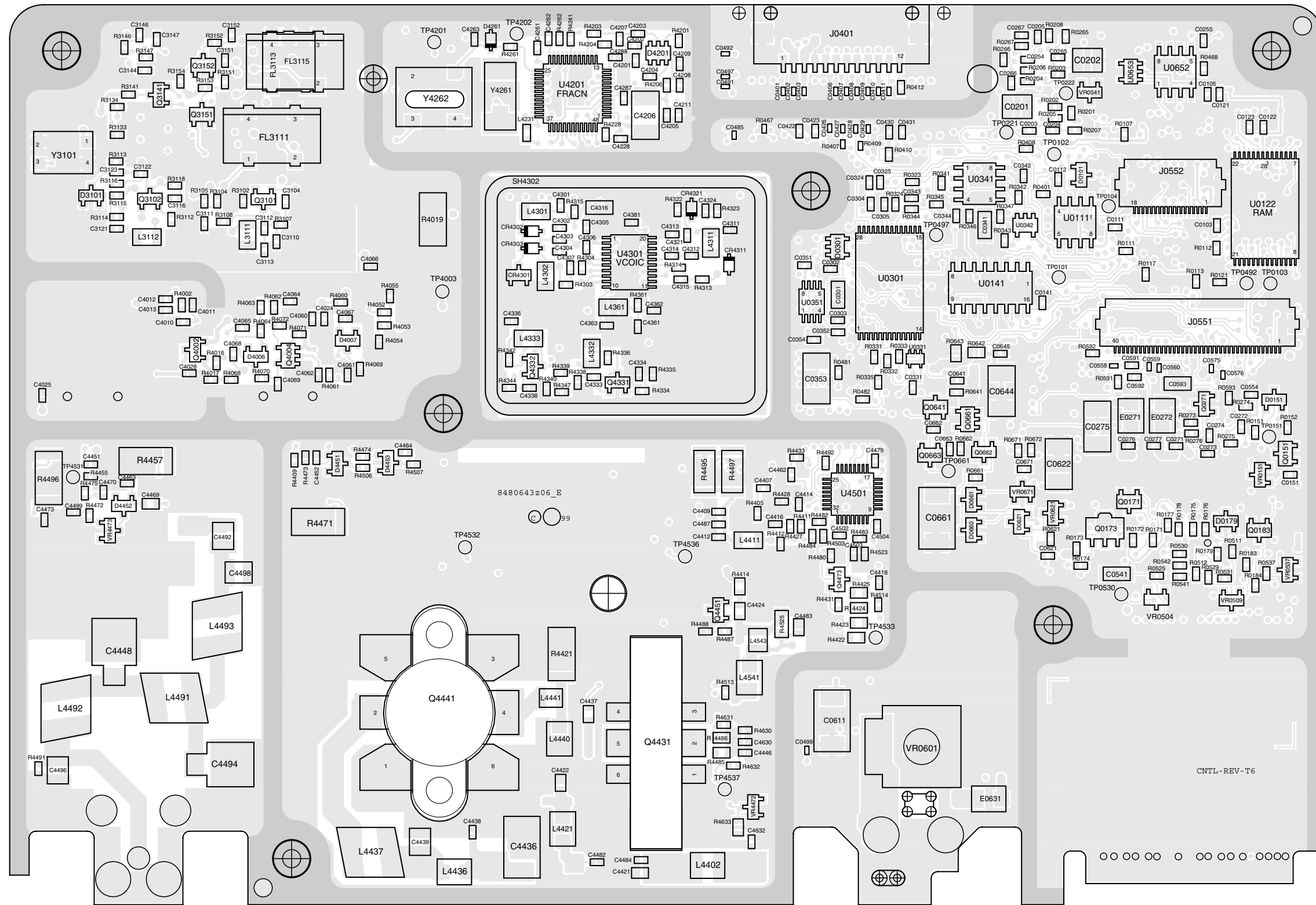

ZWG0130267-A

UHF (403-470MHz) 25-40W 8480643z06 Bottom Side

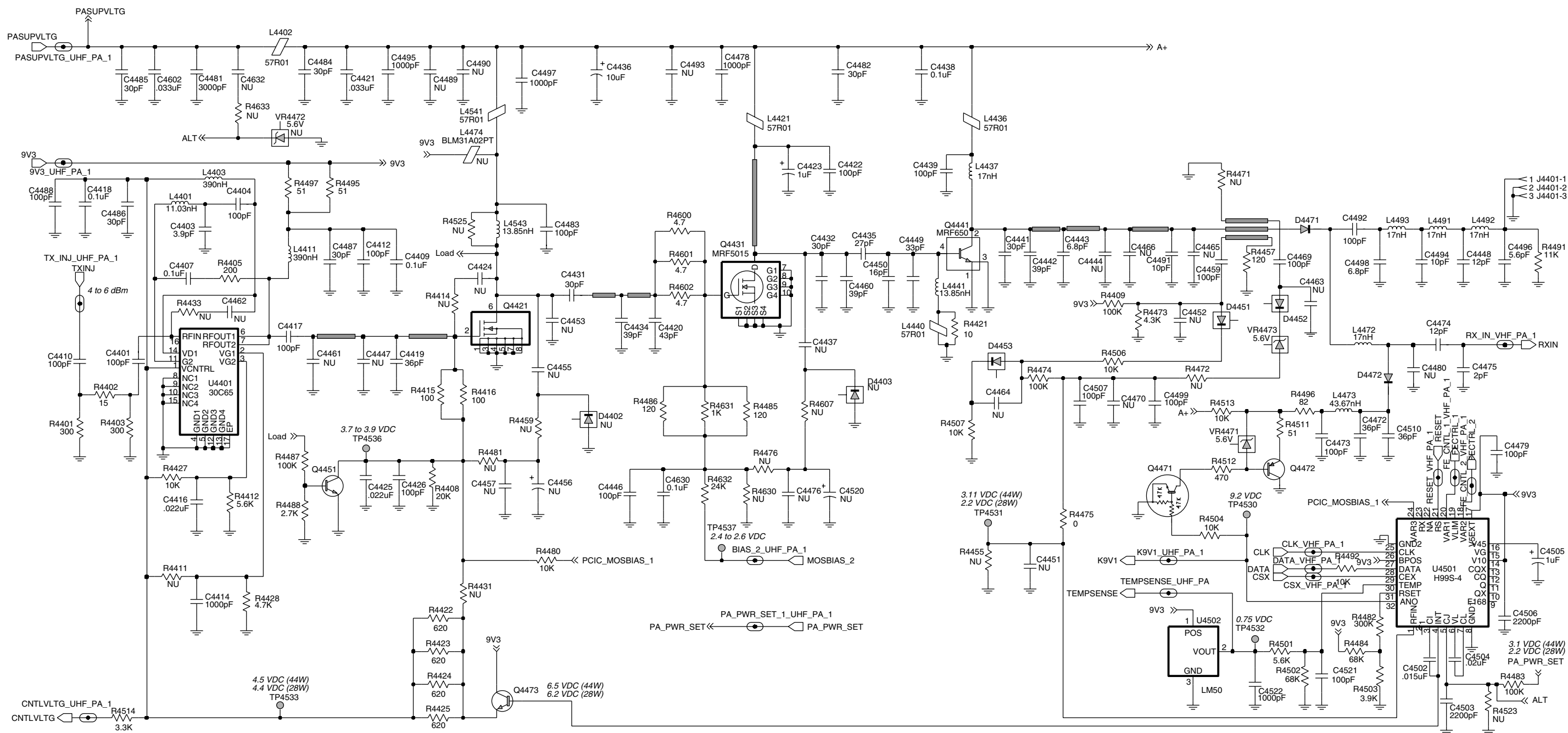

ZWG0130271-A

UHF (403-470MHz) Power Amplifier 25-40W

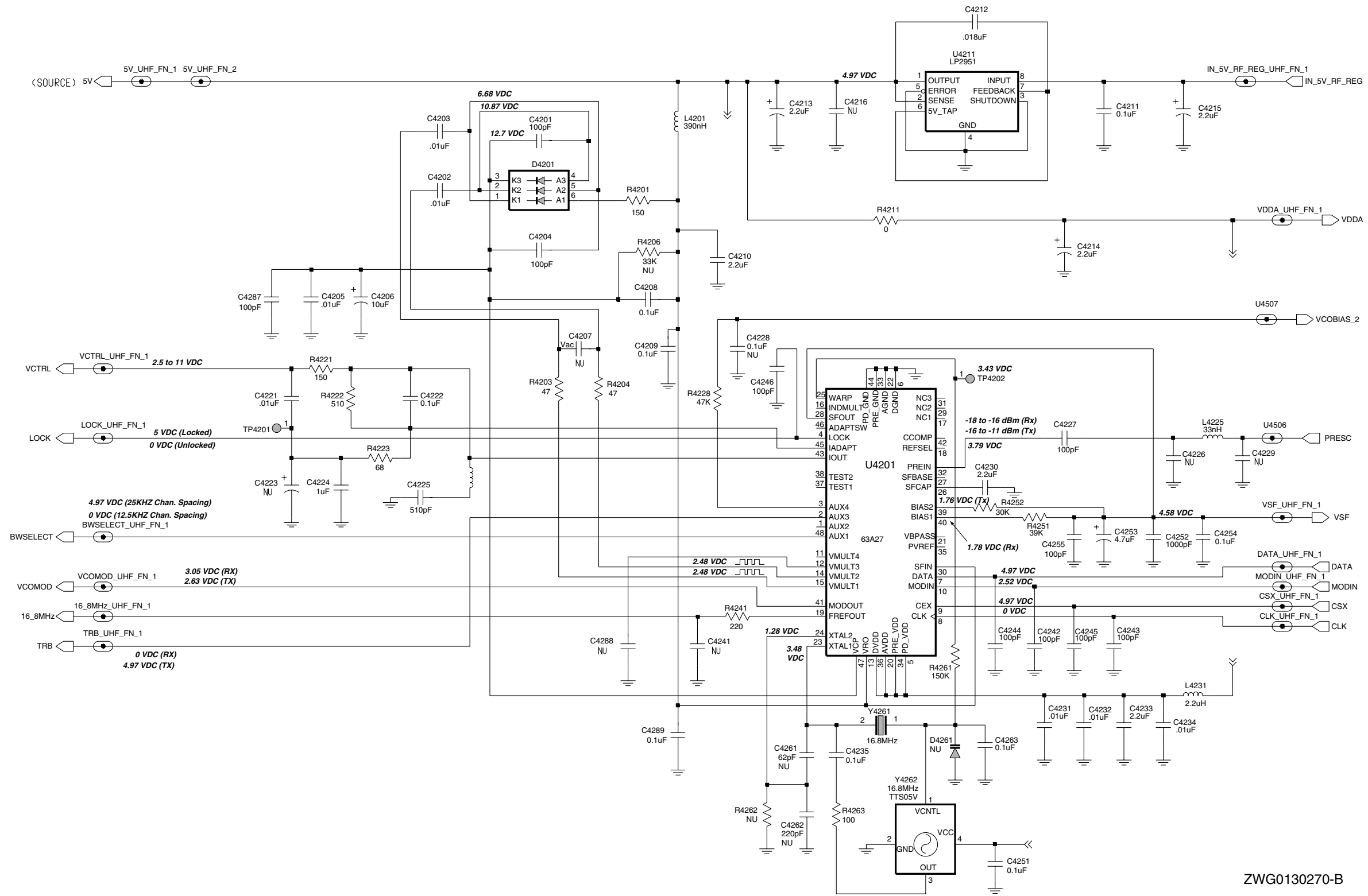

ZWG0130270-B

UHF (403-470MHz) FRACN

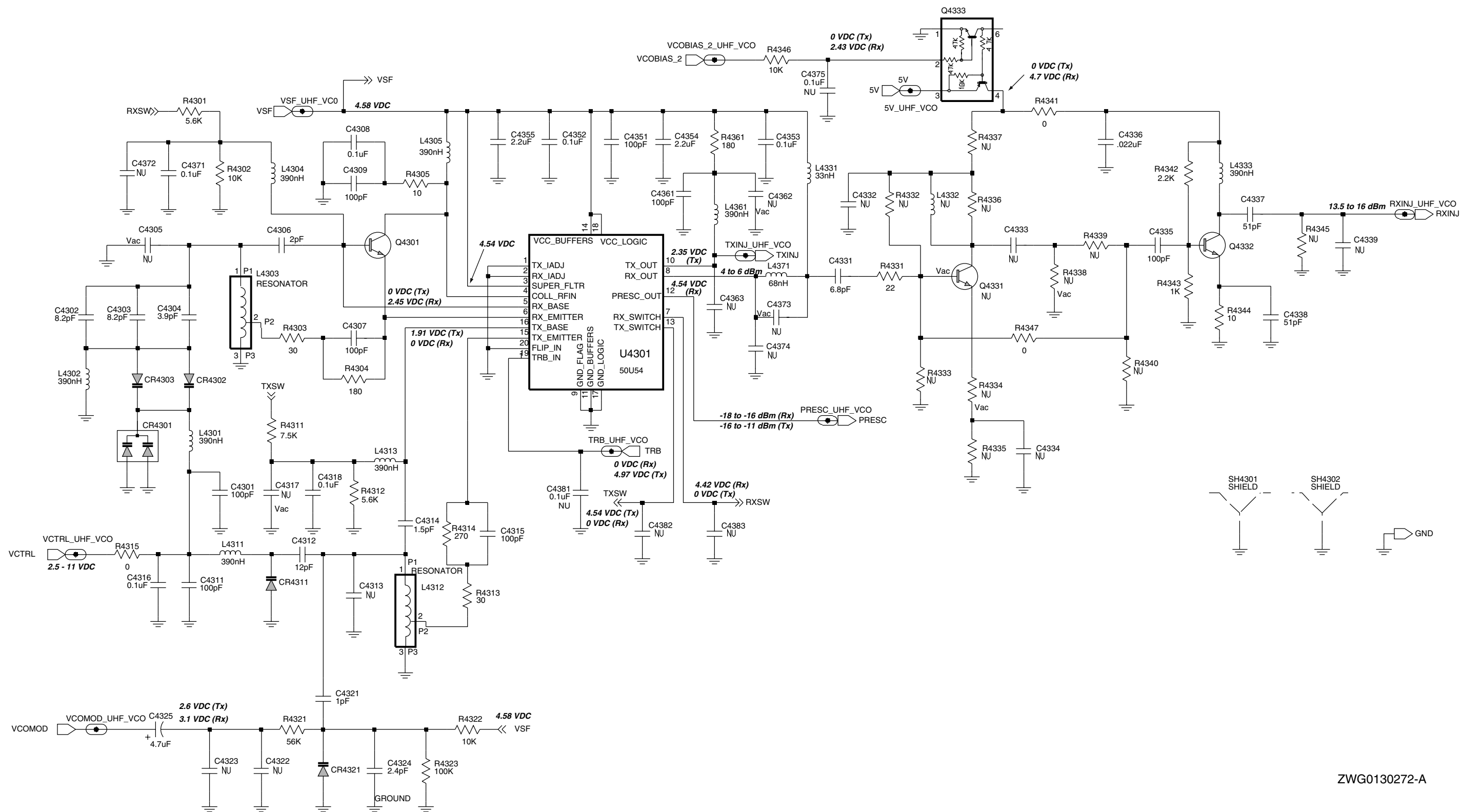

ZWG0130272-A

UHF (403-470MHz) VCO

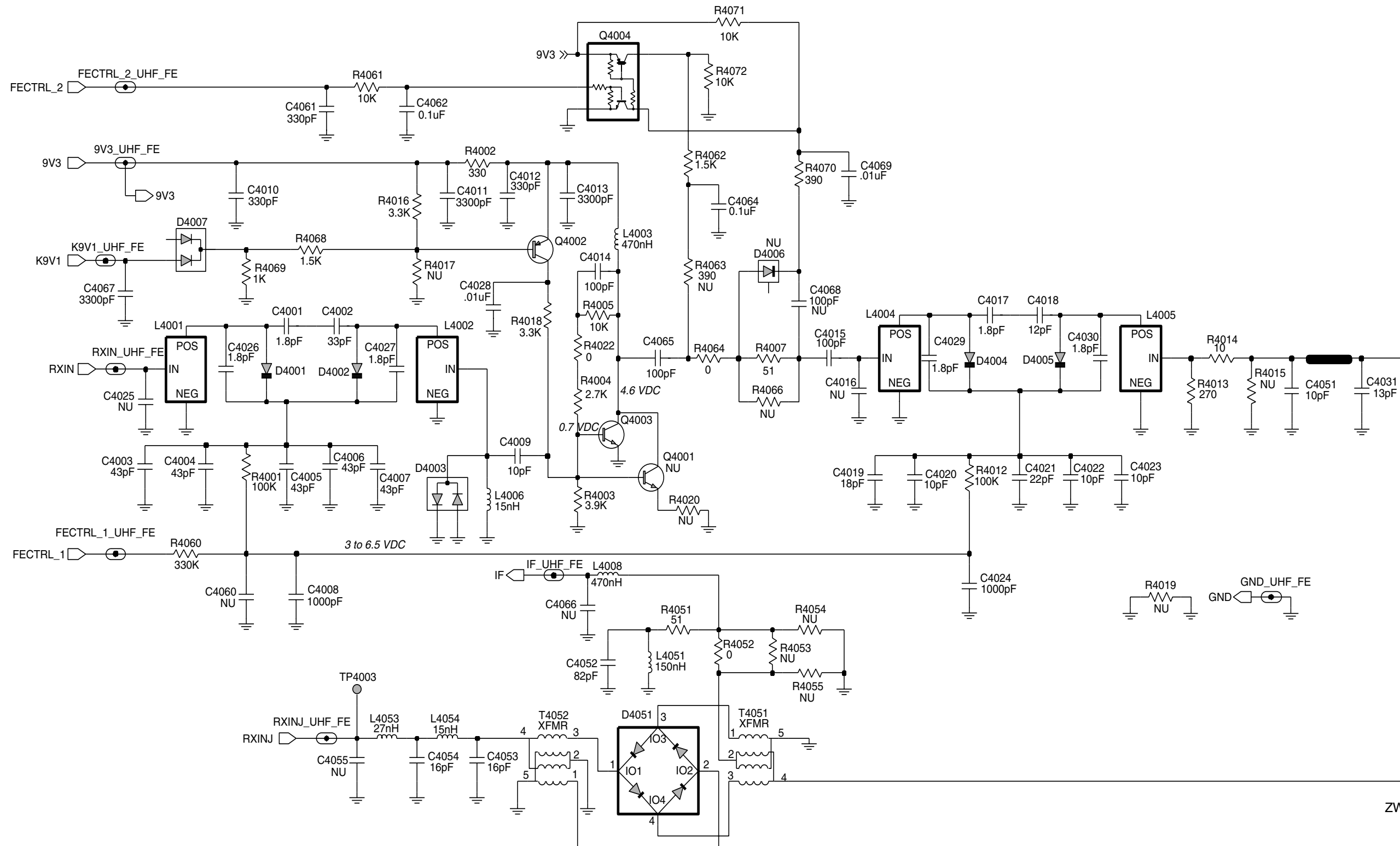

ZWG0130269-A

UHF (403-470MHz) Receiver Front End

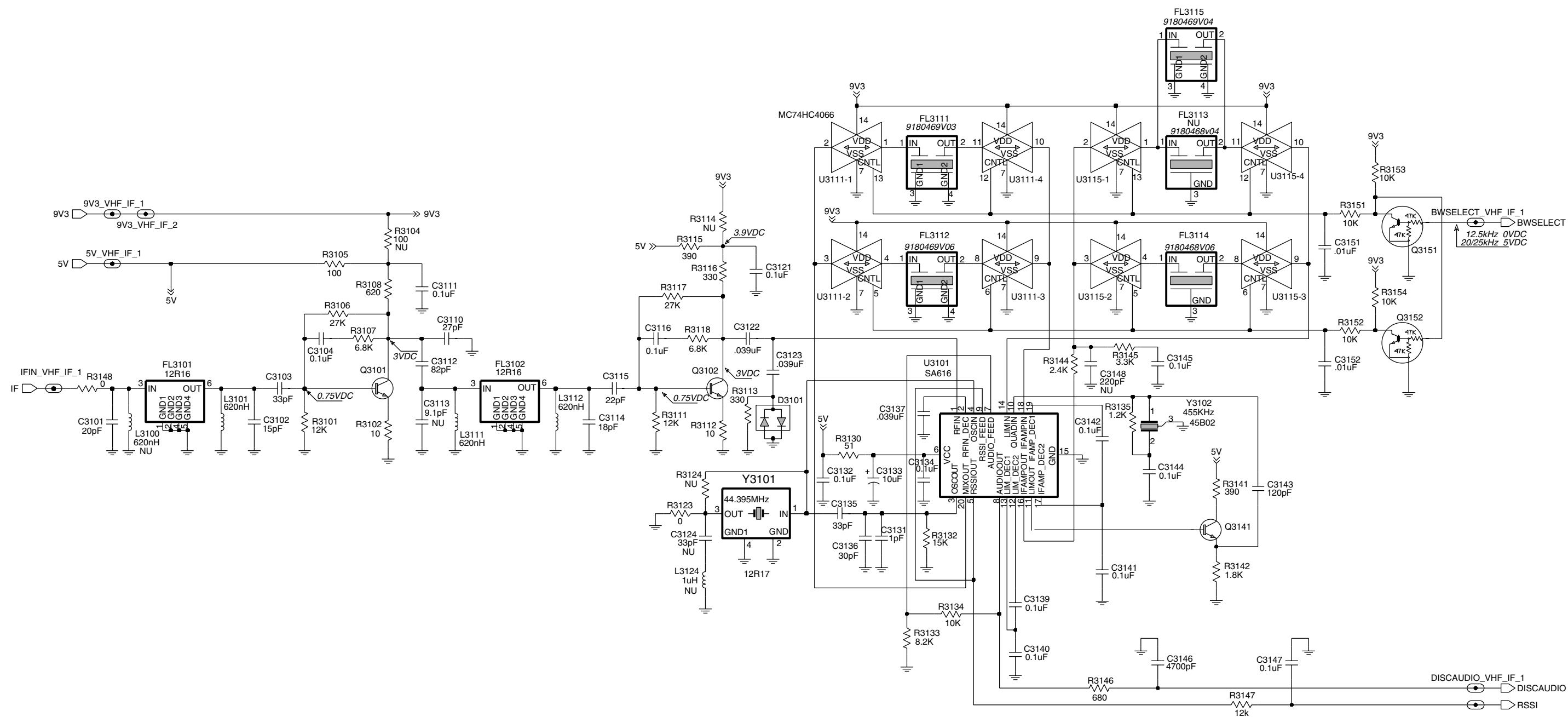

ZWG0130236-B

UHF (403-470MHz) IF

3.1 UHF PCB 8480643z06, 25-40W PartsList

Circuit Ref	Motorola Part No	Description
C3101	2113740F34	20pF
C3102	2113740F31	15pF
C3103	2113740F39	33pF
C3104	2113743E20	100nF
C3110	2113740F37	27pF
C3111	2113743E20	100nF
C3112	2113740F49	82pF
C3114	2113740F33	18pF
C3115	2113740F35	22pF
C3116	2113743E20	100nF
C3121	2113743E20	100nF
C3122	2113743E11	0.039uF
C3123	2113743E11	0.039uF
C3132	2113743E20	100nF
C3133	2311049A57	10uF
C3134	2113743E20	100nF
C3135	2113740L30	33pF
C3136	2113740L29	30pF
C3137	2113743E11	0.039uF
C3139	2113743E20	100nF
C3140	2113743E20	100nF
C3141	2113743E20	100nF
C3142	2113743E20	100nF
C3143	2113740F53	120pF
C3144	2113743E20	100nF
C3145	2113743E20	100nF
C3146	2113741F41	4700pF
C3147	2113743E20	100nF
C3151	2113741F49	10nF
C3152	2113741F49	10nF
C4001	2113740F09	1.8pF
C4002	2113740F39	33pF
C4003	2113740F42	43pF
C4004	2113740F42	43pF
C4005	2113740F42	43pF
C4006	2113740F42	43pF
C4007	2113740F42	43pF
C4008	2113741F25	1000pF
C4009	2113740F27	10pF
C4010	2113741F13	330pF
C4011	2113741F37	3300pF
C4012	2113741F13	330pF
C4013	2113741F37	3300pF
C4014	2113740F51	100pF
C4015	2113740F51	100pF
C4017	2113740F09	1.8pF
C4018	2113740F29	12pF
C4019	2113740F33	18pF
C4020	2113740F27	10pF
C4021	2113740F35	22pF

Circuit Ref	Motorola Part No	Description
C4022	2113740F27	10pF
C4023	2113740F27	10pF
C4024	2113741F25	1000pF
C4026	2113740F09	1.8pF
C4027	2113740F09	1.8pF
C4028	2113741F49	10nF
C4029	2113740F09	1.8pF
C4030	2113740F09	1.8pF
C4031	2113740F30	13pF
C4051	2113740F27	10pF
C4052	2113740F49	82pF
C4053	2113740F32	16pF
C4054	2113740F32	16pF
C4061	2113740F63	330pF
C4062	2113743E20	100nF
C4064	2113743E20	100nF
C4065	2113740F51	100pF
C4067	2113741F37	3300pF
C4069	2113741F49	10nF
C4201	2113740F51	100pF
C4202	2113741F49	10nF
C4203	2113741F49	10nF
C4204	2113740F51	100pF
C4205	2113741F49	10nF
C4206	2311049J25	10uF
C4208	2113743E20	100nF
C4209	2113743E20	100nF
C4210	2104993J02	2.2uF
C4211	2113743E20	100nF
C4212	2113743E05	0.018uF
C4213	2311049A09	2.2uF
C4214	2311049A09	2.2uF
C4215	2311049A09	2.2uF
C4221	2109720D01	0.01uF
C4222	2109720D14	0.01uF
C4224	0882422W23	1uF
C4225	2113741F18	510pF
C4227	2113740F51	100pF
C4230	2104993J02	2.2uF
C4231	2113741F49	10nF
C4232	2113741F49	10nF
C4233	2104993J02	2.2uF
C4234	2113741F49	10nF
C4235	2113741F49	10nF
C4242	2113740F51	100pF
C4243	2113740F51	100pF
C4244	2113740F51	100pF
C4245	2113740F51	100pF
C4246	2113740F51	100pF
C4251	2113743E20	100nF
C4252	2113741F25	1000pF

Circuit Ref	Motorola Part No	Description
C4253	2311049A56	4.7uF
C4254	2113743E20	100nF
C4255	2113740F51	100pF
C4263	2113743E20	100nF
C4287	2113740F51	100pF
C4289	2113743E20	100nF
C4301	2113740F51	100pF
C4302	2113740L16	8.2 pF
C4303	2113740L16	8.2 pF
C4304	2113740L08	3.9pF
C4306	2113740L01	2pF
C4307	2113740F51	100pF
C4308	2113743E20	100nF
C4309	2113740F51	100pF
C4311	2113740F51	100pF
C4312	2113740F29	12pF
C4314	2113740F07	1.5pF
C4315	2113740F51	100pF
C4316	2109720D14	0.01uF
C4318	2113743E20	100nF
C4321	2113740F03	1pF
C4324	2113740L03	2.4pF
C4325	2311049A56	4.7uF
C4331	2113740L14	6.8pF
C4335	2113740F51	100pF
C4336	2113743E07	0.022uF
C4337	2113740F44	51pF
C4338	2113740F44	51pF
C4351	2113740F51	100pF
C4352	2113743E20	100nF
C4353	2113743E20	100nF
C4354	2104993J02	2.2uF
C4355	2104993J02	2.2uF
C4361	2113740F51	100pF
C4371	2113743E20	100nF
C4401	2113740F51	100pF
C4403	2113740F17	3.9pF
C4404	2113740F51	100pF
C4407	2113743E20	100nF
C4409	2113743E20	100nF
C4410	2113740F51	100pF
C4412	2113740F51	100pF
C4414	2113741F25	1000pF
C4416	2113743E07	0.022uF
C4417	2113740F51	100pF
C4418	2113743E20	100nF
C4419	2113740F40	36pF
C4420	2113740A44	43pF
C4421	2113741A57	0.033uF
C4422	2113740A55	100pF
C4423	2311049A08	1uF

Circuit Ref	Motorola Part No	Description
C4425	2113743E07	0.022uF
C4426	2113740F51	100pF
C4431	2113740A40	30pF
C4432	2111078B27	30pF
C4435	2111078B25	27pF
C4436	2311049A45	10uF
C4438	2113743E20	100nF
C4439	2111078B42	100pF
C4441	2180464E40	30pF
C4442	2180464E34	39pF
C4443	2111078B09	6.8pF
C4446	2113740F51	100pF
C4448	2180464E65	12pF
C4449	2111078B29	33pF
C4450	2111078B19	16pF
C4459	2113740A55	100pF
C4460	2111078B32	39pF
C4469	2113740A55	100pF
C4472	2111078B31	43pF
C4473	2113740F51	100pF
C4474	2113740F29	12pF
C4475	2113740F10	2pF
C4478	2113741A21	1000pF
C4479	2113740F51	100pF
C4481	2113741A32	3000pF
C4482	2113740F38	30pF
C4483	2113740A55	100pF
C4484	2113740F38	30pF
C4485	2113740F38	30pF
C4486	2113740F38	30pF
C4487	2113740F38	30pF
C4488	2113740F51	100pF
C4491	2111078B13	10pF
C4492	2111078B42	100pF
C4494	2180464E63	10pF
C4495	2113741A21	1000pF
C4496	2111078B07	5.6pF
C4497	2113741A21	1000pF
C4498	2111078B09	6.8pF
C4499	2113740F51	100pF
C4502	2113743E03	0.015uF
C4503	2113741F33	2200pF
C4504	2113743E06	0.020uF
C4505	2311049A07	1uF
C4506	2113741F33	2200pF
C4507	2113740F51	100pF
C4510	2111078B31	43pF
C4521	2113740F51	100pF
C4522	2113741F25	1000pF
C4602	2113741A57	0.033uF
C4630	2113743E20	100nF

Circuit Ref	Motorola Part No	Description
C4632	2113741F25	1000pF
CR4301	4805649Q13	DIODE, VARACTOR
CR4302	4862824C01	DIODE VARACTOR
CR4303	4862824C01	DIODE VARACTOR
CR4311	4802245J22	DIODE, VARACTOR
CR4321	4862824C01	DIODE VARACTOR
D3101	4880154K03	DIODE DUAL SCHOTTKY
D4001	4862824C01	DIODE VARACTOR
D4002	4862824C01	DIODE VARACTOR
D4003	4880154K03	DIODE DUAL SCHOTTKY
D4004	4862824C01	DIODE VARACTOR
D4005	4862824C01	DIODE VARACTOR
D4007	4813833C02	DIODE, DUAL 70V
D4051	4886143B01	DIODE, MIXER
D4201	4802233J09	DIODE, TRIPLE
D4451	4813825A05	DIODE
D4452	4813825A05	DIODE
D4453	4813825A05	DIODE
D4471	4802482J02	DIODE
D4472	4802482J02	DIODE
FL3101	9180112R16	2 POLE 44.85 MHZ XSTAL
FL3102	9180112R16	2 POLE 44.85 MHZ XSTAL
FL3111	9180469V03	CERAMIC FILTER, 455KHz
FL3112	9180469V06	CERAMIC FILTER, 455KHz
FL3114	9180468V06	CERAMIC FILTER, 455KHz
FL3115	9180469V04	CERAMIC FILTER, 455KHz
L3101	2462587T25	620nH
L3111	2462587T25	620nH
L3112	2462587T25	620nH
L4003	2462587T23	470nH
L4006	2462587V24	15nH
L4008	2462587T23	470nH
L4051	2462587T17	150nH
L4053	2462587N46	27nH
L4054	2462587N43	15nH
L4201	2462587Q42	390nH
L4221	2462587P25	12uH
L4225	2462587T40	33nH
L4231	2462587Q20	2.2uH
L4301	2462587T22	390nH
L4302	2462587T22	390nH
L4303	2460593C01	RESONATOR
L4304	2462587T22	390nH
L4305	2462587T22	390nH
L4311	2462587T22	390nH
L4312	2460593C01	RESONATOR
L4313	2462587T22	390nH
L4331	2462587T09	33nH
L4333	2462587T22	390nH
L4361	2462587T22	390nH
L4371	2462587T13	68nH

Circuit Ref	Motorola Part No	Description
L4401	2460591B04	11.03nH
L4402	2484657R01	Ferrite Bead
L4403	2462587T22	390nH
L4411	2462587T22	390nH
L4421	2484657R01	Ferrite Bead
L4436	2484657R01	Ferrite Bead
L4437	2460592A01	17nH
L4440	2484657R01	Ferrite Bead
L4441	2460591C23	13.85nH
L4472	2460592A01	17nH
L4473	2460591N36	43.67nH
L4491	2460592A01	17nH
L4492	2460592A01	17nH
L4493	2460592A01	17nH
L4541	2484657R01	Ferrite Bead
L4543	2460591C23	13.85nH
Q3101	4813827A07	NPN
Q3102	4813827A07	NPN
Q3141	4880214G02	NPN
Q3151	4880048M01	NPN
Q3152	4880048M01	NPN
Q4002	4813824A17	PNP
Q4003	4813827A07	NPN
Q4004	4805921T02	DUAL NPN/PNP
Q4301	4805218N63	DIODE DUAL SCHOTTKY
Q4332	4813827A07	NPN
Q4333	4802245J50	DUAL NPN/PNP
Q4421	5105385Y91	POWER AMPLIFIER
Q4431	4805537W01	Bipolar Power Amplifier
Q4441	4880225C30	Bipolar power Amplifier
Q4451	4880214G02	NPN
Q4471	4880048M01	NPN
Q4472	4805128M27	PNP
Q4473	4880214G02	NPN
R3101	0662057A75	12K
R3102	0662057A01	10
R3105	0662057A25	100
R3106	0662057A83	27K
R3107	0662057A69	6800
R3108	0662057A44	620
R3111	0662057A75	12K
R3112	0662057A01	10
R3113	0662057A37	330
R3115	0662057A39	390
R3116	0662057A37	330
R3117	0662057A83	27K
R3118	0662057A69	6800
R3130	0662057A18	51
R3132	0662057A77	15K
R3133	0662057A71	8200
R3134	0662057A73	10K

Circuit Ref	Motorola Part No	Description
R3135	0662057A51	1200
R3141	0662057A39	390
R3142	0662057A55	1800
R3144	0662057A58	2400
R3145	0662057A61	3300
R3146	0662057A45	680
R3147	0662057A75	12K
R3148	0662057B47	0
R3151	0662057A73	10K
R3152	0662057A73	10K
R3153	0662057A73	10K
R3154	0662057A73	10K
R4001	0662057A97	100K
R4002	0662057A37	330
R4003	0662057A63	3900
R4004	0662057A59	2700
R4005	0662057A73	10K
R4007	0662057A18	51
R4012	0662057A97	100K
R4013	0662057A35	270
R4014	0662057A01	10
R4016	0662057A61	3300
R4018	0662057A61	3300
R4022	0662057B47	0
R4051	0662057A18	51
R4052	0662057B47	0
R4060	0662057B10	330K
R4061	0662057A73	10K
R4062	0662057A53	1500
R4064	0662057B47	0
R4068	0662057A53	1500
R4069	0662057A49	1000
R4070	0662057A39	390
R4071	0662057A73	10K
R4072	0662057A73	10K
R4201	0662057A29	150
R4203	0662057A17	47
R4204	0662057A17	47
R4211	0662057B47	0
R4221	0662057A29	150
R4222	0662057A42	510
R4223	0662057A21	68
R4228	0662057A89	47K
R4241	0662057A33	220
R4251	0662057A87	39K
R4252	0662057A84	30K
R4261	0662057A89	47K
R4263	0662057A25	100
R4301	0662057A67	5600
R4302	0662057A73	10K
R4303	0662057A12	30

Circuit Ref	Motorola Part No	Description
R4304	0662057A31	180
R4305	0662057A01	10
R4311	0662057A70	7500
R4312	0662057A67	5600
R4313	0662057A12	30
R4314	0662057A35	270
R4315	0662057B47	0
R4321	0662057A91	56K
R4322	0662057A73	10K
R4323	0662057A97	100K
R4331	0662057A09	22
R4341	0662057B47	0
R4342	0662057A57	2200
R4343	0662057A49	1000
R4344	0662057A01	10
R4346	0662057A73	10K
R4347	0662057B47	0
R4361	0662057A31	180
R4401	0662057A36	300
R4402	0662057A05	15
R4403	0662057A36	300
R4405	0662057A32	200
R4408	0662057A80	20K
R4409	0662057A97	100K
R4412	0662057A67	5600
R4415	0662057A25	100
R4416	0662057A25	100
R4421	0680194M01	10
R4422	0611079A69	620
R4423	0611079A69	620
R4424	0611079A69	620
R4425	0611079A69	620
R4427	0662057A73	10K
R4428	0662057A65	4300
R4457	0683962T51	120
R4473	0662057A64	4300
R4474	0662057A97	100K
R4475	0662057B47	0
R4480	0662057A73	10K
R4482	0662057B09	300K
R4483	0662057A97	100K
R4484	0662057A93	68K
R4485	0662057C53	120
R4486	0662057C53	120
R4487	0662057A97	100K
R4488	0662057A59	2700
R4491	0662057A74	11K
R4492	0662057A73	10K
R4495	0680195M18	51
R4496	0680194M23	82
R4497	0680195M18	51

Circuit Ref	Motorola Part No	Description
R4501	0662057A67	5600
R4502	0662057A93	68K
R4503	0662057A63	3900
R4504	0662057A73	10K
R4506	0662057A73	10K
R4507	0662057A73	10K
R4511	0680194M18	51
R4512	0662057A41	470
R4513	0662057A73	10K
R4514	0662057A61	3300
R4600	0662057C19	4.7
R4601	0662057C19	4.7
R4602	0662057C19	4.7
R4631	0662057A49	1000
R4632	0662057A82	24K
SH4301	2602641Y02	SHIELD
SH4302	2602641Y02	SHIELD
T4051	2505515V03	XFMR MIXER 4:1
T4052	2505515V04	XMFR MIXER 5:1
U3101	5186144B01	IC, IF
U3111	5102463J52	QUAD ANALOG SWITCH
U3115	5102463J52	QUAD ANALOG SWITCH
U4201	5185963A27	IC FRACTN
U4211	5185963A33	IC, VOLTAGE REGULATOR
U4301	5105750U54	IC, VCO
U4401	5105109Z67	IC LDMOS DRIVER
U4501	5185765B28	IC POWER CONTROL
U4502	5185963A15	IC TEMPERATURE SENSOR
VR4471	4813830A15	DIODE, 5.6V
VR4473	4813830A15	DIODE, 5.6V
Y3101	4880606B09	2ND OSC XTAL 44.395 MHZ
Y3102	9186145B02	455KHz DISCRIMINATOR
Y4262	4886182B01	TCXO 16.8MHZ

* Motorola Depot Servicing only

Reference designators with an asterisk indicate components which are not fieldreplaceable because they need to be calibrated with specialized factory equipment after installation. Radios in which these parts have been replaced in the field will be off frequency at temperature extremes.

4.0 UHF 1-25W Band1 PCB 8485670z03 / Schematics

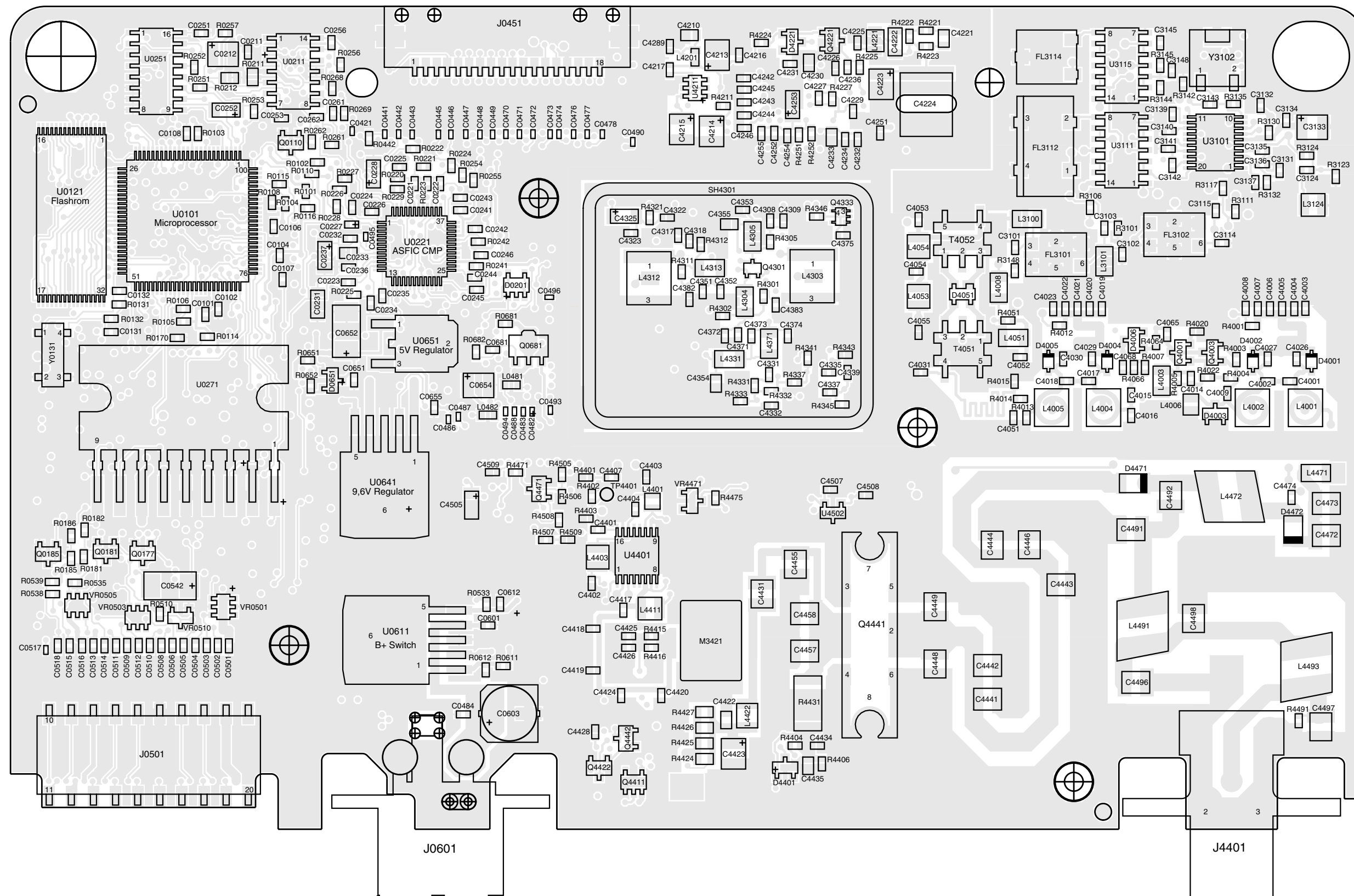

ZWG0130626-O

**UHF 1-25W
8485670z03 Top Side**

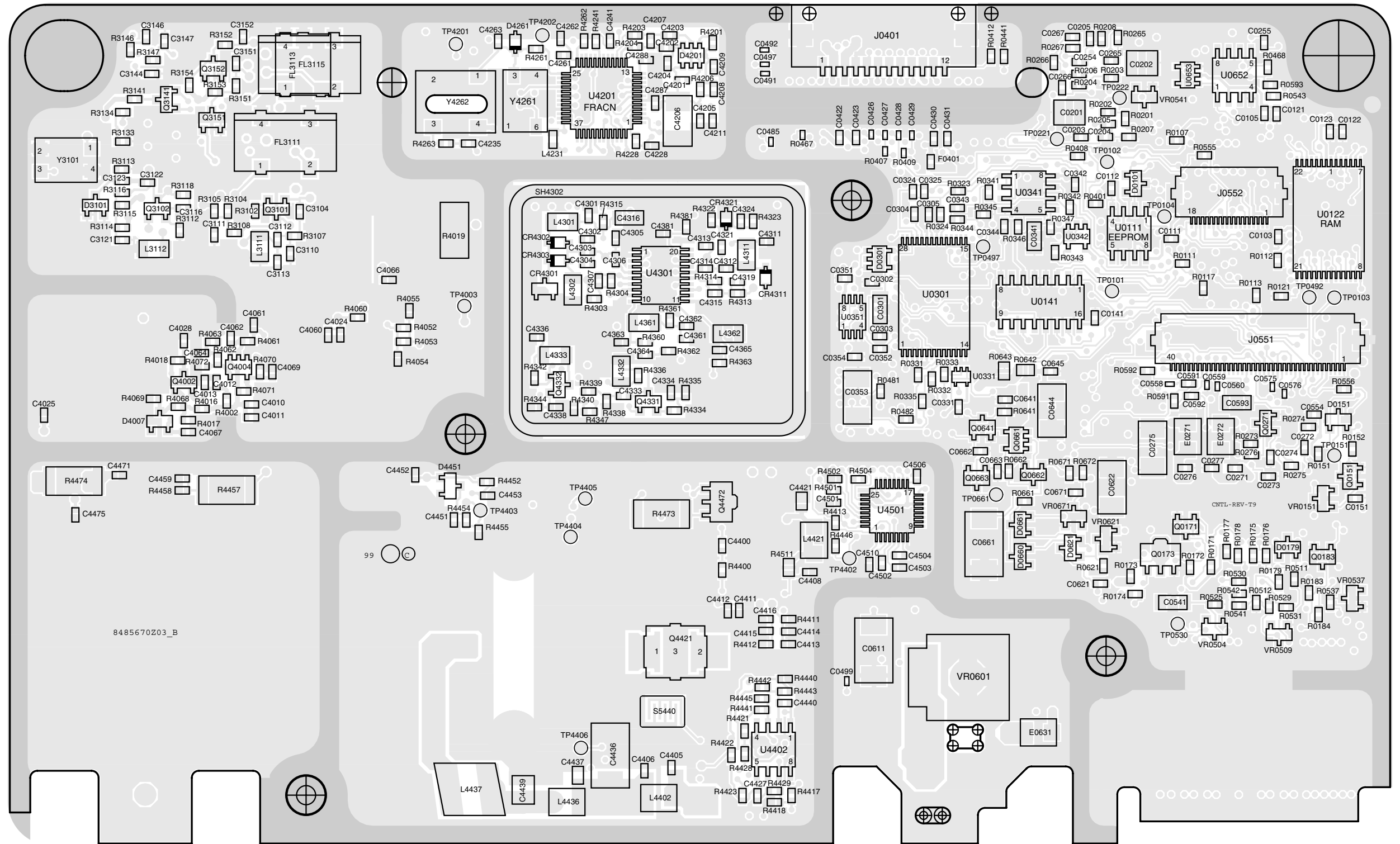

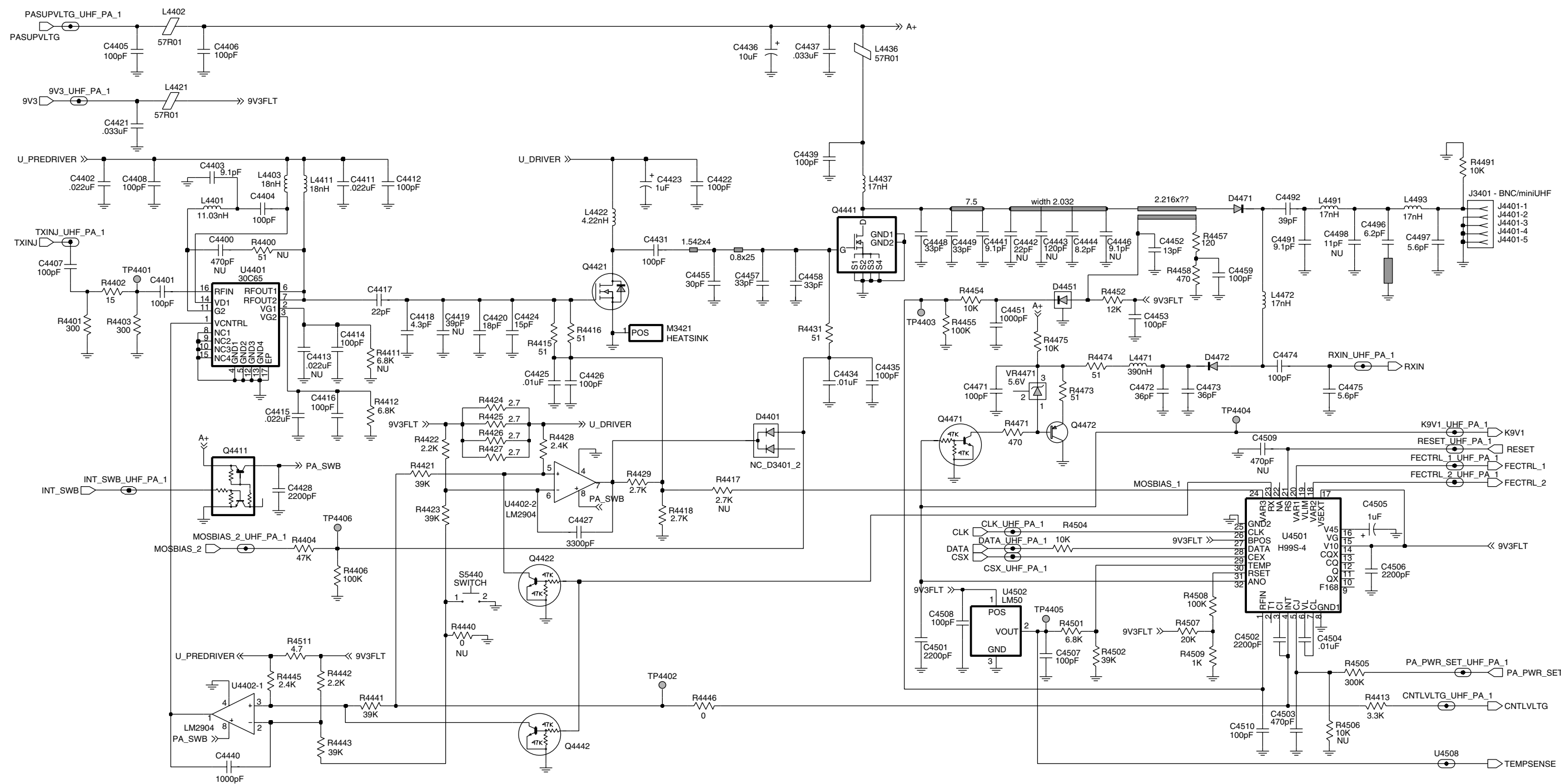

ZWG0130621-O

UHF (403-470 MHz) Power Amplifier

ZWG0130621-O

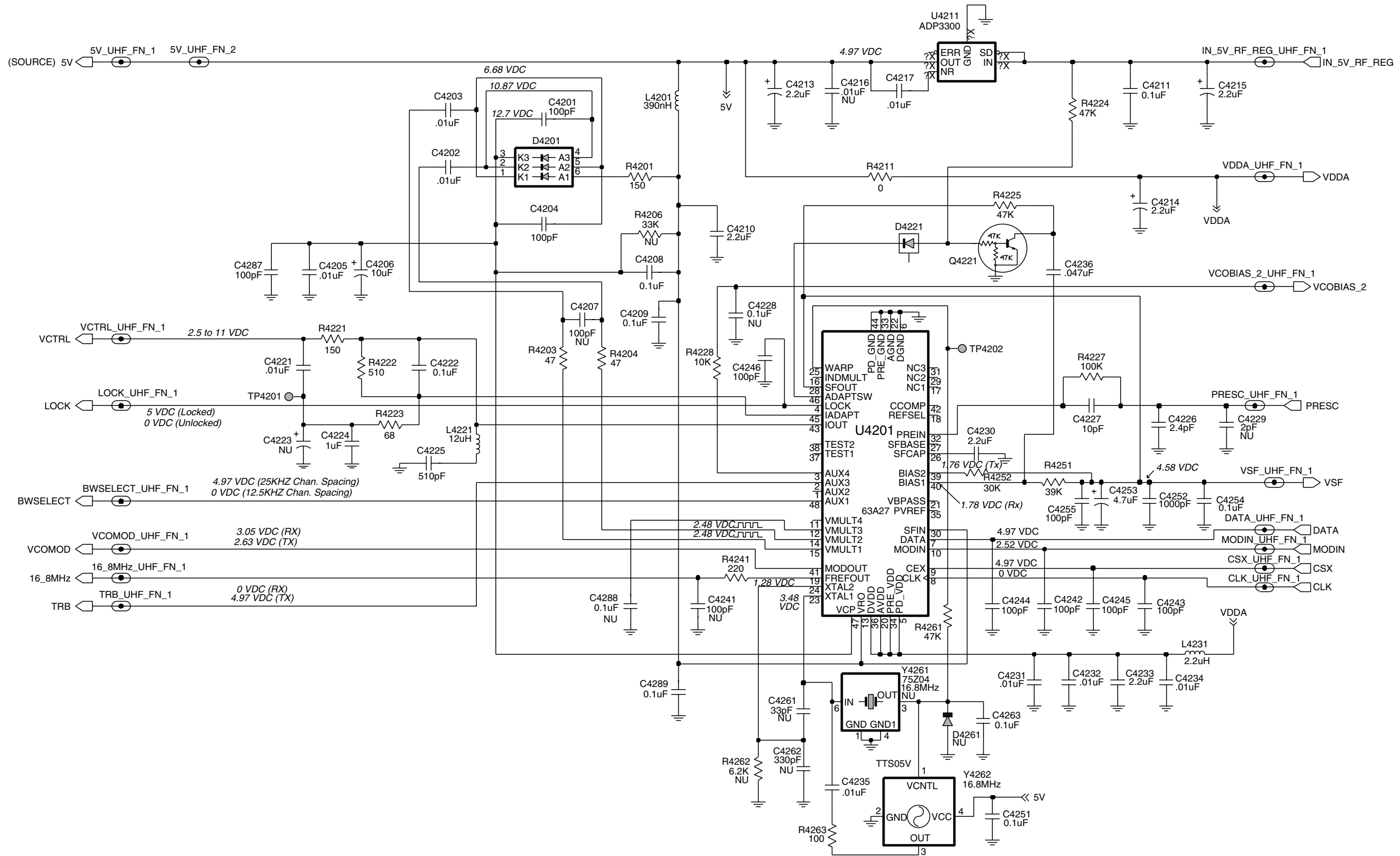

ZWG0130622-O

UHF (403-470 MHz) FRACN

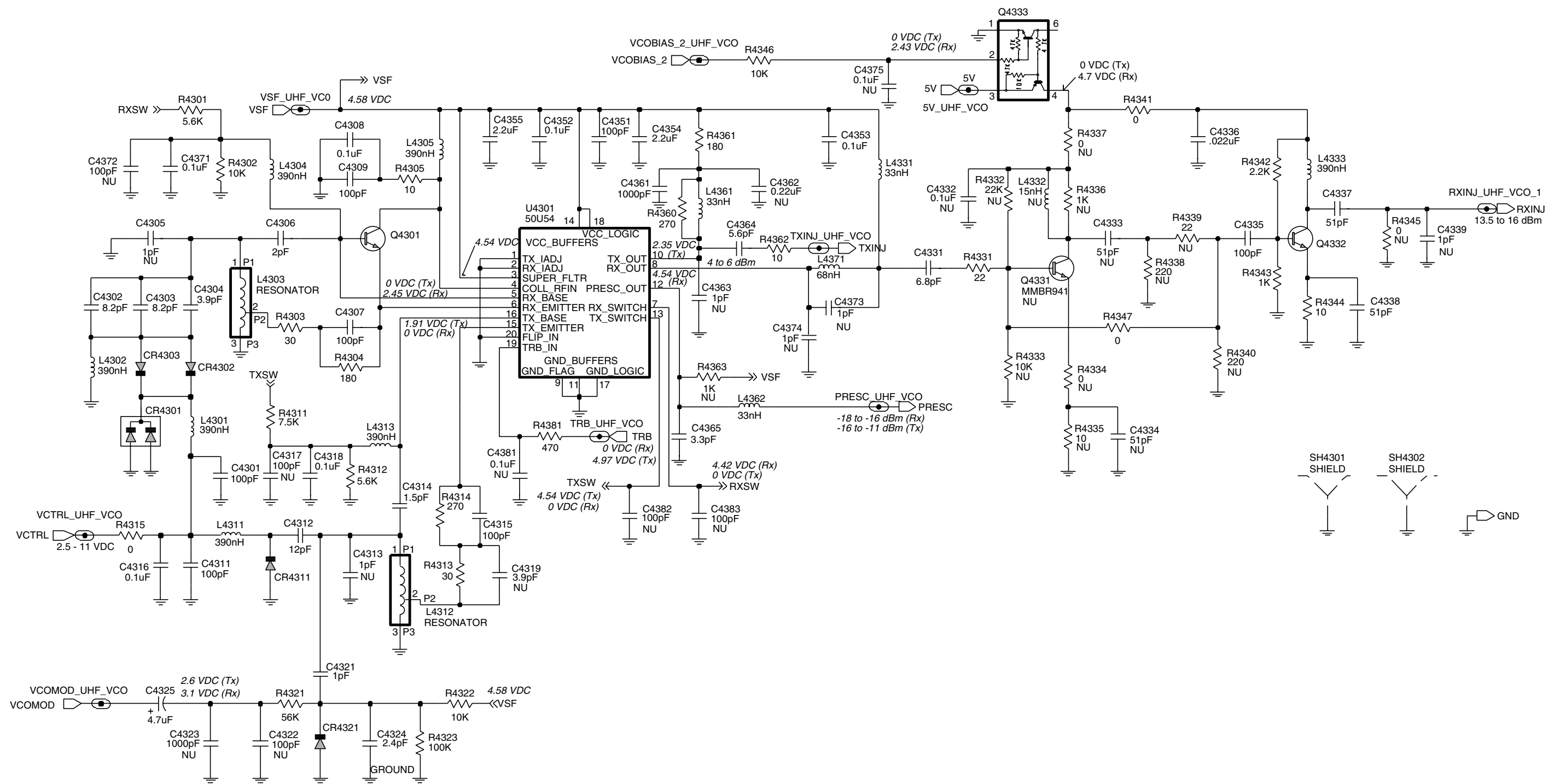

ZWG0130624-O

UHF (403-470 MHz) Voltage Controlled Oscillator

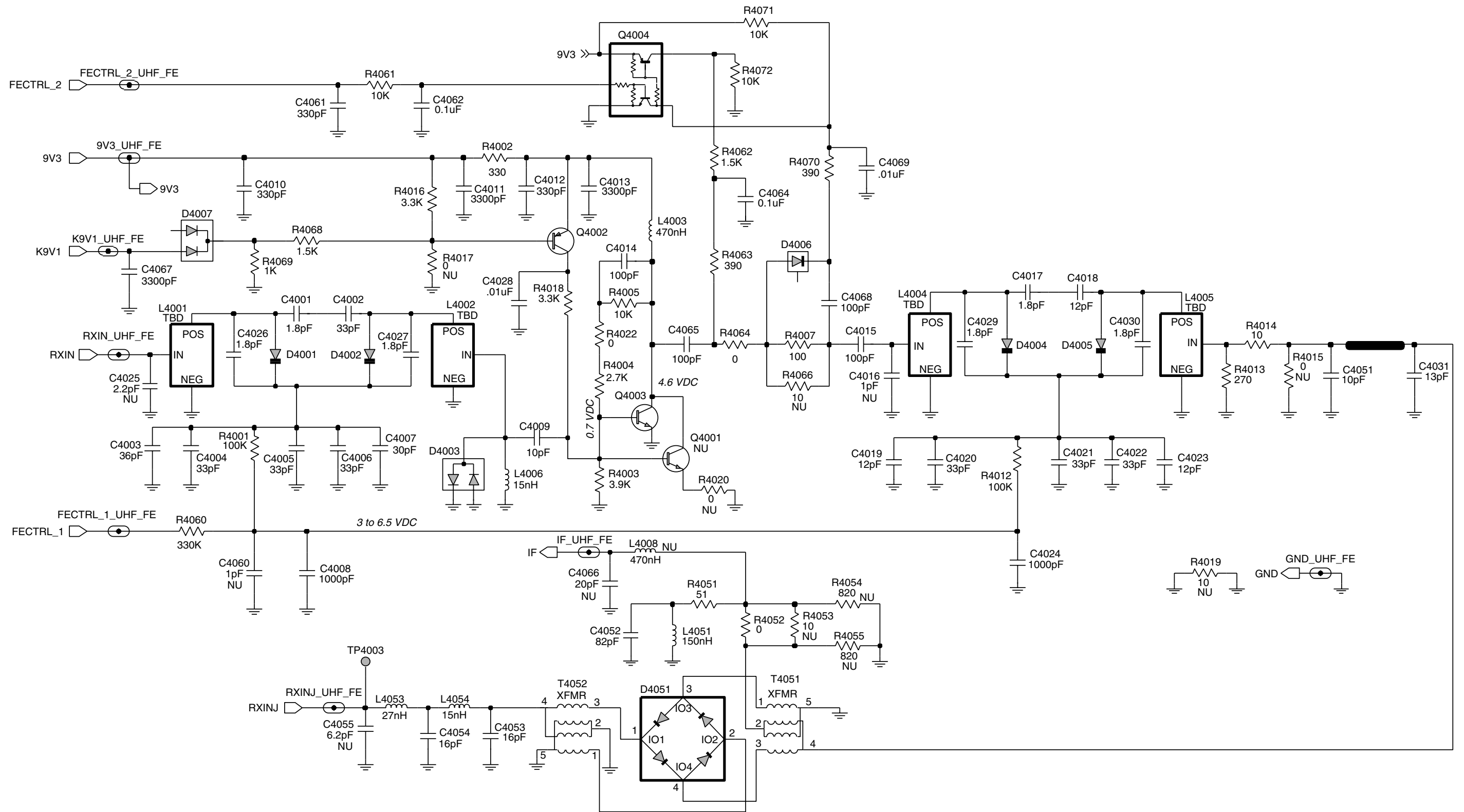

ZWG0130625-O

UHF (403-470 MHz) Receiver Front End

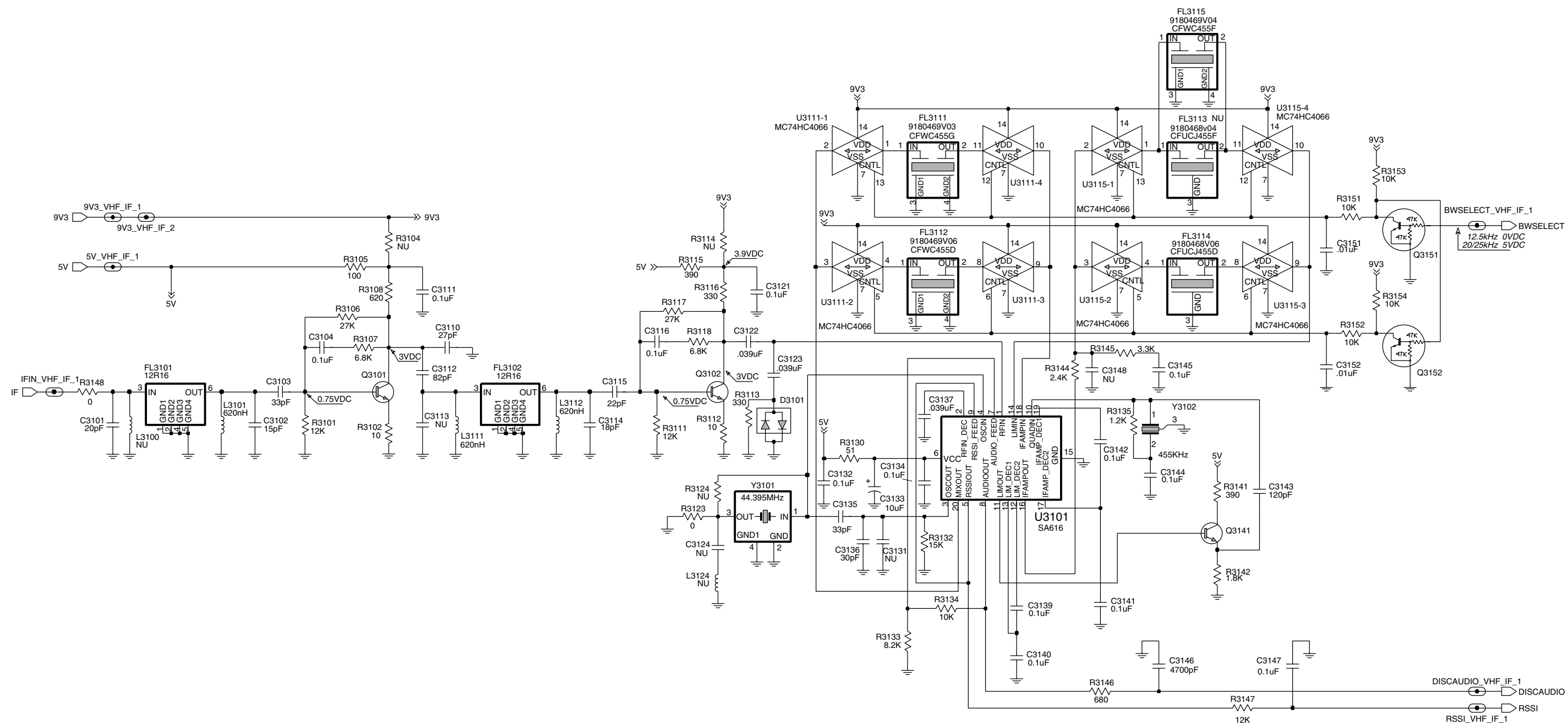

ZWG0130623-O

UHF (403-470 MHz) IF

4.1 UHF PCB 8485670z03 Parts List 1-25W

Circuit Ref	Motorola Part No.	Description
C3101	2113740F34	20pF
C3102	2113740F31	15pF
C3103	2113740F39	33pF
C3104	2113743E20	100nF
C3110	2113740F37	27pF
C3111	2113743E20	100nF
C3112	2113740F49	82pF
C3114	2113740F33	18pF
C3115	2113740F35	22pF
C3116	2113743E20	100nF
C3121	2113743E20	100nF
C3122	2113743E11	0.039uF
C3123	2113743E11	0.039uF
C3132	2113743E20	100nF
C3133	2311049A57	10uF
C3134	2113743E20	100nF
C3135	2113740L30	33pF
C3136	2113740L29	30pF
C3137	2113743E11	0.039uF
C3139	2113743E20	100nF
C3140	2113743E20	100nF
C3141	2113743E20	100nF
C3142	2113743E20	100nF
C3143	2113740F53	120pF
C3144	2113743E20	100nF
C3145	2113743E20	100nF
C3146	2113741F41	4700pF
C3147	2113743E20	100nF
C3151	2113741F49	10nF
C3152	2113741F49	10nF
C4001	2113740F09	1.8pF
C4002	2113740F39	33pF
C4003	2113740F40	36pF
C4004	2113740F39	33pF
C4005	2113740F39	33pF
C4006	2113740F39	33pF
C4007	2113740F38	30pF
C4008	2113741F25	1000pF
C4009	2113740F27	10pF
C4010	2113741F13	330pF
C4011	2113741F37	3300pF
C4012	2113741F13	330pF
C4013	2113741F37	3300pF
C4014	2113740F51	100pF
C4015	2113740F51	100pF
C4017	2113740F09	1.8pF
C4018	2113740F29	12pF
C4019	2113740F29	12pF
C4020	2113740F39	33pF
C4021	2113740F39	33pF
C4022	2113740F39	33pF
C4023	2113740F29	12pF
C4024	2113741F25	1000pF
C4026	2113740F09	1.8pF

Circuit Ref	Motorola Part No.	Description
C4027	2113740F09	1.8pF
C4028	2113741F49	10nF
C4029	2113740F09	1.8pF
C4030	2113740F09	1.8pF
C4031	2113740F30	13pF
C4051	2113740F27	10pF
C4052	2113740F49	82pF
C4053	2113740F32	16pF
C4054	2113740F32	16pF
C4061	2113740F63	330pF
C4062	2113743E20	100nF
C4064	2113743E20	100nF
C4065	2113740F51	100pF
C4067	2113741F37	3300pF
C4068	2113740F51	100pF
C4069	2113741F49	10nF
C4201	2113740F51	100pF
C4202	2113741F49	10nF
C4203	2113741F49	10nF
C4204	2113740F51	100pF
C4205	2113741F49	10nF
C4206	2311049J25	10uF
C4208	2113743E20	100nF
C4209	2113743E20	100nF
C4210	2104993J02	2.2uF
C4211	2113743E20	100nF
C4213	2311049A09	2.2uF
C4214	2311049A09	2.2uF
C4215	2311049A09	2.2uF
C4217	2113741F49	10nF
C4221	2109720D01	0.01uF
C4222	2109720D14	0.1uF
C4224	0882422W23	1uF
C4225	2113741F18	510pF
C4226	2113740L03	2.4pF
C4227	2113740F27	10pF
C4230	2104993J02	2.2uF
C4231	2113741F49	10nF
C4232	2113741F49	10nF
C4233	2104993J02	2.2uF
C4234	2113741F49	10nF
C4235	2113741F49	10nF
C4236	2113743E12	0.047uF
C4242	2113740F51	100pF
C4243	2113740F51	100pF
C4244	2113740F51	100pF
C4245	2113740F51	100pF
C4246	2113740F51	100pF
C4251	2113743E20	100nF
C4252	2113741F25	1000pF
C4253	2311049A56	4.7uF
C4254	2113743E20	100nF
C4255	2113740F51	100pF
C4263	2113743E20	100nF
C4287	2113740F51	100pF
C4289	2113743E20	100nF

Circuit Ref	Motorola Part No.	Description
C4301	2113740F51	100pF
C4302	2113740L16	8.2pF
C4303	2113740L16	8.2pF
C4304	2113740L08	3.9pF
C4306	2113740L01	2pF
C4307	2113740F51	100pF
C4308	2113743E20	100nF
C4309	2113740F51	100pF
C4311	2113740F51	100pF
C4312	2113740F29	12pF
C4314	2113740F07	1.5pF
C4315	2113740F51	100pF
C4316	2109720D14	0.1uF
C4318	2113743E20	100nF
C4321	2113740F03	1pF
C4324	2113740L03	2.4pF
C4325	2311049A56	4.7uF
C4331	2113740L14	6.8pF
C4335	2113740F51	100pF
C4336	2113743E07	0.022uF
C4337	2113740F44	51pF
C4338	2113740F44	51pF
C4351	2113740F51	100pF
C4352	2113743E20	100nF
C4353	2113743E20	100nF
C4354	2104993J02	2.2uF
C4355	2104993J02	2.2uF
C4361	2113741F25	1000pF
C4364	2113740F21	5.6pF
C4365	2113740F07	1.5pF
C4371	2113743E20	100nF
C4400	2113740F67	470pF
C4401	2113740F51	100pF
C4402	2113741F37	3300pF
C4403	2113740F23	6.8pF
C4404	2113740F51	100pF
C4405	2113740F51	100pF
C4406	2113740F51	100pF
C4407	2113740F51	100pF
C4408	2113740F51	100pF
C4411	2113741F37	3300pF
C4412	2113740F51	100pF
C4414	2113740F51	100pF
C4415	2113743E07	0.022uF
C4416	2113740F51	100pF
C4417	2113740F38	30pF
C4419	2113740F33	18pF
C4420	2113740F28	11pF
C4421	2113741A57	33K F
C4422	2113740A55	100pF
C4423	2311049A08	1uF
C4425	2113741F49	10nF
C4426	2113740F51	100pF
C4427	2113741F37	3300pF
C4428	2113741F33	2200pF
C4431	2111078B23	24pF

Circuit Ref	Motorola Part No.	Description
C4434	2113741F49	10nF
C4435	2113740A55	100pF
C4436	2311049A45	10uF
C4437	2113741A57	33K F
C4439	2111078B42	100pF
C4440	2113741F25	1000pF
C4441	2111078B18	15pF
C4446	2111078B09	6.8pF
C4448	2111078B29	33pF
C4449	2111078B29	33pF
C4451	2113741F25	1000pF
C4452	2113740F30	13pF
C4453	2113740F51	100pF
C4455	2111078B12	9.1pF
C4457	2111078B27	30pF
C4458	2111078B32	39pF
C4459	2113740F51	100pF
C4471	2113740F51	100pF
C4472	2111078B31	36pF
C4473	2111078B31	36pF
C4474	2113740F51	100pF
C4475	2113740F21	5.6pF
C4491	2111078B12	9.1pF
C4492	2111078B32	39pF
C4496	2111078B09	6.8pF
C4497	2111078B07	5.6pF
C4501	2113741F33	2200pF
C4502	2113741F33	2200pF
C4503	2113740F67	470pF
C4504	2113741F49	10nF
C4505	2311049A07	1uF
C4506	2113741F33	2200pF
C4507	2113740F51	100pF
C4508	2113740F51	100pF
C4510	2113740F51	100pF
CR4301	4805649Q13	DIODE, VARACTOR
CR4302	4862824C01	DIODE, VARACTOR
CR4303	4862824C01	DIODE, VARACTOR
CR4311	4802245J22	DIODE, VARACTOR
CR4321	4862824C01	DIODE, VARACTOR
D3101	4880154K03	DIODE DUAL SCHOTTKY
D4001	4862824C01	DIODE, VARACTOR
D4002	4862824C01	DIODE, VARACTOR
D4003	4880154K03	DIODE DUAL SCHOTTKY
D4004	4862824C01	DIODE, VARACTOR
D4005	4862824C01	DIODE, VARACTOR
D4006	4880142L01	DIODE
D4007	4813833C02	DIODE, DUAL 70V
D4051	4886143B01	DIODE, MIXER
D4201	4802233J09	DIODE, TRIPLE
D4221	4813825A05	DIODE
D4401	4813833C02	DIODE, DUAL 70V
D4451	4813825A05	DIODE
D4471	4802482J02	DIODE
D4472	4802482J02	DIODE
FL3101	9180112R16	2 POLE 44.85 MHZ XSTAL FILTER

Circuit Ref	Motorola Part No.	Description
FL3102	9180112R16	2 POLE 44.85 MHZ XSTAL FILTER
FL3111	9180469V03	6 ELEMENT CER FILTER, 455KHZ
FL3112	9180469V06	6 ELEMENT CER FILTER, 455KHZ
FL3114	9180468V06	4 ELEMENT CER FILTER, 455KHZ
FL3115	9180469V04	6 ELEMENT CER FILTER, 455KHZ
J4401	0986166B01	MOBILE RF CONNECTOR (BNC)
L3101	2462587T25	620nH
L3111	2462587T25	620nH
L3112	2462587T25	620nH
L4003	2462587T23	470nH
L4006	2462587V24	15nH
L4008	2462587T23	470nH
L4051	2462587T17	150nH
L4053	2462587N46	27nH
L4054	2462587N43	15nH
L4201	2462587Q42	390nH
L4221	2462587P25	12000nH
L4231	2462587Q20	2200nH
L4301	2462587T22	390nH
L4302	2462587T22	390nH
L4303	2460593C01	RESONATOR
L4304	2462587T22	390nH
L4305	2462587T22	390nH
L4311	2462587T22	390nH
L4312	2460593C01	RESONATOR
L4313	2462587T22	390nH
L4331	2462587T09	33nH
L4333	2462587T22	390nH
L4361	2462587T09	33nH
L4362	2462587T09	33nH
L4371	2462587T13	68nH
L4401	2460591B04	11.03nH
L4402	2484657R01	Ferrite Bead
L4403	2462587N50	56nH
L4411	2462587N44	18nH
L4421	2484657R01	Ferrite Bead
L4422	2460591A01	4.22nH
L4436	2484657R01	Ferrite Bead
L4437	2460592A01	17nH
L4471	2462587T22	390nH
L4472	2460592A01	17nH
L4491	2460592A01	17nH
L4493	2460592A01	17nH
M3421	2686201B01	HEAT SPREADER
Q3101	4813827A07	NPN
Q3102	4813827A07	NPN
Q3141	4880214G02	NPN
Q3151	4880048M01	NPN
Q3152	4880048M01	NPN
Q4002	4813824A17	PNP
Q4003	4813827A07	NPN
Q4004	4805921T02	DUAL DIGITAL NPN/PNP
Q4221	4880048M01	NPN
Q4301	4805218N63	DIODE DUAL SCHOTTKY
Q4332	4813827A07	NPN
Q4333	4802245J50	TRANSISTOR DUAL NPN/PNP

Circuit Ref	Motorola Part No.	Description
Q4411	4805921T02	DUAL DIGITAL NPN/PNP
Q4421	4886212B01	RF Power LDMOS MRF1518
Q4422	4880048M01	NPN
Q4441	4886136B01	RF Power LDMOS MRF1535
Q4442	4880048M01	NPN
Q4471	4880048M01	NPN
Q4472	4805128M27	PNP
R3101	0662057A75	12K Ohm
R3102	0662057A01	10 Ohm
R3105	0662057A25	100 Ohm
R3106	0662057A83	27K Ohm
R3107	0662057A69	6800 Ohm
R3108	0662057A44	620 Ohm
R3111	0662057A75	12K Ohm
R3112	0662057A01	10 Ohm
R3113	0662057A37	330 Ohm
R3115	0662057A39	390 Ohm
R3116	0662057A37	330 Ohm
R3117	0662057A83	27K Ohm
R3118	0662057A69	6800 Ohm
R3123	0662057B47	0 Ohm
R3130	0662057A18	51 Ohm
R3132	0662057A77	15K Ohm
R3133	0662057A71	8200 Ohm
R3134	0662057A73	10K Ohm
R3135	0662057A51	1200 Ohm
R3141	0662057A39	390 Ohm
R3142	0662057A55	1800 Ohm
R3144	0662057A58	2400 Ohm
R3145	0662057A61	3300 Ohm
R3146	0662057A45	680 Ohm
R3147	0662057A75	12K Ohm
R3148	0662057B47	0 Ohm
R3151	0662057A73	10K Ohm
R3152	0662057A73	10K Ohm
R3153	0662057A73	10K Ohm
R3154	0662057A73	10K Ohm
R4001	0662057A97	100K Ohm
R4002	0662057A37	330 Ohm
R4003	0662057A63	3900 Ohm
R4004	0662057A59	2700 Ohm
R4005	0662057A73	10K Ohm
R4007	0662057A25	100 Ohm
R4012	0662057A97	100K Ohm
R4013	0662057A35	270 Ohm
R4014	0662057A01	10 Ohm
R4016	0662057A61	3300 Ohm
R4018	0662057A61	3300 Ohm
R4022	0662057B47	0 Ohm
R4051	0662057A18	51 Ohm
R4052	0662057B47	0 Ohm
R4060	0662057B10	330K Ohm
R4061	0662057A73	10K Ohm
R4062	0662057A53	1500 Ohm
R4063	0662057A39	390 Ohm
R4064	0662057B47	0 Ohm

Circuit Ref	Motorola Part No.	Description
R4068	0662057A53	1500 Ohm
R4069	0662057A49	1000 Ohm
R4070	0662057A39	390 Ohm
R4071	0662057A73	10K Ohm
R4072	0662057A73	10K Ohm
R4201	0662057A29	150 Ohm
R4203	0662057A17	47 Ohm
R4204	0662057A17	47 Ohm
R4211	0662057B47	0 Ohm
R4221	0662057A29	150 Ohm
R4222	0662057A42	510 Ohm
R4223	0662057A21	68 Ohm
R4224	0662057A89	47K Ohm
R4225	0662057A89	47K Ohm
R4228	0662057A73	10K Ohm
R4241	0662057A33	220 Ohm
R4251	0662057A87	39K Ohm
R4252	0662057A84	30K Ohm
R4261	0662057A89	47K Ohm
R4263	0662057A25	100 Ohm
R4301	0662057A67	5600 Ohm
R4302	0662057A73	10K Ohm
R4303	0662057A12	30 Ohm
R4304	0662057A31	180 Ohm
R4305	0662057A01	10 Ohm
R4311	0662057A70	7500 Ohm
R4312	0662057A67	5600 Ohm
R4313	0662057A12	30 Ohm
R4314	0662057A35	270 Ohm
R4315	0662057B47	0 Ohm
R4321	0662057A91	56K Ohm
R4322	0662057A73	10K Ohm
R4323	0662057A97	100K Ohm
R4331	0662057A09	22 Ohm
R4341	0662057B47	0 Ohm
R4342	0662057A57	2200 Ohm
R4343	0662057A49	1000 Ohm
R4344	0662057A01	10 Ohm
R4346	0662057A73	10K Ohm
R4347	0662057B47	0 Ohm
R4360	0662057A35	270 Ohm
R4361	0662057A31	180 Ohm
R4362	0662057A01	10 Ohm
R4363	0662057A49	1000 Ohm
R4381	0662057A41	470 Ohm
R4400	0662057A43	560 Ohm
R4401	0662057A36	300 Ohm
R4402	0662057A05	15 Ohm
R4403	0662057A36	300 Ohm
R4404	0662057A89	47K Ohm
R4406	0662057A97	100K Ohm
R4412	0662057A69	6800 Ohm
R4413	0662057A61	3300 Ohm
R4415	0662057A18	51 Ohm
R4416	0662057A18	51 Ohm
R4418	0662057A59	2700 Ohm

Circuit Ref	Motorola Part No.	Description
R4421	0662057A87	39K Ohm
R4422	0662057A57	2200 Ohm
R4423	0662057A87	39K Ohm
R4424	0662057C13	2.7 Ohm
R4425	0662057C13	2.7 Ohm
R4426	0662057C13	2.7 Ohm
R4427	0662057C13	2.7 Ohm
R4428	0662057A58	2400 Ohm
R4429	0662057A59	2700 Ohm
R4431	0680194M18	51 Ohm
R4441	0662057A87	39K Ohm
R4442	0662057A57	2200 Ohm
R4443	0662057A87	39K Ohm
R4445	0662057A58	2400 Ohm
R4446	0662057B47	0 Ohm
R4452	0662057A75	12K Ohm
R4454	0662057A73	10K Ohm
R4455	0662057A97	100K Ohm
R4457	0683962T51	120 Ohm
R4458	0662057A41	470 Ohm
R4471	0662057A41	470 Ohm
R4473	0680194M18	51 Ohm
R4474	0680194M18	51 Ohm
R4475	0662057A73	10K Ohm
R4491	0662057A73	10K Ohm
R4501	0662057A69	6800 Ohm
R4502	0662057A83	27K Ohm
R4504	0662057A73	10K Ohm
R4505	0662057B09	300K Ohm
R4507	0662057A80	20K Ohm
R4508	0662057A97	100K Ohm
R4509	0662057A49	1000 Ohm
R4511	0662057C19	4.7 Ohm
SH4301	2602641Y02	SHIELD
SH4302	2602641Y02	SHIELD
T4051	2505515V03	XFMR MIXER 4:1
T4052	2505515V04	XMFR MIXER 5:1
U3101	5186144B01	IC, IF
U3111	5102463J52	QUAD ANALOG SWITCH
U3115	5102463J52	QUAD ANALOG SWITCH
U4201	5185963A27	IC FRACTN
U4211	5105739X05	IC, VOLTAGE REGULATOR
U4301	5105750U54	IC, VCO
U4401	5185130C65	IC LDMOS DRIVER
U4402	5113818A01	LOW POWER SUPPLY
U4501	5185765B28	IC POWER CONTROL
U4502	5185963A15	IC TEMPERATURE SENSOR
VR4471	4813830A15	DIODE, 5.6V
Y3101	4880606B09	2ND OSC XTAL 44.395 MHZ
Y3102	9186145B02	455KHZ DISCRIMINATOR
Y4262	4886182B01	TCXO 16.8MHZ



Professional Radio

GM Series

VHF (136-174MHz)

Service Information

Computer Software Copyrights

The Motorola products described in this manual may include copyrighted Motorola computer programs stored in semiconductor memories or other media. Laws in the United States and other countries preserve for Motorola certain exclusive rights for copyrighted computer programs, including the exclusive right to copy or reproduce in any form, the copyrighted computer program. Accordingly, any copyrighted Motorola computer programs contained in the Motorola products described in this manual may not be copied or reproduced in any manner without the express written permission of Motorola. Furthermore, the purchase of Motorola products shall not be deemed to grant, either directly or by implication, estoppel or otherwise, any license under the copyrights, patents or patent applications of Motorola, except for the normal non-exclusive royalty-free license to use that arises by operation of law in the sale of a product.

Table of Contents

Chapter 1 MODEL CHART AND TECHNICAL SPECIFICATIONS

1.0 GM140/GM160 Model Chart.....	1-1
2.0 GM340/GM360/GM380 Model Chart.....	1-1
3.0 GM640/GM660/GM1280 Model Chart.....	1-2
4.0 Technical Specifications	1-3

Chapter 2 THEORY OF OPERATION

1.0 Introduction	2-1
2.0 VHF (136-174MHz) Receiver.....	2-1
2.1 Receiver Front-End	2-1
2.1 Front-End Band-Pass Filters & Pre-Amplifier	2-2
2.2 First Mixer and High Intermediate Frequency (IF)	2-2
2.3 Low Intermediate Frequency (IF) and Receiver Back End	2-2
3.0 VHF (136-174MHz) Transmitter Power Amplifier (PA) 25 W.....	2-3
3.1 First Power Controlled Stage.....	2-3
3.2 Power Controlled Driver Stage	2-4
3.3 Final Stage	2-4
3.4 Directional Coupler.....	2-4
3.5 Antenna Switch.....	2-5
3.6 Harmonic Filter	2-5
3.7 Power Control	2-5
4.0 VHF (136-174MHz) Frequency Synthesis	2-6
4.1 Reference Oscillator	2-6
4.2 Fractional-N Synthesizer	2-6
4.3 Voltage Controlled Oscillator (VCO)	2-7
4.4 Synthesizer Operation	2-8
5.0 VHF (136-174MHz) Transmitter Power Amplifier (PA) 45 W.....	2-9
5.1 Power Controlled Stage.....	2-9
5.2 Pre-Driver Stage.....	2-10
5.3 Driver Stage.....	2-10
5.4 Final Stage	2-10
5.5 Directional Coupler.....	2-10
5.6 Antenna Switch.....	2-11
5.7 Harmonic Filter	2-11
5.8 Power Control.....	2-11

Chapter 3 TROUBLESHOOTING CHARTS

1.0	Troubleshooting Flow Chart for Receiver (Sheet 1 of 2)	3-1
1.1	Troubleshooting Flow Chart for Receiver (Sheet 2 of 2)	3-2
2.0	Troubleshooting Flow Chart for 25W Transmitter (Sheet 1 of 3)	3-3
2.1	Troubleshooting Flow Chart for 25W Transmitter (Sheet 2 of 3)	3-4
2.2	Troubleshooting Flow Chart for 25W Transmitter (Sheet 3 of 3)	3-3
3.0	Troubleshooting Flow Chart for 45W Transmitter (Sheet 1 of 2)	3-4
3.1	Troubleshooting Flow Chart for 45W Transmitter (Sheet 2 of 2)	3-4
4.0	Troubleshooting Flow Chart for Synthesizer	3-5
5.0	Troubleshooting Flow Chart for VCO	3-6

Chapter 4 VHF PCB/SCHEMATICS/PARTS LISTS

1.0	Allocation of Schematics and Circuit Boards	4-1
1.1	Controller Circuits	4-1
2.0	VHF 1-25W PCB 8486172B04 / Schematics	4-3
2.1	VHF 1-25W PCB 8486172B04 Parts List	4-10
3.0	VHF 1-25W PCB 8486172B06 / Schematics	4-13
3.1	VHF 1-25W PCB 8486172B06 Parts List	4-20
4.0	VHF 1-25W PCB 8486172B07 / Schematics	4-23
4.1	VHF 1-25W PCB 8486172B07 Parts List	4-27
5.0	VHF 1-25W PCB 8486172B08 / Schematics	4-31
5.1	VHF 1-25W PCB 8486172B08 Parts List	4-38
6.0	VHF 25-45W PCB 8486140B12 / Schematics	4-41
6.1	VHF 25-45W PCB 8486140B12 Parts List	4-44
7.0	VHF 25-45W PCB 8486140B13 / Schematics	4-47
7.1	VHF 25-45W PCB 8486140B13 Parts List	4-49

Chapter 1

MODEL CHART AND TECHNICAL SPECIFICATIONS

1.0 GM140/GM160 Model Chart

GM Series VHF 136-174 MHz			
Model		Description	
MDM25KKC9AA1_E		GM140, 136-174 MHz, 25-45W, 4 Ch	
MDM25KKF9AA5_E		GM160, 136-174 MHz, 25-45W, 128 Ch	
		Item	Description
X		GCN6112_	Control Head, GM140
	X	GCN6114_	Control Head, GM160
X		IMUD6015_S	Field Replaceable Unit (Main Board) GM140
	X	IMUD6015_S	Field Replaceable Unit (Main Board) GM160
X	X	ENBN4056_	Packaging, Waris Mobile Radio
X	X	GLN7324_	Low Profile Mounting Trunnion
X	X	HKN9402_	12V Power Cable, 25-45W
X	X	MDRMN4025_	Enhanced Compact Microphone
X		6864110B86	User Guide, GM140
	X	6864110B87	User Guide, GM160
X = Indicates one of each is required			

2.0 GM340/GM360/GM380 Model Chart

GM Series VHF 136-174 MHz					
Model				Description	
MDM25KHC9AN1_E				GM340, 136-174 MHz, 1-25W, 6 Ch	
MDM25KHF9AN5_E				GM360, 136-174 MHz, 1-25W, 255 Ch	
MDM25KHC9AN8_E				GM380, 136-174 MHz, 1-25W, 255 Ch	
MDM25KHA9AN0_E				Databox, 136-174 MHz, 1-25W, 16 Ch	
Item				Description	
X				GCN6112_	Control Head GM340
	X			GCN6120_	Control Head GM360
		X		GCN6121_	Control Head GM380
			X	GCN6116_	Databox Radio Blank Head
X				IMUD6013_S	Field Replaceable Unit (Main Board) GM340
	X			IMUD6013_S	Field Replaceable Unit (Main Board) GM360
		X		IMUD6024_S	Field Replaceable Unit (Main Board) GM380
			X	IMUD6015_A	S/T 136-174 MHz 1-25 SEL5
X	X	X	X	ENBN4056_	Packaging, Waris Mobile
X	X	X	X	GLN7324_	Low Profile Mounting Trunnion
X	X	X	X	HKN4137_	12V Power Cable 1-25W
X	X	X		MDRMN4025_	Enhanced Compact Microphone
X				6864110B80	User Guide GM340
	X			6864110B81	User Guide, GM360
		X		6864110B82	User Guide, GM380

X = Indicates one of each is required

3.0 GM640/GM660/GM1280 Model Chart

GM Series VHF 136-174 MHz				
Model				Description
			MDM25KHC9CK1_E	GM640, 136-174 MHz, 1-25W, 6 Ch
			MDM25KHF9CK5_E	GM660, 136-174 MHz, 1-25W, 255 Ch
			MDM25KHN9CK8_E	GM1280, 136-174 MHz, 1-25W, 255 Ch
			MDM25KHA9CK7_E	Databox, 136-174 MHz, 1-25W, 16 Ch
			Item	Description
X			GCN6112_	Control Head GM640
	X		GCN6120_	Control Head GM660
		X	GCN6121_	Control Head GM1280
			X GCN6116_	Databox Radio Blank Head
X			IMUD6018_S	Field Replaceable Unit (Main Board) GM640
	X		IMUD6018_S	Field Replaceable Unit (Main Board) GM660
		X	IMUD6018_S	Field Replaceable Unit (Main Board) GM1280
			X IMUD6018_S	S/T 136-174 MHz 1-25 SEL5
X	X	X	X ENBN4056_	Packaging, Waris Mobile Radio
X	X	X	X GLN7324_	Low Profile Mounting Trunnion
X	X	X	X HKN4137_	12V Power Cable, 1-25W
X	X	X	MDRMN4025_	Enhanced Compact Microphone
X			6864110B83_	User Guide, GM640
	X		6864110B84_	User Guide, GM660
		X	6864110B85_	User Guide, GM1280

X = Indicates one of each is required

4.0 Technical Specifications

Data is specified for +25°C unless otherwise stated.

General Specifications	
Channel Capacity	
GM140	4
GM160	128
GM340	6
GM360	255
GM380	255
GM640	6
GM660	255
GM1280	255
Databox	16
Power Supply	13.2Vdc (10.8 - 15.6Vdc)
Dimensions: H x W x D (mm) Depth excluding knobs	GM140/340/640 56mm x 176mm x 177mm (1 - 25W) 56mm x 176mm x 189mm (25 - 45W) (add 8mm for Volume Knob)
Dimensions: H x W x D (mm) Depth excluding knobs	GM160/360/660 59mm x 179mm x 186mm (1 - 25W) 59mm x 179mm x 198mm (25 - 45W) (add 9mm for Volume Knob)
Dimensions: H x W x D (mm) Depth excluding knobs	GM380/1280 188mm x 185mm x 72mm (add 8mm for Volume Knob)
Dimensions: H x W x D (mm) Depth excluding knobs	Databox 44mm x 168mm x 161mm
Weight GM140/340/640	1400gr
Weight GM160/360/660	1400gr
Weight GM380/1280	1500gr
Weight Databox	1220gr
Sealing:	Withstands rain testing per MIL STD 810 C/D /E and IP54
Shock and Vibration:	Protection provided via impact resistant housing exceeding MIL STD 810-C/D /E and TIA/EIA 603
Dust and Humidity:	Protection provided via environment resistant housing exceeding MIL STD 810 C/D /E and TIA/EIA 603

Transmitter	VHF
*Frequencies - Full Bandsplit	VHF 136-174 MHz
Channel Spacing	12.5/20/25 kHz
Frequency Stability (-30°C to +60°C, +25° Ref.)	±2.5 ppm
Power	1-25W / 25-45W
Modulation Limiting	±2.5 @ 12.5 kHz ±4.0 @ 20 kHz ±5.0 @ 25 kHz
FM Hum & Noise	-40 dB @ 12.5kHz -45 dB @ 20/25kHz
Conducted/Radiated Emission (ETS)	-36 dBm <1 GHz -30 dBm >1 GHz
Adjacent Channel Power	-60 dB @ 12.5 kHz -70 dB @ 25 kHz
Audio Response (300 - 3000Hz)	+1 to -3 dB
Audio Distortion @1000Hz, 60% Rated Maximum Deviation	<3% typical

Receiver	VHF
*Frequencies - Full Bandsplit	VHF 136-174 MHz
Channel Spacing	12.5/20/25 kHz
Sensitivity (12 dB SINAD)	0.30 µV (0.22 µV typical)
Intermodulation (ETS)	>65 dB Base Mode: >70dB (1-25W model only)
Adjacent Channel Selectivity (ETS)	65 dB @ 12.5 kHz 75 dB @ 20 kHz 80 dB @ 25 kHz
Spurious Rejection (ETS)	75 dB @ 12.5 kHz 80 dB @ 20/25 kHz
Rated Audio	3W Internal 13W External
Audio Distortion @ Rated Audio	<3% typical
Hum & Noise	-40 dB @ 12.5 kHz -45 dB @ 20/25 kHz
Audio Response (300 - 3000Hz @ 20/25kHz) (300 - 2550Hz @ 12.5kHz)	+1 to -3 dB
Conducted Spurious Emission (ETS)	-57 dBm <1 GHz -47 dBm >1 GHz

*Availability subject to the laws and regulations of individual countries.

THEORY OF OPERATION

1.0 Introduction

This Chapter provides a detailed theory of operation for the VHF circuits in the radio. For details of the theory of operation and trouble shooting for the the associated Controller circuits refer to the Controller Section of this manual.

2.0 VHF (136-174MHz) Receiver

2.1 Receiver Front-End

The receiver is able to cover the VHF range from 136 to 174 MHz. It consists of four major blocks: front-end bandpass filters and pre-amplifier, first mixer, high-IF, low-IF and receiver back-end. Two varactor-tuned bandpass filters perform antenna signal pre-selection. A cross over quad diode mixer converts the signal to the first IF of 44.85 MHz. High-side first injection is used.

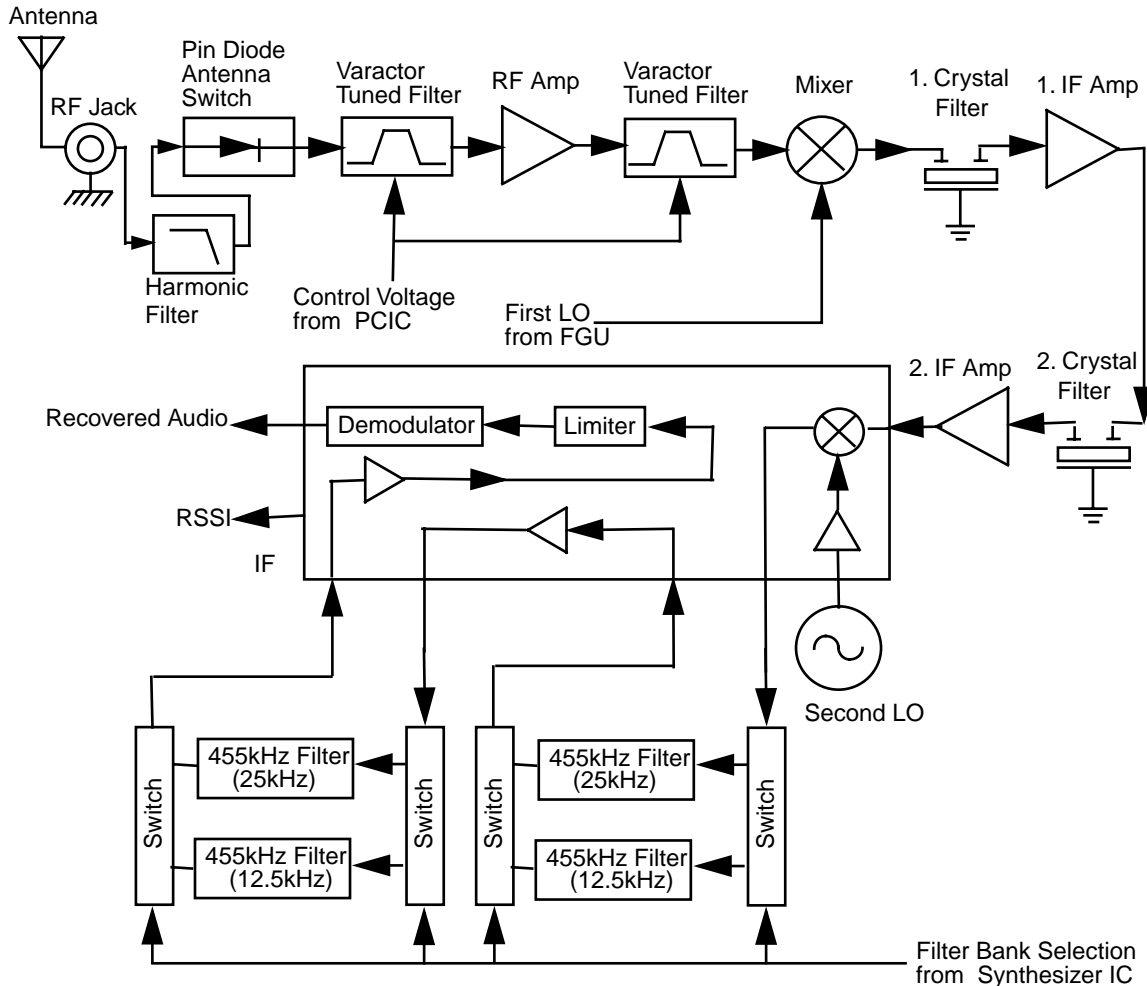

Figure 2-1 VHF Receiver Block Diagram

There are two 2-pole 44.85 MHz crystal filters in the high-IF section and 2 pairs of 455 kHz ceramic filters in the low-IF section to provide the required adjacent channel selectivity. The correct pair of ceramic filters for 12.5 or 25kHz channel spacing is selected via control line BWSELECT. The second IF at 455 kHz is mixed, amplified and demodulated in the IF IC. The processing of the demodulated audio signal is performed by an audio processing IC located in the controller section.

2.2 Front-End Band-Pass Filters & Pre-Amplifier

The received signal from the radio's antenna connector is first routed through the harmonic filter and antenna switch, which are part of the RF power amplifier circuitry, before being applied to the receiver pre-selector filter (C3001, C3002, D3001 and associated components). The 2-pole pre-selector filter tuned by the dual varactor diode D3001 pre-selects the incoming signal (RXIN) from the antenna switch to reduce spurious effects to following stages. The tuning voltage (FECNTL_1) ranging from 2 volts to 8 volts is controlled by pin 20 of PCIC (U3501) in the Transmitter section. A dual hot carrier diode (D3003) limits any inband signal to 0 dBm to prevent damage to the pre-amplifier.

The RF pre-amplifier is an SMD device (Q3001) with collector-base feedback to stabilize gain, impedance, and intermodulation. Transistor Q3002 compares the voltage drop across resistor R3002 with a fixed base voltage from divider R3011, R3000 and R3012, and adjusts the base current of Q3001 as necessary to maintain its collector current constant at approximately 15-20 mA. Operating voltage is from the regulated 9.3V supply (9V3). During transmit, 9.1 volts (K9V1) turns off both transistors Q3002 and Q3001. This protects the RF pre-amplifier from excessive dissipation during transmit mode. A switchable 3dB pad (R3022, R3024, R3016 and R3018) controlled via Line FECNTL_2 and Q3021 stabilizes the output impedance and intermodulation performance.

A second 2-pole varactor tuned bandpass filter provides additional filtering of the amplified signal. The dual varactor diode D3004 is controlled by the same signal FECNTL_1, which controls the pre-selector filter.

2.3 First Mixer and High Intermediate Frequency (IF)

The signal coming from the front-end is converted to the high-IF frequency of 44.85 MHz using a cross over quad diode mixer (D3031). Its ports are matched for incoming RF signal conversion to the 44.85 MHz IF using high side injection. The high-side injection signal (RXINJ) from the frequency synthesizer circuitry has a level of approximately 13 dBm and is injected via matching transformer T3002.

The mixer IF output signal (IF) from transformer T3001 pin 2 is fed to the first two pole crystal filter FL3101. The filter output in turn is matched to the following IF amplifier.

The IF amplifier Q3101 is actively biased by a collector base feedback (R3101, R3106) to a current drain of approximately 5 mA drawn from the voltage 5V. Its output impedance is matched to the second two pole crystal filter FL3102. The signal is further amplified by a preamplifier (Q3102) before going into pin 1 of IFIC (U3101).

A dual hot carrier diode (D3101) limits the filter output voltage swing to reduce overdrive effects at RF input levels above -27 dBm.

2.4 Low Intermediate Frequency (IF) and Receiver Back End

The 44.85 MHz high-IF signal from the second IF amplifier feeds the IF IC (U3101) at pin1. Within the IF IC, the 44.85 MHz high IF signal mixes with the 44.395 MHz second local oscillator (2nd LO) to produce the low-IF signal at 455 kHz. The 2nd LO frequency is determined by crystal Y3101. The

low IF signal is amplified and filtered by an external pair of 455 kHz ceramic filters FL3112, FL3114 for 20/25 kHz channel spacing or FL3111, FL3113/F3115 for 12.5 kHz channel spacing. These pairs are selectable via BWSELECT. The filtered output from the ceramic filters is applied to the limiter input pin of the IF IC (pin 14).

The IF IC contains a quadrature detector using a ceramic phase-shift element (Y3102) to provide audio detection. Internal amplification provides an audio output level of 120 mV rms (at 60% deviation) from U3101 pin 8 (DISCAUDIO) which is fed to the ASFIC_CMP (U0221) pin 2 (part of the Controller circuitry).

A received signal strength indicator (RSSI) signal is available at U3101 pin 5, having a dynamic range of 70 dB. The RSSI signal is interpreted by the microprocessor (U0101 pin 63) and in addition is available at accessory connector J0501-15.

3.0 VHF (136-174MHz) Transmitter Power Amplifier (PA) 25 W

The radio's 25 W PA is a three stage amplifier used to amplify the output from the VCOBIC to the radio transmit level. All three stages utilize LDMOS technology. The gain of the first stage (U3401) and the second stage (Q3421) is adjustable, controlled by pin 4 of PCIC (U3501) via U3402-1 and U3402-2. It is followed by an LDMOS final stage (Q3441).

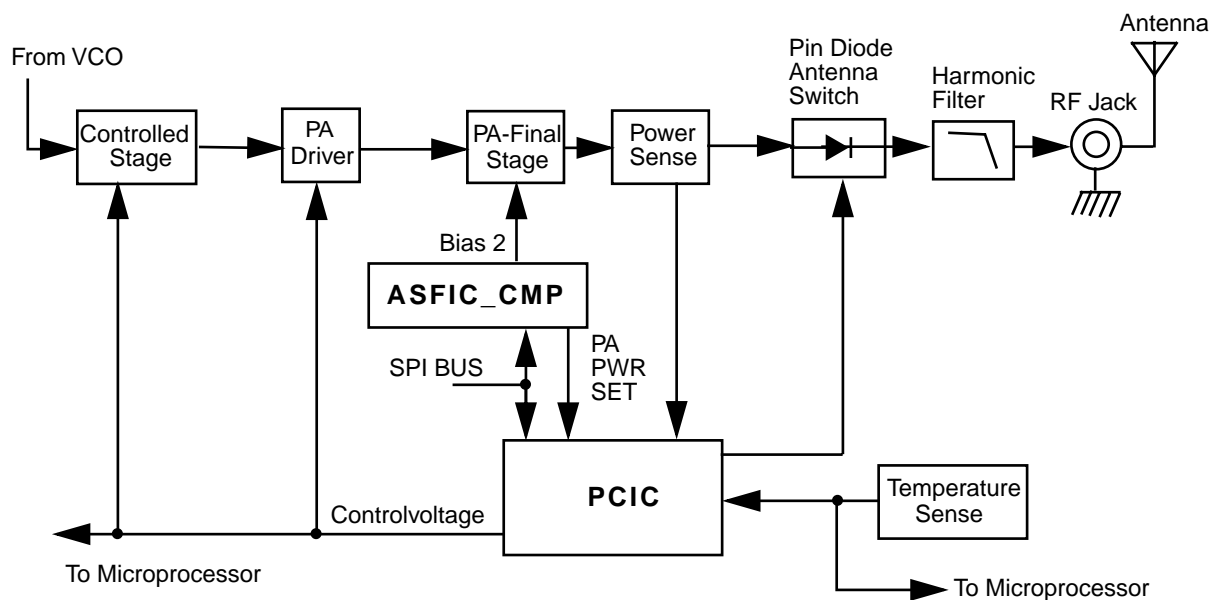

Figure 2-1 VHF Transmitter Block Diagram

Devices U3401, Q3421 and Q3441 are surface mounted. A pressure pad between board and the radio's cover provides good thermal contact between the devices and the chassis.

3.1 First Power Controlled Stage

The first stage (U3401) is a 20dB gain integrated circuit containing two LDMOS FET amplifier stages. It amplifies the RF signal from the VCO (TXINJ). The output power of stage U3401 is controlled by a DC voltage applied to pin 1 from the op-amp U3402-1, pin 1. The control voltage simultaneously varies the bias of two FET stages within U3401. This biasing point determines the overall gain of U3401 and therefore its output drive level to Q3421, which in turn controls the output power of the PA.

Op-amp U3402-1 monitors the drain current of U3401 via resistor R3444 and adjusts the bias voltage of U3401 so that the current remains constant. The PCIC (U3501) provides a DC output voltage at pin 4 (INT) which sets the reference voltage of the current control loop. A raising power output causes the DC voltage from the PCIC to fall, and U3402-1 adjusts the bias voltage for a lower drain current to lower the gain of the stage.

In receive mode the DC voltage from PCIC pin 23 (RX) turns on Q3442, which in turn switches off the biasing voltage to U3401.

Switch S3440 is a pressure pad with a conductive strip which connects two conductive areas on the board when the radio's cover is properly screwed to the chassis. When the cover is removed, S3440 opens and the resulting high voltage level at the inverting inputs of the current control op-amps U3402-1 & 2 switches off the biasing of U3401 and Q3421. This prevents transmitter key up while the devices do not have proper thermal contact to the chassis.

3.2 Power Controlled Driver Stage

The next stage is an LDMOS device (Q3421) providing a gain of 12dB. This device requires a positive gate bias and a quiescent current flow for proper operation. The bias is set during transmit mode by the drain current control op-amp U3402-2, and fed to the gate of Q3421 via the resistive network R3429, R3418, R3415 and R3416.

Op-amp U3402-2 monitors the drain current of U3421 via resistors R3424-27 and adjusts the bias voltage of Q3421 so that the current remains constant. The PCIC (U3501) provides a DC output voltage at pin 4 (INT) which sets the reference voltage of the current control loop. A raising power output causes the DC voltage from the PCIC to fall, and U3402-2 adjusts the bias voltage for a lower drain current to lower the gain of the stage.

In receive mode the DC voltage from PCIC pin 23 (RX) turns on Q3422, which in turn switches off the biasing voltage to Q3421.

3.3 Final Stage

The final stage is an LDMOS device (Q3441) providing a gain of 12dB. This device also requires a positive gate bias and a quiescent current flow for proper operation. The voltage of the line MOSBIAS_2 is set in transmit mode by the ASFIC and fed to the gate of Q3441 via the resistive network R3404, R3406, and R3431-5. This bias voltage is tuned in the factory. If the transistor is replaced, the bias voltage must be tuned using the Customer Programming Software (CPS). Care must be taken not to damage the device by exceeding the maximum allowed bias voltage. In receive mode U3402-2 pulls the bias voltage to low via D3401. The device's drain current is drawn directly from the radio's DC supply voltage input, PASUPVLTG, via L3436 and L3437.

A matching network consisting of C3441-49, L3443, and two striplines, transforms the impedance to 50 ohms and feeds the directional coupler.

3.4 Directional Coupler

The directional coupler is a microstrip printed circuit, which couples a small amount of the forward power delivered by Q3441. The coupled signal is rectified by D3451. The DC voltage is proportional to the RF output power and feeds the RFIN port of the PCIC (U3501 pin 1). The PCIC controls the gain of stage U3401 and Q3421 as necessary to hold this voltage constant, thus ensuring the forward power out of the radio to be held to a constant value.

3.5 Antenna Switch

The antenna switch consists of two PIN diodes, D3471 and D3472. In the receive mode, both diodes are off. Signals applied at the antenna jack J3401 are routed, via the harmonic filter, through network L3472, C3474 and C3475, to the receiver input. In the transmit mode, K9V1 turns on Q3471 which enables current sink Q3472, set to 96 mA by R3473 and VR3471. This completes a DC path from PASUPVLTG, through L3437, D3471, L3472, D3472, L3471, R3474 and the current sink, to ground. Both diodes are forward biased into conduction. The transmitter RF from the directional coupler is routed via D3471 to the harmonic filter and antenna jack. D3472 also conducts, shunting RF power and preventing it from reaching the receiver port (RXIN). L3472 is selected to appear as a $\lambda / 4$ wave transmission line, making the short circuit presented by D3472 appear as an open circuit at the junction of D3472 and the receiver path.

3.6 Harmonic Filter

Components L3491-L3493 and L3472, C3491-C3499 form a Chebychev low-pass filter to attenuate harmonic energy of the transmitter to specifications level. R3491 is used to drain electrostatic charge that might otherwise build up on the antenna. The harmonic filter also prevents high level RF signals above the receiver passband from reaching the receiver circuits, improving spurious response rejection.

3.7 Power Control

The transmitter uses the Power Control IC (PCIC, U3501) to control the power output of the radio. A portion of the forward RF power from the transmitter is sampled by the directional coupler and rectified, to provide a DC voltage to the RFIN port of the PCIC (pin 1) which is proportional to the sampled RF power.

The ASFIC (U0221) has internal digital to analog converters (DACs) which provide a reference voltage of the control loop to the PCIC via R3505. The reference voltage level is programmable through the SPI line of the PCIC. This reference voltage is proportional to the desired power setting of the transmitter, and is factory programmed at several points across the frequency range of the transmitter to offset frequency response variations of the transmitter's power detector circuit.

The PCIC provides a DC output voltage at pin 4 (INT) which sets the drain current of the first (U3401) and second (Q3421) transmitter stage via current control op-amps U3402-1 and U3402-2. This adjusts the transmitter power output to the intended value. Variations in forward transmitter power cause the DC voltage at pin 1 to change, and the PCIC adjusts the control voltage above or below its nominal value to raise or lower output power. Capacitors C3502-4, in conjunction with resistors and integrators within the PCIC, control the transmitter power-rise (key-up) and power-decay (de-key) characteristic to minimize splatter into adjacent channels. U3502 is a temperature-sensing device, which monitors the circuit board temperature in the vicinity of the transmitter driver and final devices, and provides a dc voltage to the PCIC (TEMP, pin 30) proportional to temperature. If the DC voltage produced exceeds the set threshold in the PCIC, the transmitter output power will be reduced so as to reduce the transmitter temperature.

4.0 VHF (136-174MHz) Frequency Synthesis

The frequency synthesizer subsystem consists of the reference oscillator (Y3261 or Y3263), the Low Voltage Fractional-N synthesizer (LVFRAC-N, U3201), and the voltage-controlled oscillators and buffer amplifiers (U3301, Q3301-2 and associated circuitry).

4.1 Reference Oscillator

The reference oscillator (Y3263) contains a temperature compensated crystal oscillator with a frequency of 16.8 MHz. An analog to digital (A/D) converter internal to U3201 (LVFRAC-N) and controlled by the microprocessor via serial interface (SRL) sets the voltage at the warp output of U3201 (pin 25) to set the frequency of the oscillator. The output of the oscillator (U3263 pin 3) is applied to pin 23 (XTAL1) of U3201 via R3263 and C3235.

In applications where less frequency stability is required, the oscillator inside U3201 is used along with an external crystal Y3261, varactor diode D3261, C3261, C3262 and R3262. In this case, Y3263, R3263, C3235 and C3251 are not used. When Y3263 is used, Y3261, D3261, C3261, C3262 and R3262 are not used, and C3263 is increased to 0.1 μ F.

4.2 Fractional-N Synthesizer

The LVFRAC-N synthesizer IC (U3201) consists of a pre-scaler, a programmable loop divider, control divider logic, a phase detector, a charge pump, an A/D converter for low frequency digital modulation, a balance attenuator to balance the high frequency analog modulation and low frequency digital modulation, a 13V positive voltage multiplier, a serial interface for control, and finally a super filter for the regulated 5 volts.

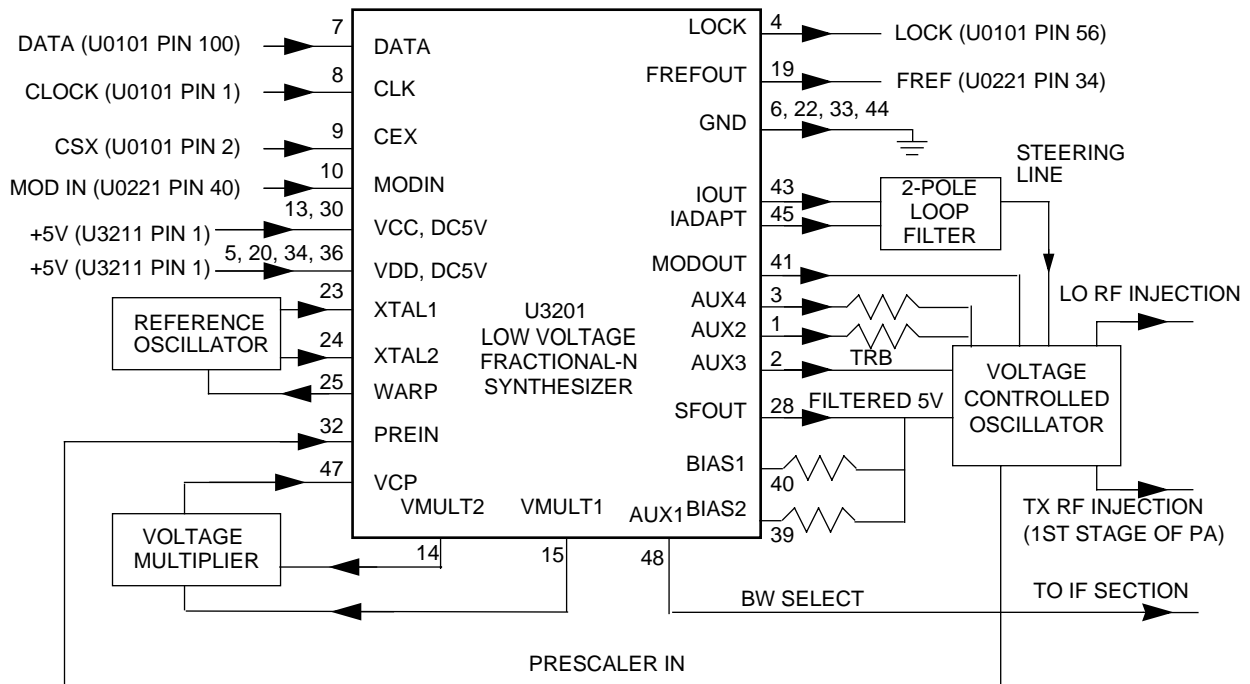

Figure 2-1 VHF Synthesizer Block Diagram

A voltage of 5V applied to the super filter input (U3201 pin 30) supplies an output voltage of 4.5 VDC (VSF) at pin 28. It supplies the VCO, VCO modulation bias circuit (via R3363) and the synthesizer charge pump resistor network (R3251, R3252). The synthesizer supply voltage is provided by the 5V regulator U3211.

In order to generate a high voltage to supply the phase detector (charge pump) output stage at pin VCP (U3201-47), a voltage of 13 VDC is being generated by the positive voltage multiplier circuitry (D3201, C3202, C3203). This voltage multiplier is basically a diode capacitor network driven by two (1.05MHz) 180 degrees out of phase signals (U3201-14 and -15).

Output LOCK (U3201-4) provides information about the lock status of the synthesizer loop. A high level at this output indicates a stable loop. IC U3201 provides the 16.8 MHz reference frequency at pin 19.

The serial interface (SRL) is connected to the microprocessor via the data line DATA (U3201-7), clock line CLK (U3201-8), and chip enable line CSX (U3201-9).

4.3 Voltage Controlled Oscillator (VCO)

The Voltage Controlled Oscillator (VCO) consists of the VCO/Buffer IC (VCOBIC, U3301), the TX and RX tank circuits, the external RX buffer stages, and the modulation circuitry.

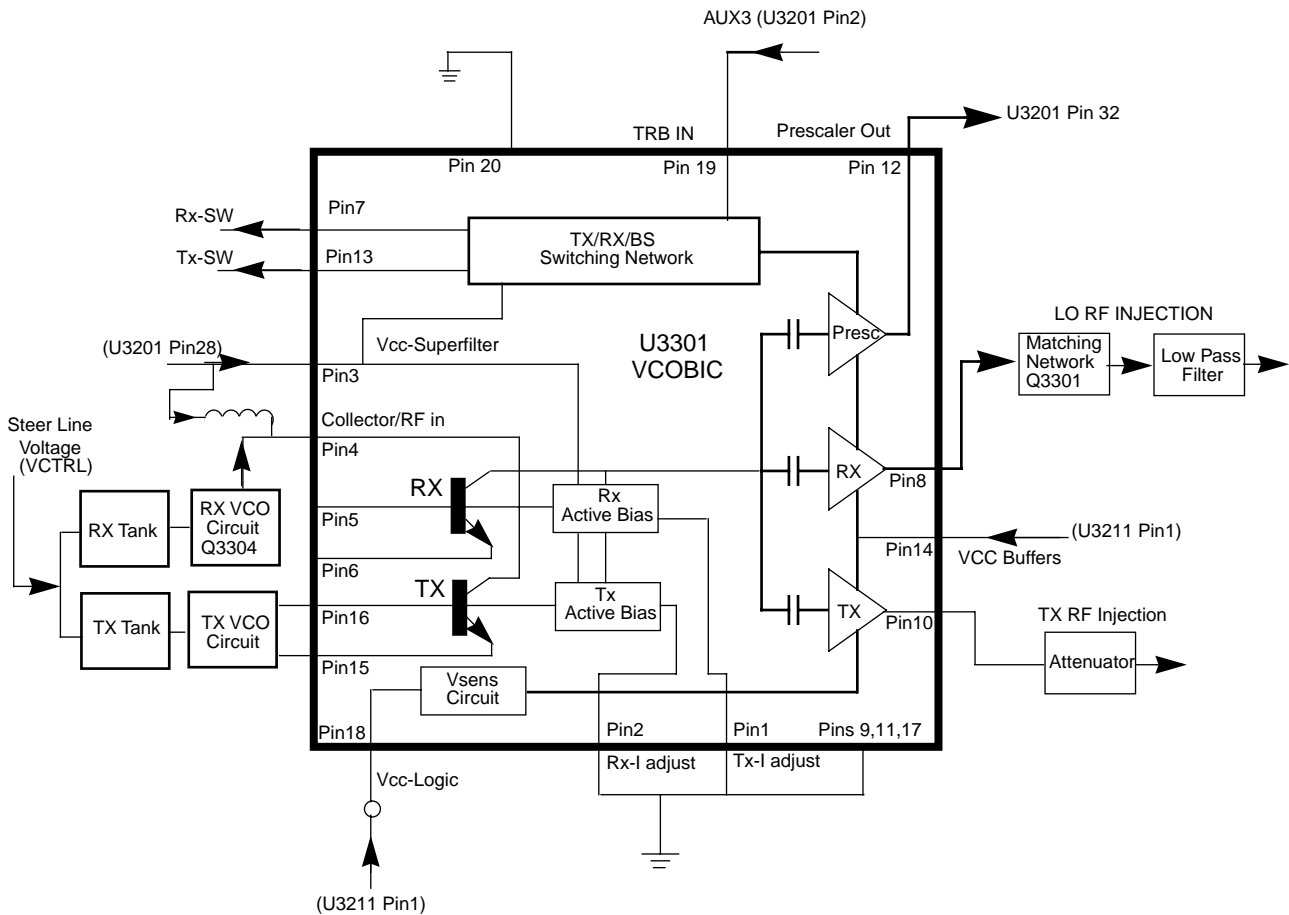

Figure 2-1 VHF VCO Block Diagram

The VCOBIC together with the Fractional-N synthesizer (U3201) generates the required frequencies in both the transmit and receive modes. The TRB line (U3301 pin 19) determines which tank circuits and internal buffers are to be enabled. A high level on TRB enables the TX tank and TX output (pin 10), and a low enables the RX tank and RX output (pin 8). A sample of the signal from the enabled RF output is routed from U3301 pin 12 (PRESC_OUT), via a low pass filter, to pin 32 of U3201 (PREIN).

A steering line voltage (VCTRL) between 2.5V and 11V at varactor diode D3361 will tune the full TX frequency range (TXINJ) from 136 MHz to 174 MHz, and at varactor diode D3341 will tune the full RX frequency range (RXINJ) from 181 MHz to 219 MHz. The RX tank circuit uses a Hartley configuration for wider bandwidth. For the RX tank circuit, an external transistor Q3304 is used for better side-band noise.

The external RX buffers (Q3301 and Q3302) are enabled by a high at U3301 pin 7 (RX_SWITCH) via transistor switch Q3303. In the TX mode, the modulation signal (VCOMOD) from the LVFRAC-N synthesizer IC (U3201 pin 41) is applied to varactor diode D3362, which modulates the TX VCO frequency via capacitor C3362. Varactor D3362 is biased for linearity from VSF.

4.4 Synthesizer Operation

The complete synthesizer subsystem consists of the low voltage FRAC-N (LVFRACN), the reference oscillator (a crystal oscillator with temperature compensation), charge pump circuitry, loop filter circuitry and a DC supply. The output signal PRESC from the VCOBIC (U3301 pin 12) is fed to U3201 pin 32 (PREIN) via a low pass filter (C3318, L3318 and C3226) which attenuates harmonics and provides the correct level to close the synthesizer loop.

The pre-scaler in the synthesizer (U3201) is a dual modulus type with selectable divider ratios. The divider ratio of the pre-scaler is controlled by the loop divider, which in turn receives its inputs via the SRL. The output of the pre-scaler is applied to the loop divider. The output of the loop divider is connected to the phase detector, which compares the loop divider's output signal with the reference signal. The reference signal is generated by dividing down the signal of the reference oscillator (Y3261 or Y3263).

The output signal of the phase detector is a pulsed DC signal which is routed to the charge pump. The charge pump outputs a current at U3201 pin 43 (IOUT). The loop filter (which consists of R3221-R3223 and C3221-C3224) transforms this current into a voltage that is applied to the varactor diodes (D3361 for transmit, D3341 for receive) to alter the output frequency of the appropriate VCO. The current can be set to a value fixed within the LVFRAC-N IC, or to a value determined by the currents flowing into BIAS 1 (U3201-40) or BIAS 2 (U3201-39). The currents are set by the value of R3251 and R3252 respectively. The selection of the three different bias sources is done by software programming.

To reduce synthesizer lock time when new frequency data has been loaded into the synthesizer, the magnitude of the loop current is increased by enabling the IADAPT pin (U3201-45) for a certain software programmable time (adapt mode). The adapt mode timer is started by a low to high transient of the CSX line. When the synthesizer is within the lock range, the current is determined only by the resistors connected to BIAS 1 and BIAS 2, or by the internal current source. A settled synthesizer loop is indicated by a high level signal at U3201-4 (LOCK).

The LOCK signal is routed to one of the μ P's ADC inputs (U0101-56). From the measured voltage, the μ P determines whether LOCK is active.

In order to modulate the PLL, the two spot modulation method is utilized. Via U3201 pin 10 (MODIN), the audio signal is applied to both the A/D converter (low frequency path) as well as the balance attenuator (high frequency path). The A/D converter changes the low frequency analog modulating

signal into a digital code that is applied to the loop divider, thereby causing the carrier to deviate. The balance attenuator is used to adjust the VCO's deviation sensitivity to high frequency modulating signals. The output of the balance attenuator is present at the MODOUT port (U3201-41) and connected to the VCO modulation diode D3362 via R3364.

5.0 VHF (136-174MHz) Transmitter Power Amplifier (PA) 45 W

The radio's 45 W PA is a four stage amplifier used to amplify the output from the VCOBIC to the radio transmit level. The line-up consists of three stages which utilize LDMOS technology, followed by a final stage using a bipolar device. The gain of the first stage (U3401) is adjustable, controlled by pin 4 of PCIC (U3501) via Q3501 and Q3502 (VCONT). It is followed by an LDMOS pre-driver stage (Q3421), an LDMOS driver stage (Q3431) and a bipolar final stage (Q3441).

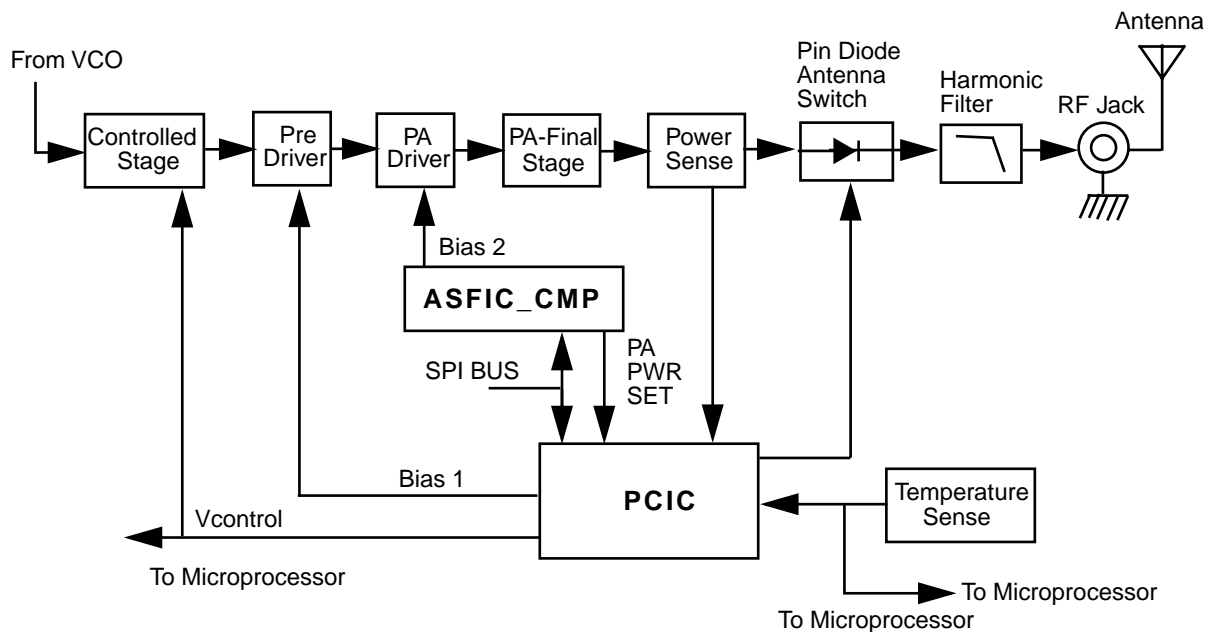

Figure 2-1 VHF Transmitter Block Diagram

Devices U3401 and Q3421 are surface mounted. The remaining devices are directly attached to the heat sink.

5.1 Power Controlled Stage

The first stage (U3401) is a 20dB gain integrated circuit containing two LDMOS FET amplifier stages. It amplifies the RF signal from the VCO (TXINJ). The output power of stage U3401 is controlled by a DC voltage applied to pin 1 from the power control circuit (U3501 pin 4, with transistors Q3501 and Q3502 providing current gain and level-shifting). The control voltage simultaneously varies the bias of two FET stages within U3401. This biasing point determines the overall gain of U3401 and therefore its output drive level to Q3421, which in turn controls the output power of the PA.

In receive mode the voltage control line is at ground level and turns off Q3501-2, which in turn switches off the biasing voltage to U3401.

5.2 Pre-Driver Stage

The next stage is an LDMOS device (Q3421) providing a gain of 13 dB. This device requires a positive gate bias and a quiescent current flow for proper operation. The voltage of the line PCIC_MOSBIAS_1 is set during transmit mode by the PCIC pin 24, and fed to the gate of Q3421 via the resistive network R3410, R3415, and R3416. The bias voltage is tuned in the factory.

5.3 Driver Stage

The following stage is an enhancement-mode N-Channel MOSFET device (Q3431) providing a gain of 10dB. This device also requires a positive gate bias and a quiescent current flow for proper operation. The voltage of the line MOSBIAS_2 is set in transmit mode by the ASFIC and fed to the gate of Q3431 via the resistive network R3404, R3406, and R3431-5. This bias voltage is also tuned in the factory. If the transistor is replaced, the bias voltage must be tuned using the Customer Programming Software (CPS). Care must be taken not to damage the device by exceeding the maximum allowed bias voltage. The device's drain current is drawn directly from the radio's DC supply voltage input, PASUPVLTG, via L3431 and L3432.

5.4 Final Stage

The final stage uses the bipolar device Q3441. The device's collector current is also drawn from the radio's DC supply voltage input. To maintain class C operation, the base is DC-grounded by a series inductor (L3441) and a bead (L3442). A matching network consisting of C3446-52, C3467, L3444-5, and two striplines, transforms the impedance to approximately 50 ohms and feeds the directional coupler.

5.5 Directional Coupler

The directional coupler is a microstrip printed circuit, which couples a small amount of the forward and reflected power delivered by Q3441. The coupled signals are rectified by D3451-2 and combined by R3463-4. The resulting DC voltage is proportional to RF output power and feeds the RFIN port of the PCIC (U3501 pin 1). The PCIC controls the gain of stage U3401 as necessary to hold this voltage constant, thus ensuring the forward power out of the radio to be held to a constant value.

An abnormally high reflected power level, such as may be caused by a damaged antenna, also causes the DC voltage applied to the PCIC to increase, and this will cause a reduction in the gain of U3401, reducing transmitter output power to prevent damage to the final device due to an improper load.

5.6 Antenna Switch

The antenna switch consists of two PIN diodes, D3471 and D3472. In the receive mode, both diodes are off. Signals applied at the antenna jack J3401 are routed, via the harmonic filter, through network L3472, C3474 and C3475, to the receiver input. In the transmit mode, K9V1 turns on Q3471 which enables current sink Q3472, set to 96 mA by R3473 and VR3471. This completes a DC path from PASUPVLTG, through L3473, D3471, L3477, L3472, D3472, L3471, R3474 and the current sink, to ground. Both diodes are forward biased into conduction. The transmitter RF from the directional coupler is routed via D3471 to the harmonic filter and antenna jack. D3472 also conducts, shunting RF power and preventing it from reaching the receiver port (RXIN). L3472 is selected to appear as a broadband $\lambda/4$ wave transmission line, making the short circuit presented by D3472 appear as an open circuit at the junction of D3472 and the receiver path.

5.7 Harmonic Filter

Components L3491-L3494 and C3489-C3498 form a nine-pole Chebychev low-pass filter to attenuate harmonic energy of the transmitter to specifications level. R3490 is used to drain electrostatic charge that might otherwise build up on the antenna. The harmonic filter also prevents high level RF signals above the receiver passband from reaching the receiver circuits, improving spurious response rejection.

5.8 Power Control

The transmitter uses the Power Control IC (PCIC, U3501) to control the power output of the radio. A portion of the forward and reflected RF power from the transmitter is sampled by the directional coupler, rectified and summed, to provide a DC voltage to the RFIN port of the PCIC (pin 1) which is proportional to the sampled RF power.

The ASFIC contains a digital to analog converter (DAC) which provides a reference voltage of the control loop to the PCIC via R3517. The reference voltage level is programmable through the SPI line of the PCIC. This reference voltage is proportional to the desired power setting of the transmitter, and is factory programmed at several points across the frequency range of the transmitter to offset frequency response variations of the transmitter's power detector circuitry.

The PCIC provides a DC output voltage at pin 4 (INT) which is amplified and shifted in DC level by stages Q3501 and Q3502. The 0 to 4 volt DC range at pin 4 of U3501 is translated to a 0 to 8.5 volt DC range at the output of Q3501, and applied as VCONT to the power-adjust input pin of the first transmitter stage U3401. This adjusts the transmitter power output to the intended value. Variations in forward or reflected transmitter power cause the DC voltage at pin 1 to change, and the PCIC adjusts the control voltage above or below its nominal value to raise or lower output power.

Capacitors C3502-4, in conjunction with resistors and integrators within the PCIC, control the transmitter power-rise (key-up) and power-decay (de-key) characteristic to minimize splatter into adjacent channels.

U3502 is a temperature-sensing device, which monitors the circuit board temperature in the vicinity of the transmitter driver and final devices, and provides a dc voltage to the PCIC (TEMP, pin 29) proportional to temperature. If the DC voltage produced exceeds the set threshold in the PCIC, the transmitter output power will be reduced so as to reduce the transmitter temperature.

TROUBLESHOOTING CHARTS

1.0 Troubleshooting Flow Chart for Receiver (Sheet 1 of 2)

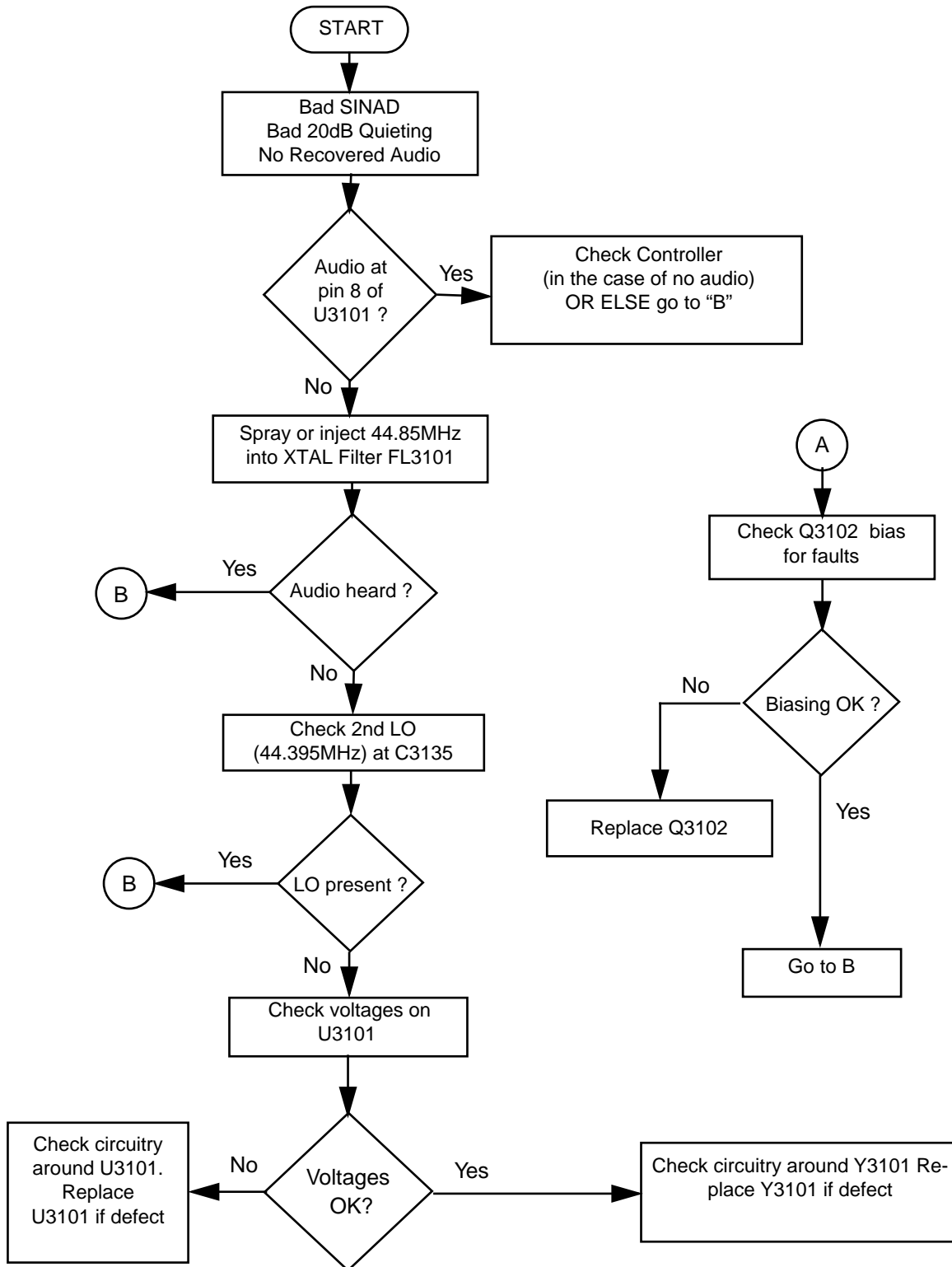

1.1 Troubleshooting Flow Chart for Receiver (Sheet 2 of 2)

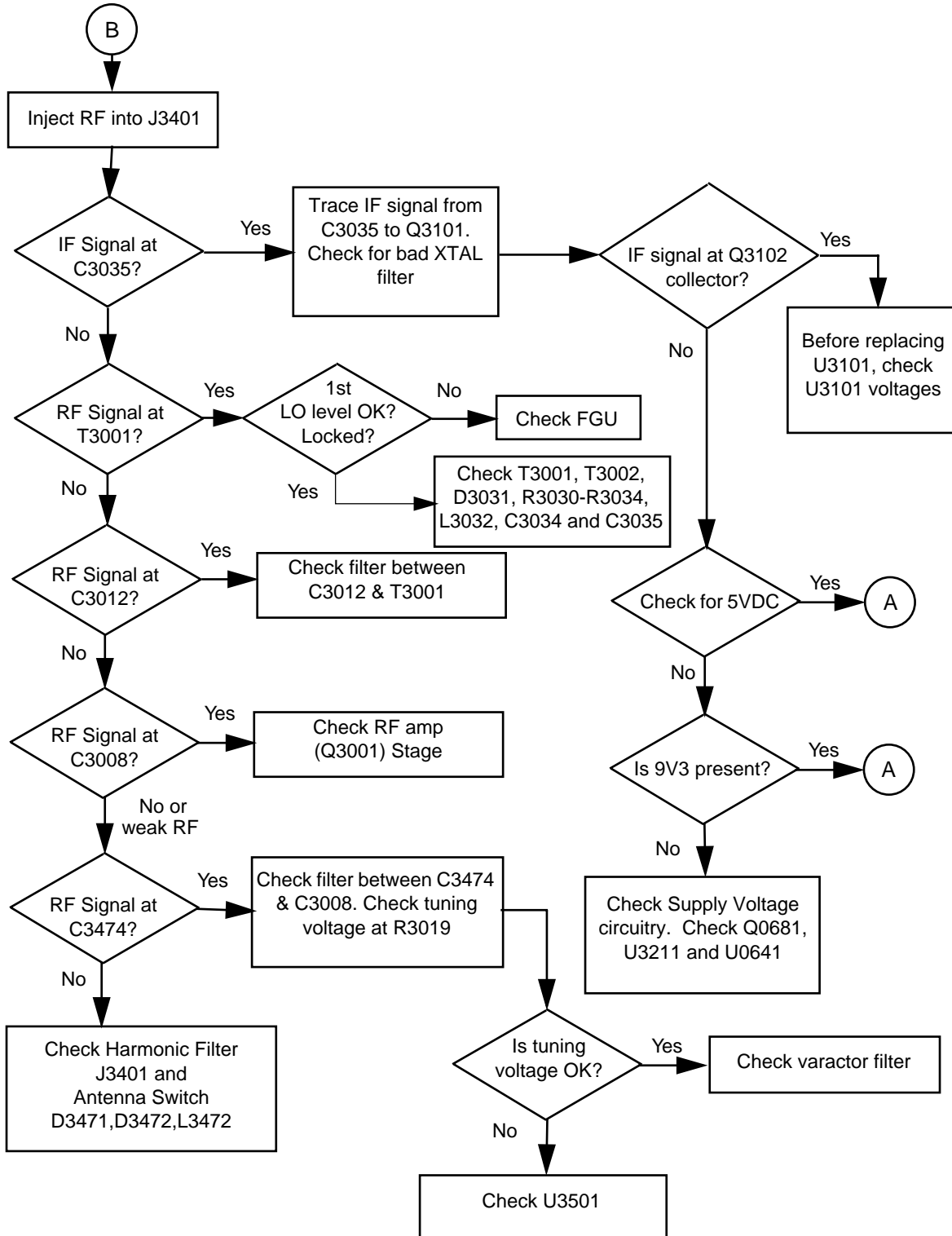

2.0 Troubleshooting Flow Chart for 25W Transmitter (Sheet 1 of 3)

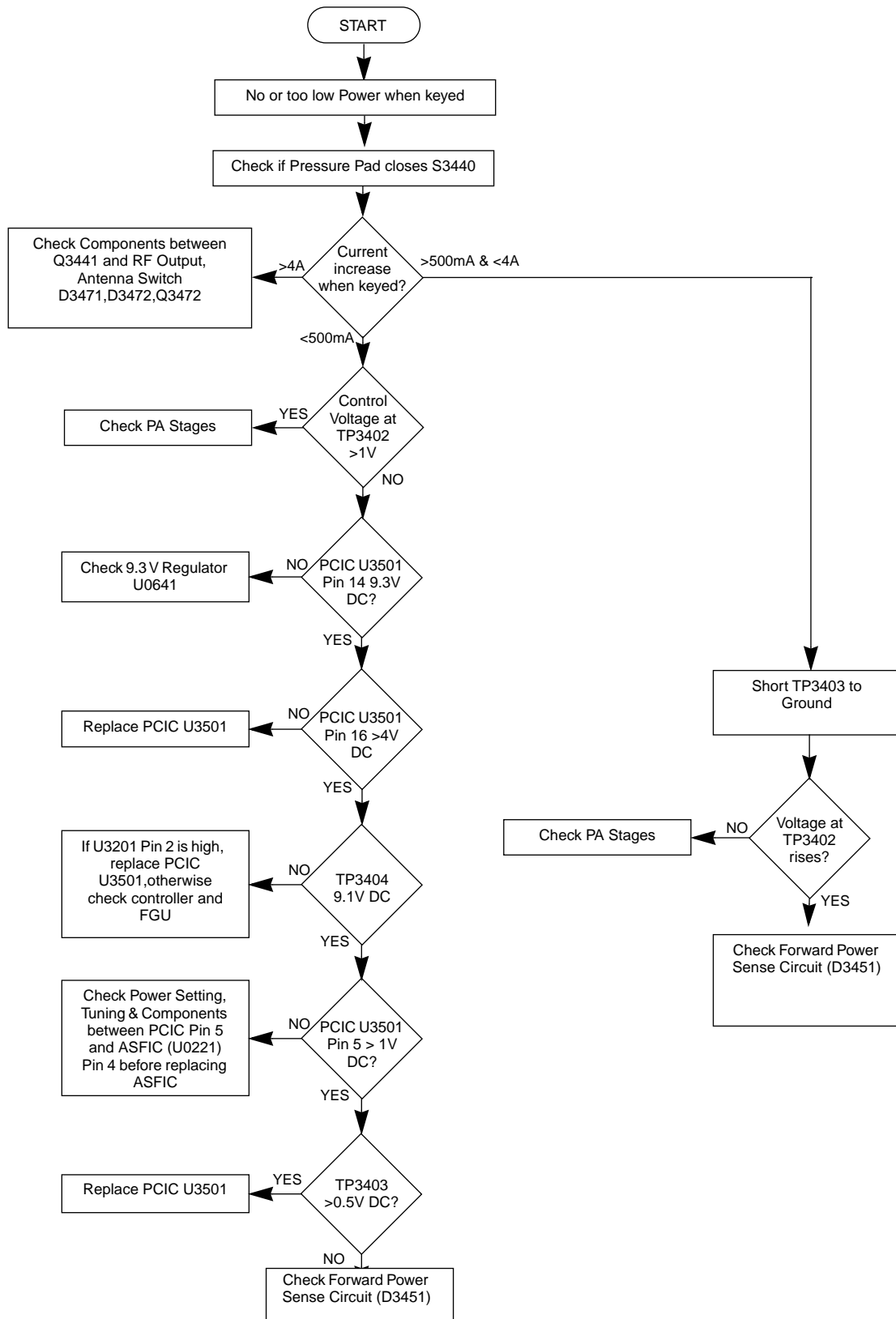

2.1 Troubleshooting Flow Chart for 25W Transmitter (Sheet 2 of 3)

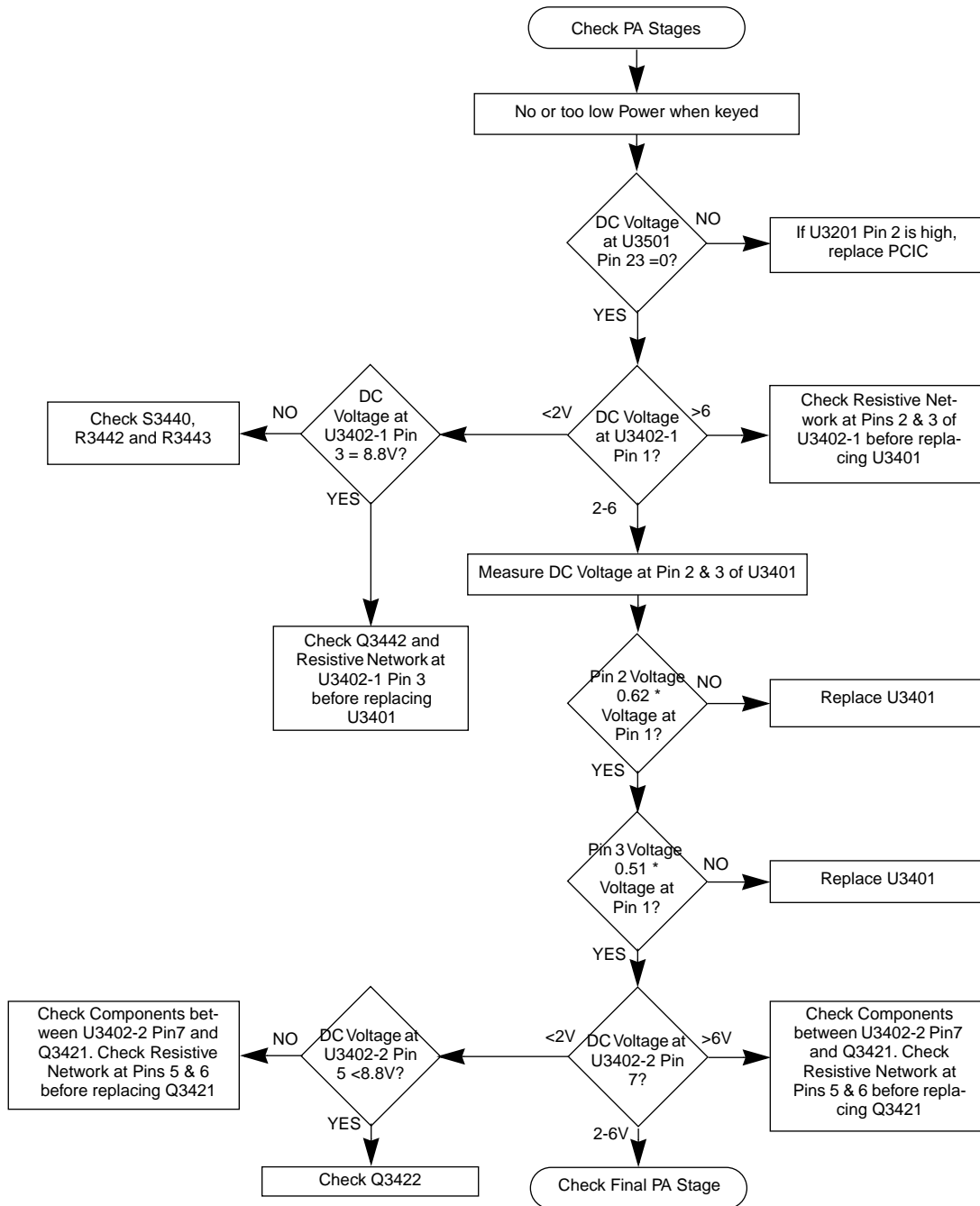

2.2 Troubleshooting Flow Chart for 25W Transmitter (Sheet 3 of 3)

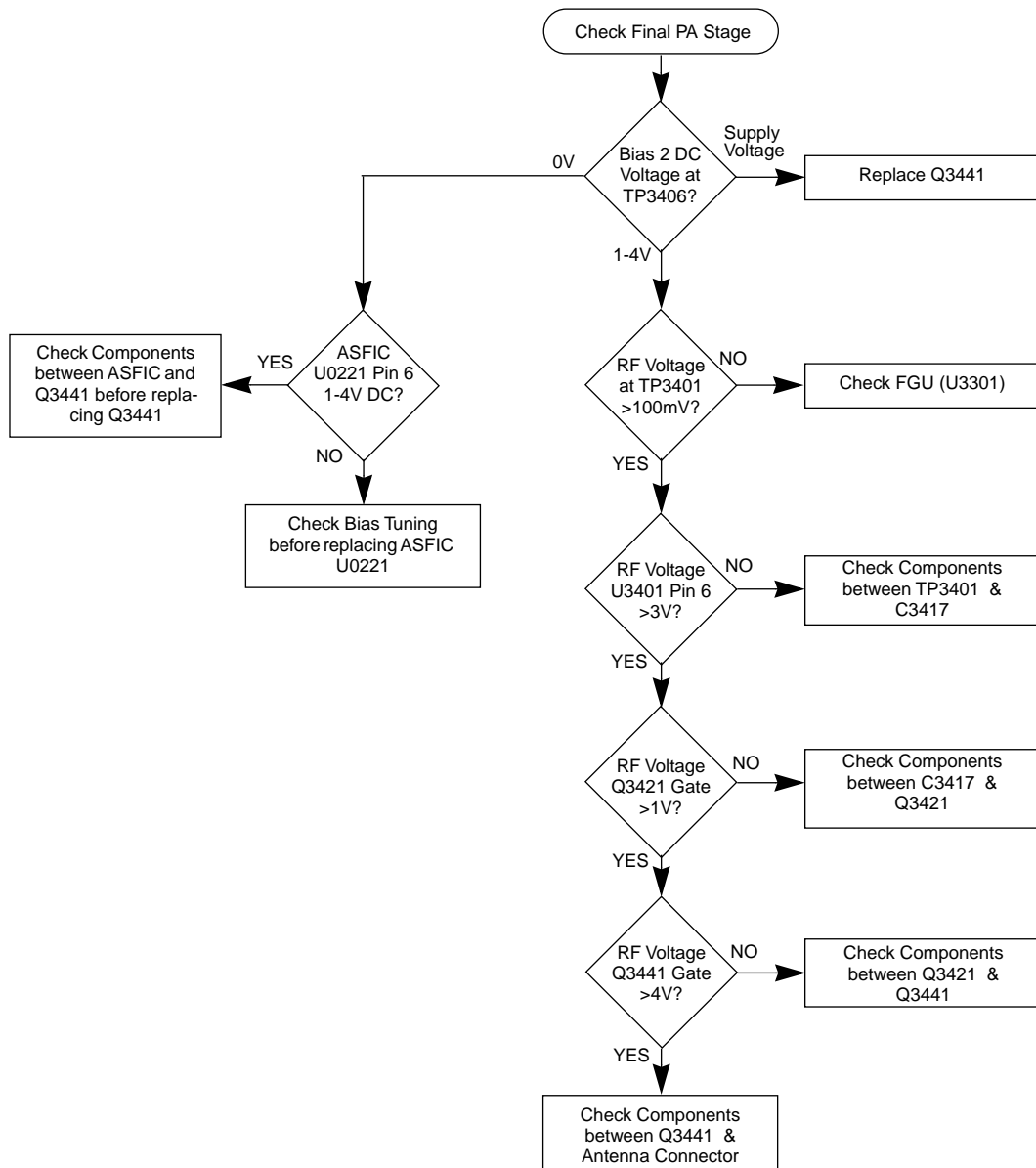

3.0 Troubleshooting Flow Chart for 45W Transmitter (Sheet 1 of 2)

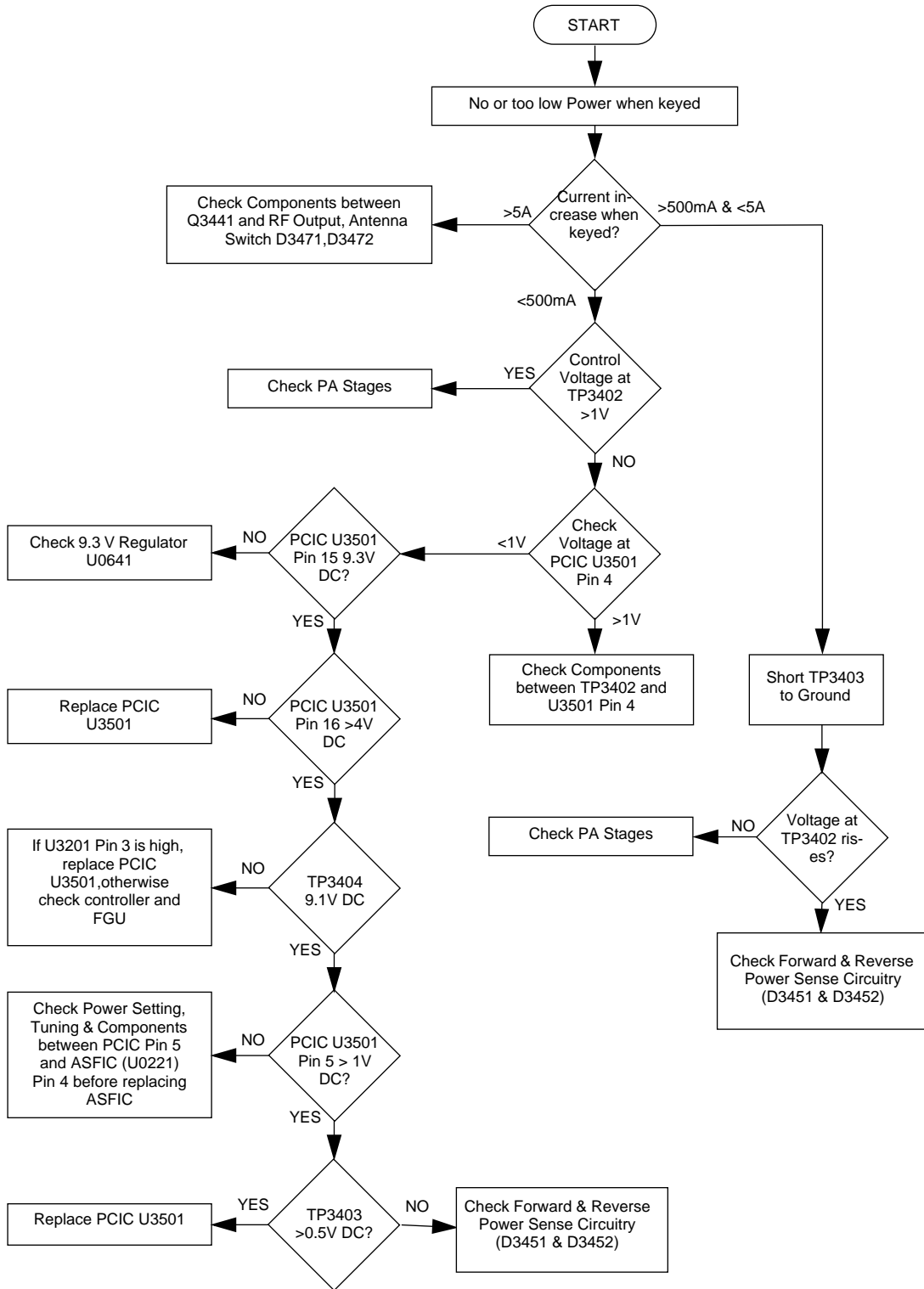

3.1 Troubleshooting Flow Chart for Transmitter (Sheet 2 of 2)

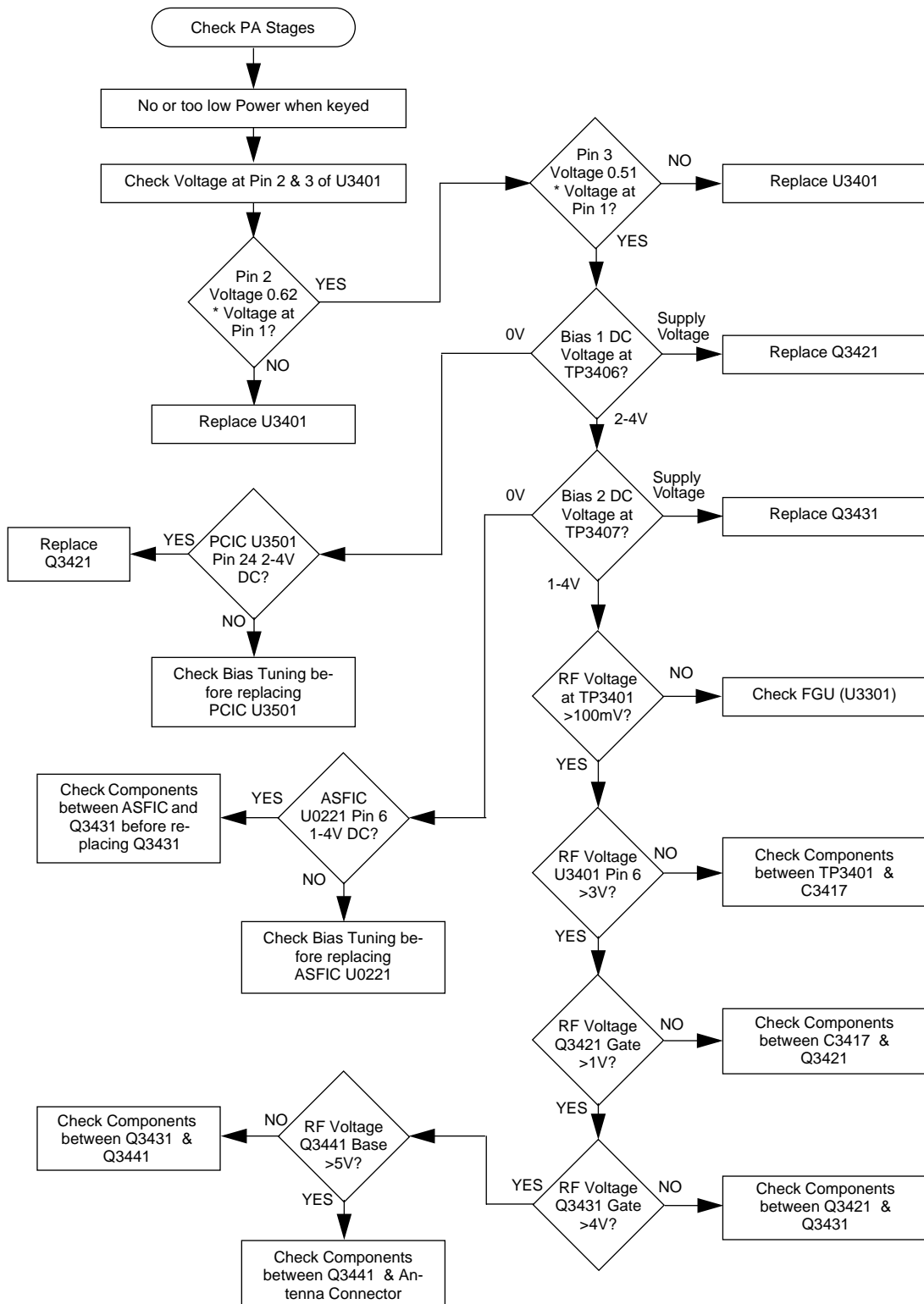

4.0 Troubleshooting Flow Chart for Synthesizer

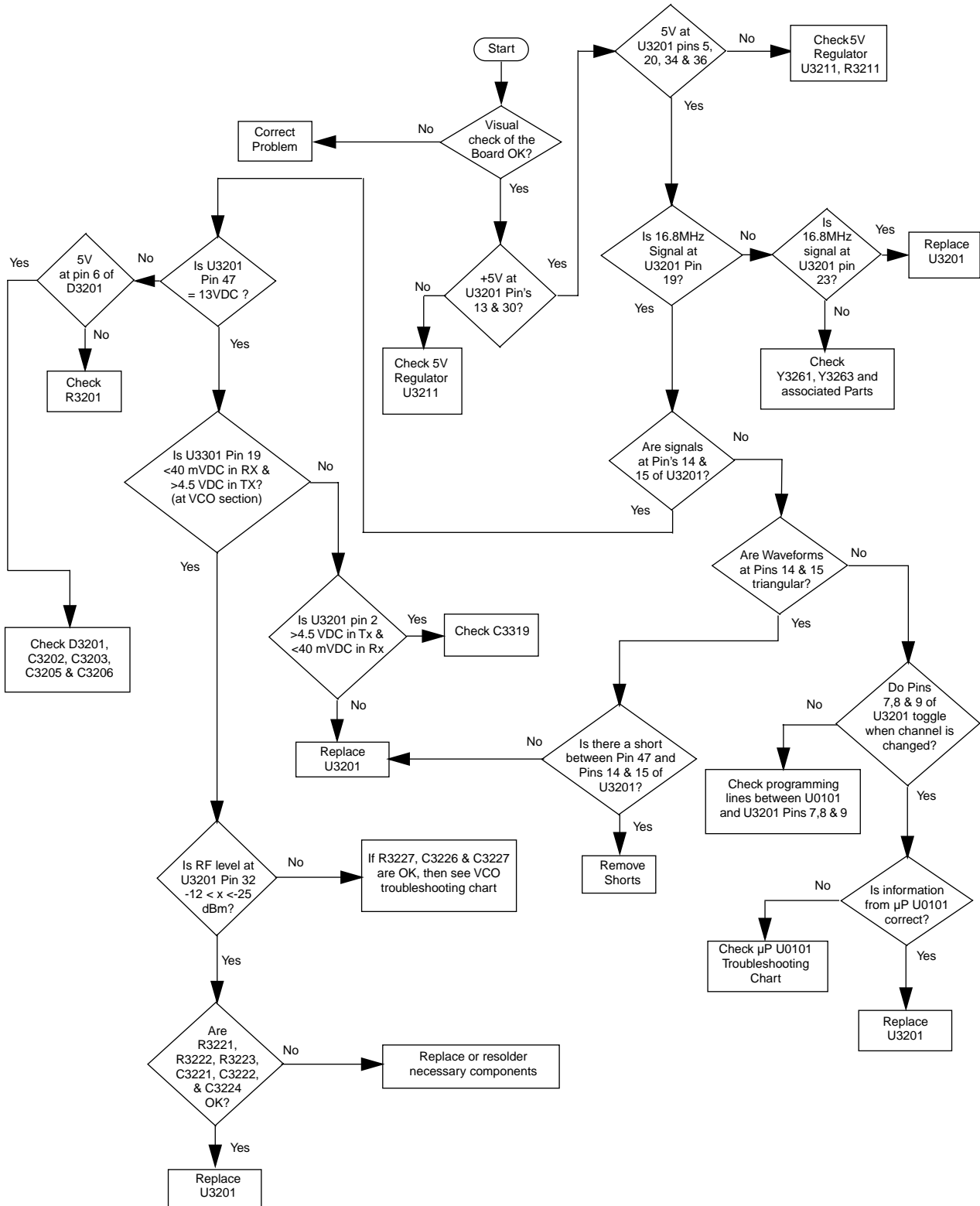

5.0 Troubleshooting Flow Chart for VCO

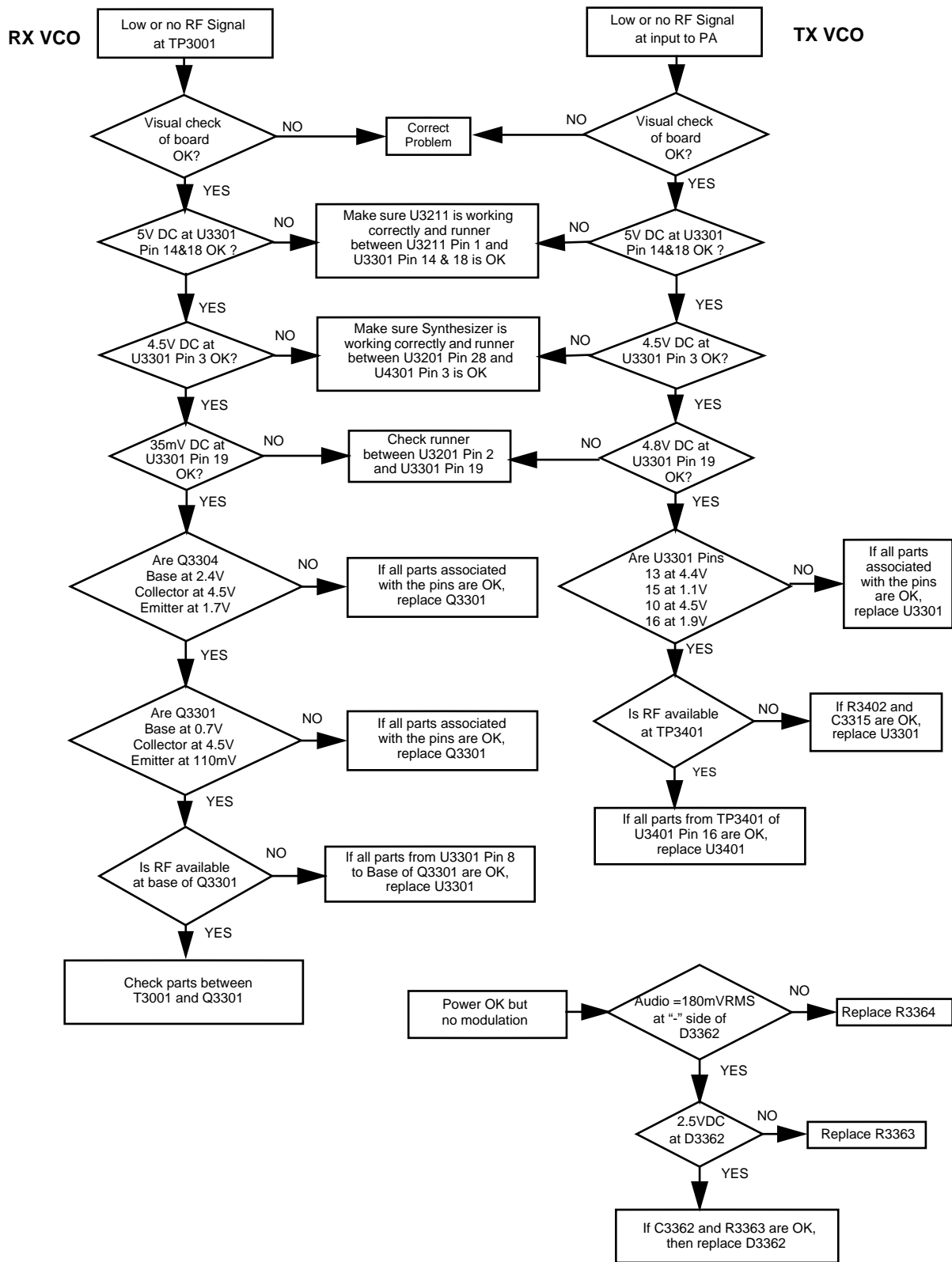

VHF PCB/SCHEMATICS/PARTS LISTS

1.0 Allocation of Schematics and Circuit Boards

1.1 Controller Circuits

The VHF circuits are contained on the printed circuit board (PCB) which also contains the Controller circuits. This Chapter shows the schematics for the VHF circuits only, refer to the Controller section for details of the related Controller circuits . The PCB component layouts and the Parts Lists in this Chapter show both the Controller and VHF circuit components. The VHF schematics and the related PCB and parts list are shown in the tables below.

Table 4-1 VHF 1-25W Diagrams and Parts Lists

PCB : 8486172B04 Main Board Top Side 8486172B04 Main Board Bottom Side	Page 4-3 Page 4-4
SCHEMATICS Power Amplifier 1 - 25W FRACN Voltage Controlled Oscillator Receiver Front End IF	Page 4-5 Page 4-6 Page 4-7 Page 4-8 Page 4-9
Parts List 8486172B04	Page 4-10
Controller version is T2	

Table 4-2 VHF 1-25W Diagrams and Parts Lists

PCB : 8486172B06 Main Board Top Side 8486172B06 Main Board Bottom Side	Page 4-13 Page 4-14
SCHEMATICS Power Amplifier 1 - 25W FRACN Voltage Controlled Oscillator Receiver Front End IF	Page 4-15 Page 4-16 Page 4-17 Page 4-18 Page 4-19
Parts List 8486172B06	Page 4-20
Controller version is T5	

Table 4-3 VHF 1-25W Diagrams and Parts Lists

PCB : 8486172B07 Main Board Top Side 8486172B07 Main Board Bottom Side	Page 4-23 Page 4-24
SCHEMATICS Power Amplifier 1 - 25W Voltage Controlled Oscillator Receiver Front End IF FRACN	Page 4-15 Page 4-17 Page 4-18 Page 4-25 Page 4-26
Parts List: 8486172B07	Page 4-27
Controller version is T7	

Table 4-4 VHF 1-25W Diagrams and Parts Lists

PCB : 8486172B08 Main Board Top Side 8486172B08 Main Board Bottom Side	Page 4-31 Page 4-32
SCHEMATICS Power Amplifier 1 - 25W Voltage Controlled Oscillator Receiver Front End IF FRACN	Page 4-33 Page 4-34 Page 4-35 Page 4-36 Page 4-37
Parts List: 8486172B08	Page 4-38
Controller version is T9	

Table 4-5 VHF 25-45W Diagrams and Parts Lists

PCB : 8486140B12 Main Board Top Side 8486140B12 Main Board Bottom Side 8486140B13 Main Board Top Side 8486140B13 Main Board Bottom Side	Page 4-41 Page 4-42 Page 4-47 Page 4-48
SCHEMATICS Power Amplifier 25 - 45W FRACN Voltage Controlled Oscillator Receiver Front End IF	Page 4-43 Page 4-26 Page 4-17 Page 4-18 Page 4-25
Parts List: 8486140B12 Parts List: 8486140B13	Page 4-44 Page 4-49
Controller T6 is used on PCB 8486140B12 Controller T9 is used on PCB 8486140B13	

2.0 VHF 1-25W PCB 8486172B04 / Schematics

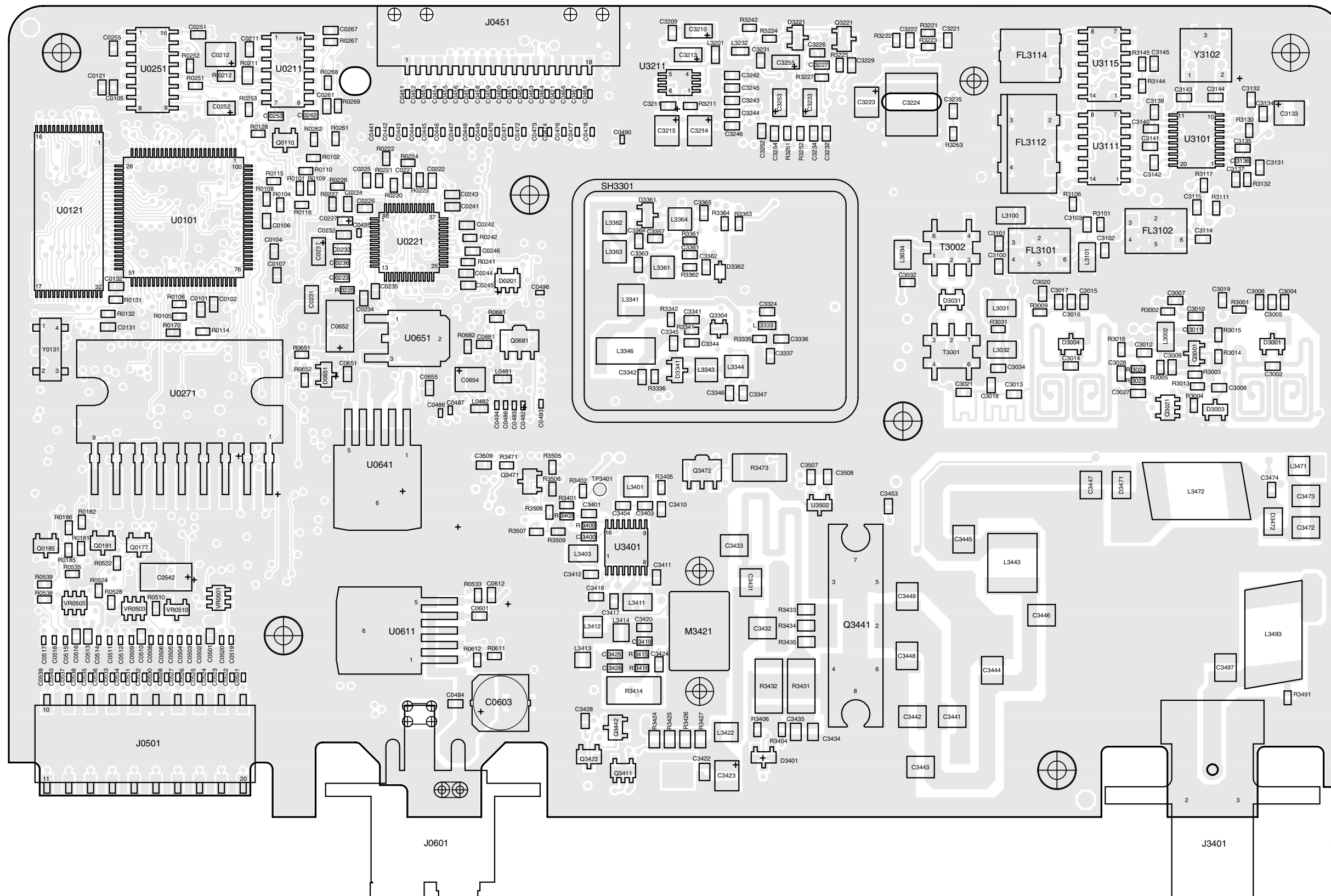

**VHF (136-174 MHz) 1-25W
8486172B04 Top Side**

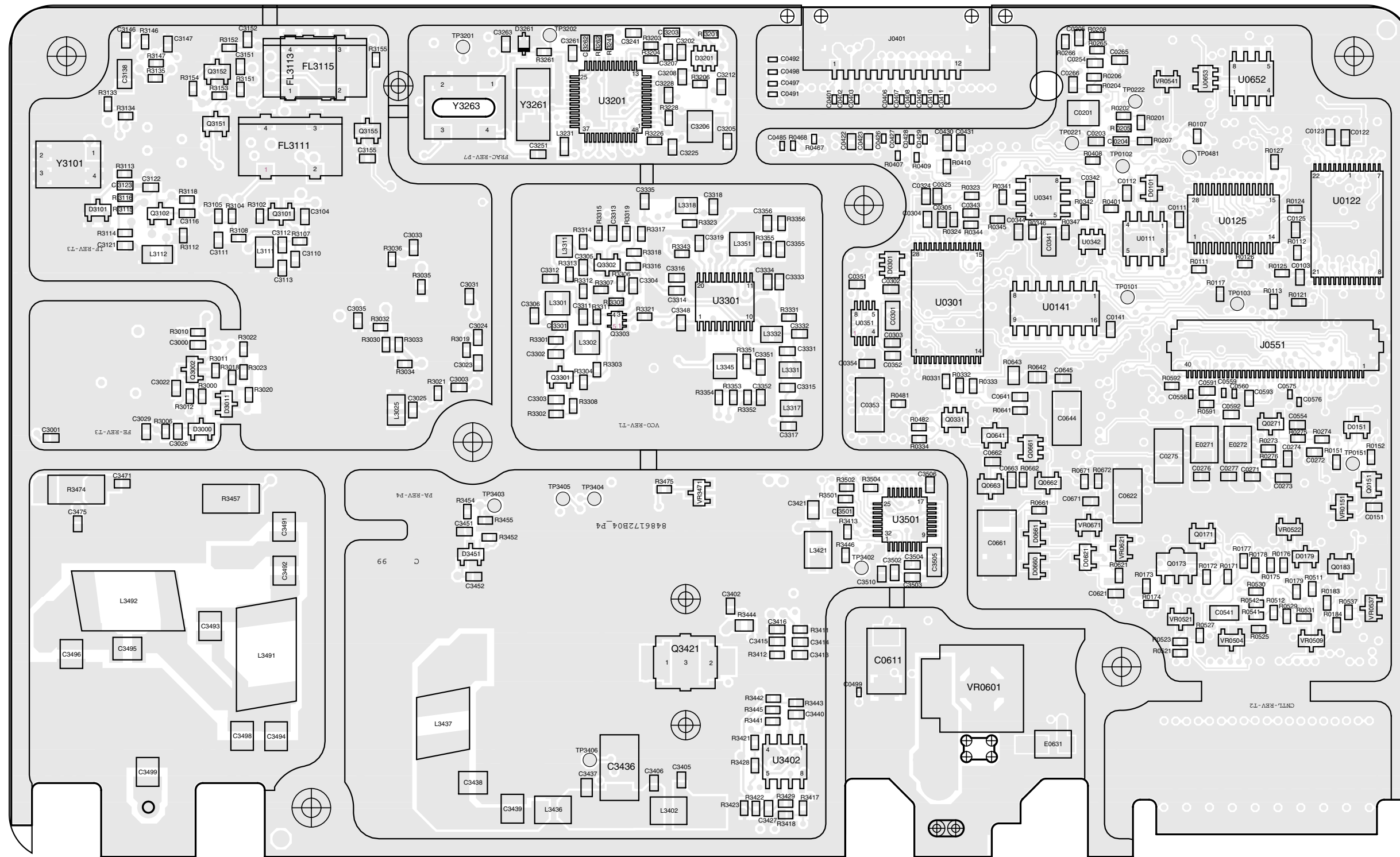

ZWG01300398-P4

VHF (136-174 MHz) 1-25W 8486172B04 Bottom Side

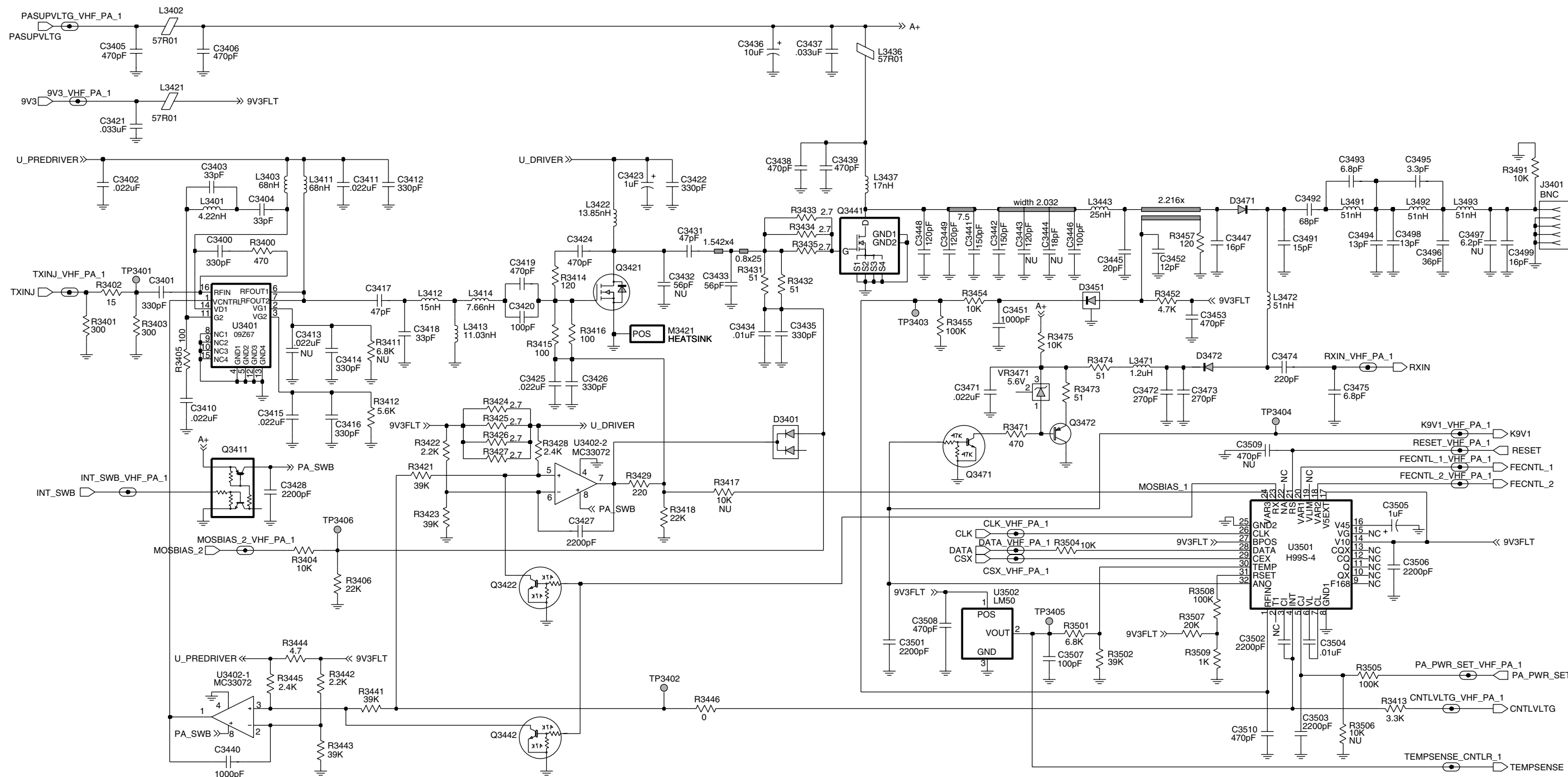

ZWG0130392-P4

VHF (136-174 MHz) Power Amplifier 1 - 25W

VHF (136-174 MHz) Power Amplifier 1 - 25W

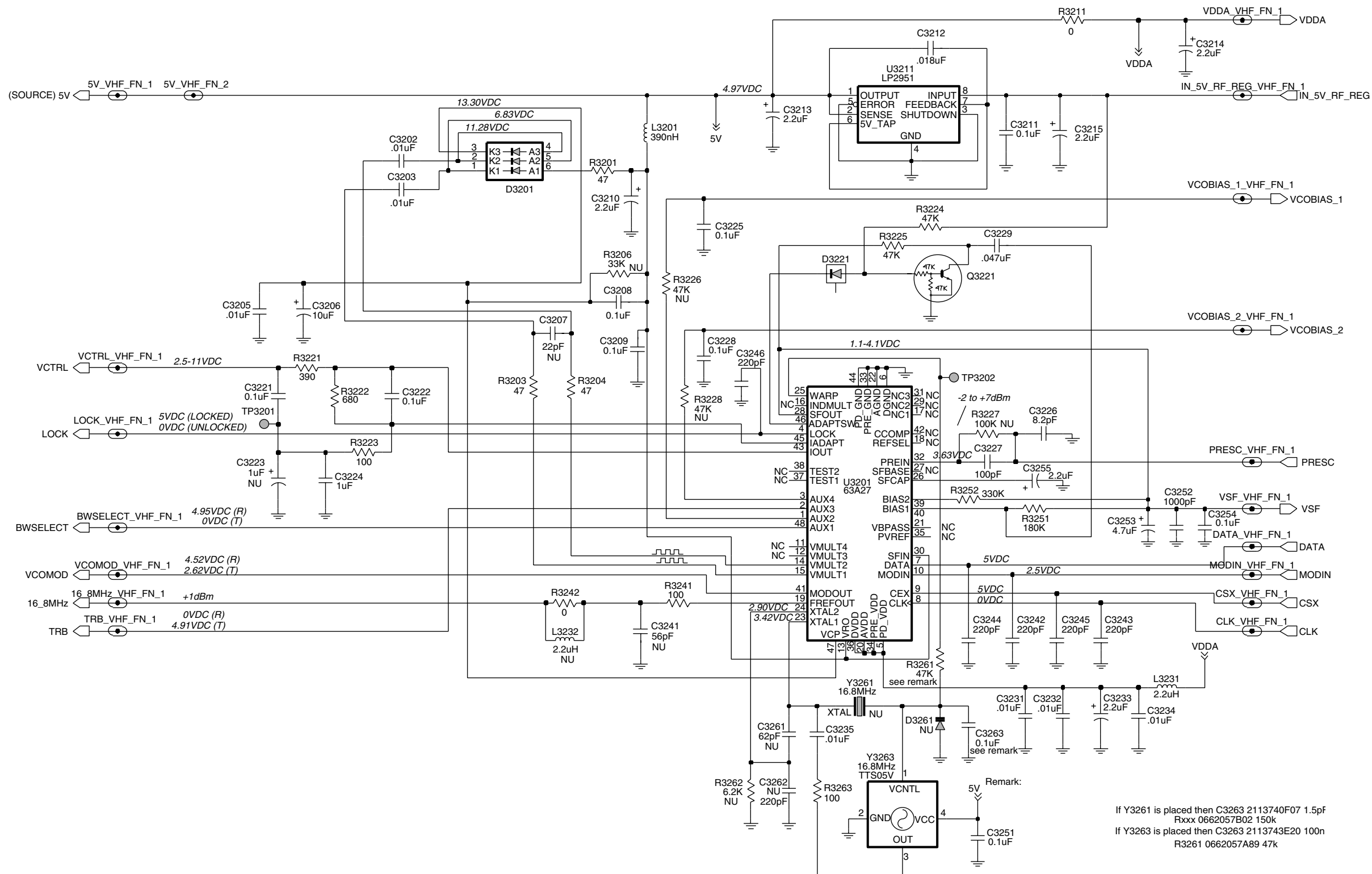

ZWG0130393-P4

VHF (136-174 MHz) FRACN

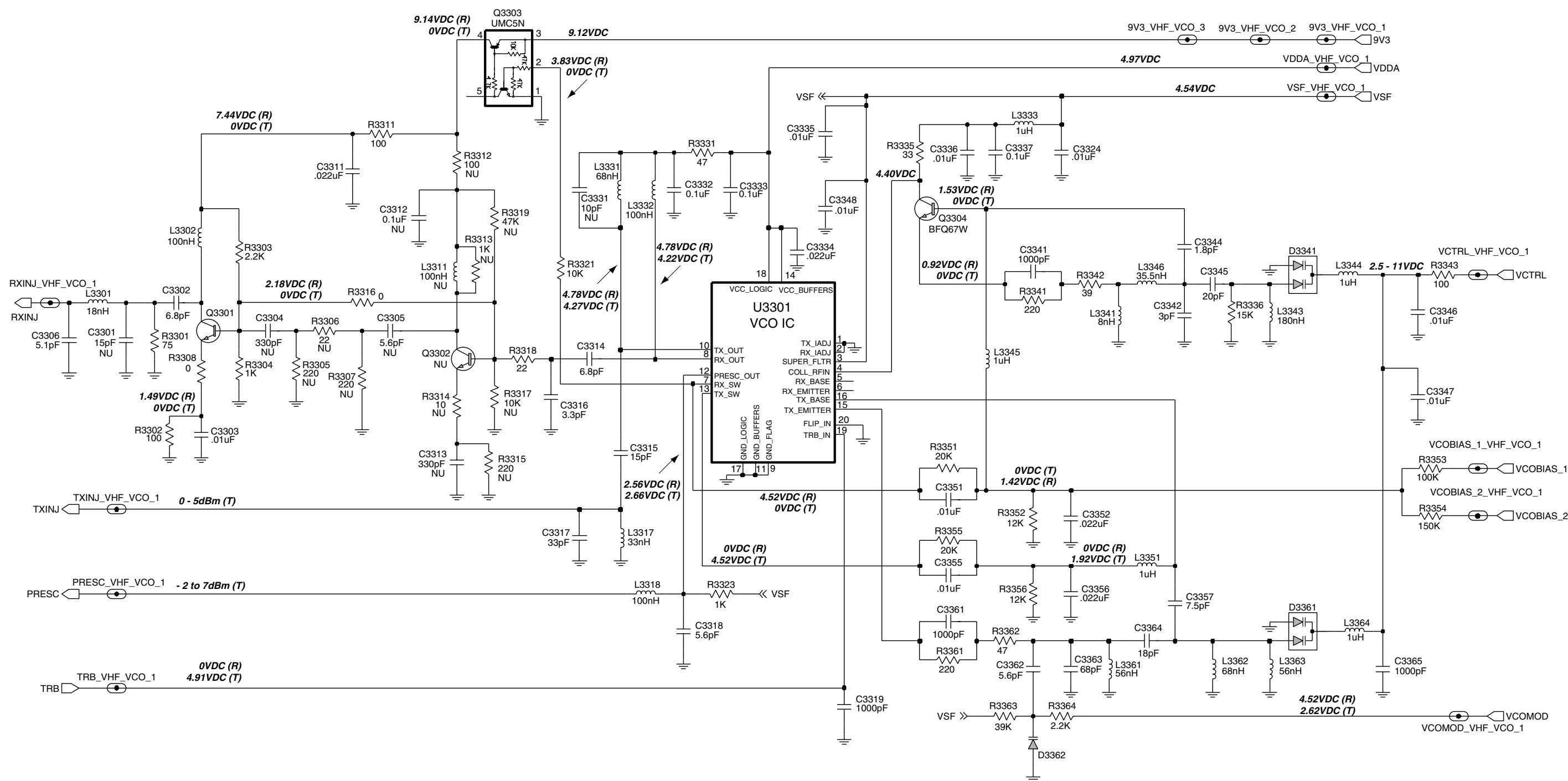

ZWG0130394-P4

VHF (136-174 MHz) Voltage Controlled Oscillator

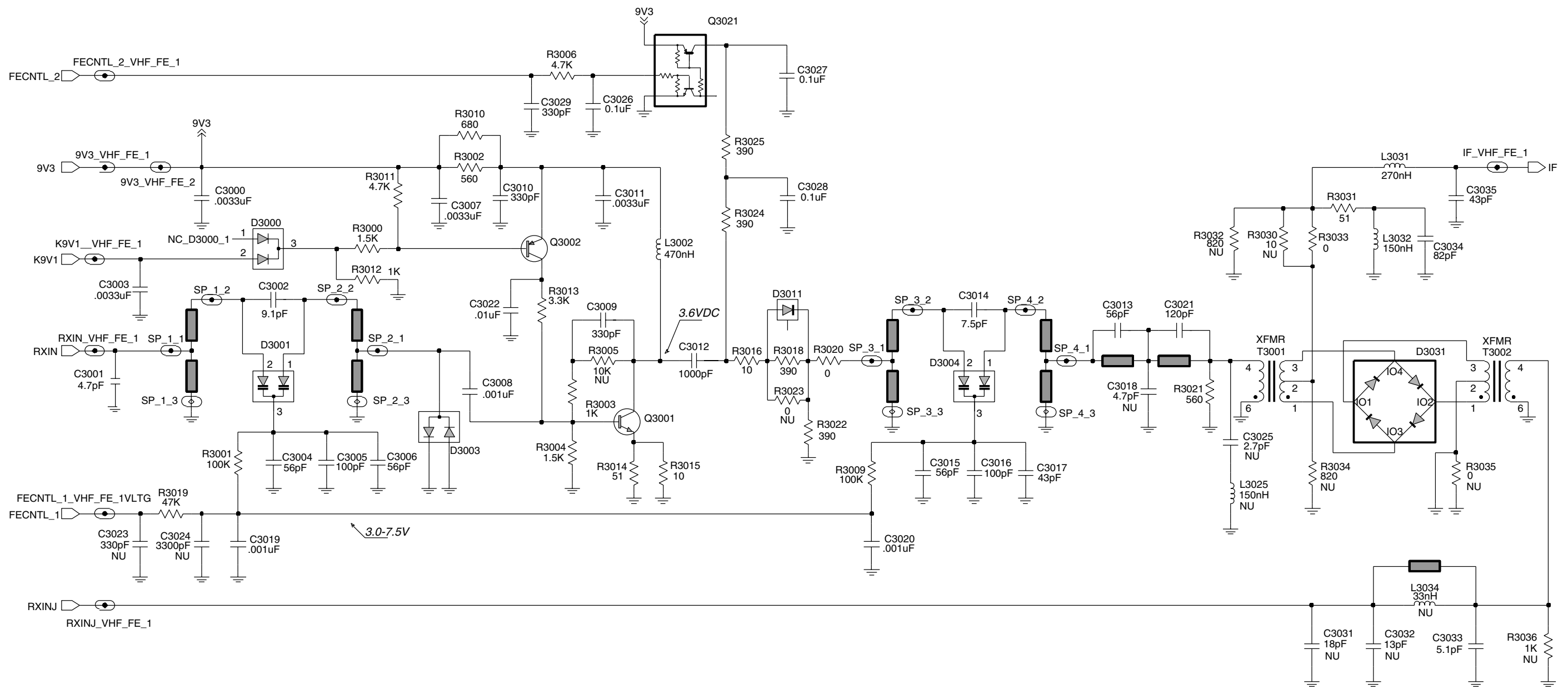

VHF (136-174 MHz) Receiver Front End

ZWG0130395-P4

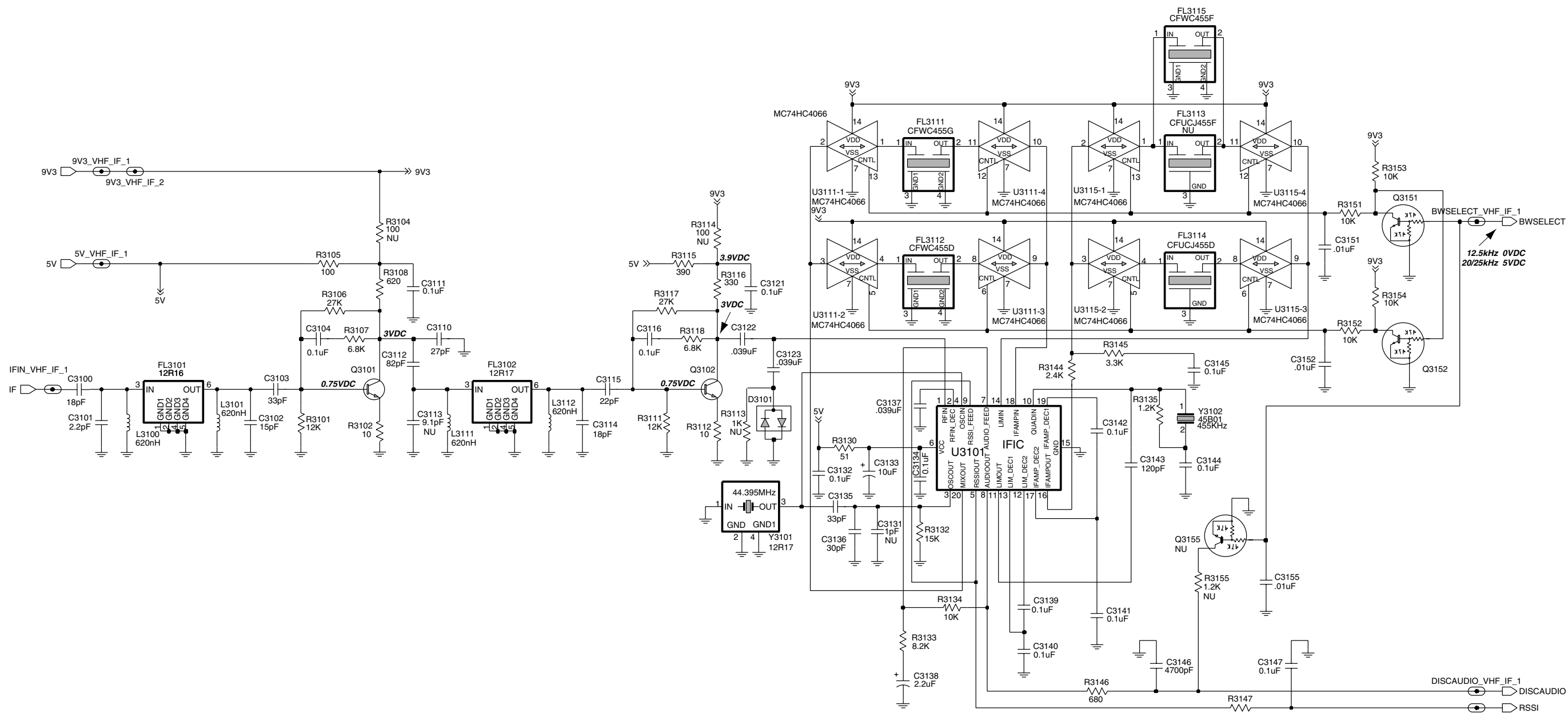

ZWG0130396-P4

VHF (136-174 MHz) IF

2.1 VHF PCB 8486172B04 Parts List 1-25W

Circuit Ref	Motorola Part No.	Description
C3000	2113741F37	3.3nF 50V
C3001	2113740F19	4.7pF 5% 50V
C3002	2113740F26	9.1pF 5% 50V
C3003	2113741F37	3.3nF 50V
C3004	2113740F45	56pF 5% 50V
C3005	2113740F51	100pF 5% 50V
C3006	2113740F45	56pF 5% 50V
C3007	2113741F37	3.3nF 50V
C3008	2113741F25	1nF 50V
C3009	2113741F13	330pF 50V
C3010	2113741F13	330pF 50V
C3011	2113741F37	3.3nF 50V
C3012	2113741F25	1nF 50V
C3013	2113740F45	56pF 5% 50V
C3014	2113740F24	7.5pF 5% 50V
C3015	2113740F45	56pF 5% 50V
C3016	2113740F51	100pF 5% 50V
C3017	2113740F42	43pF 5% 50V
C3019	2113741F25	1nF 50V
C3020	2113741F25	1nF 50V
C3021	2113740F53	120pF 5% 50V
C3022	2113741F49	10nF 50V
C3026	2113741F25	1nF 50V
C3027	2113741F25	1nF 50V
C3033	2113740F20	5.1pF 5% 50V
C3034	2113740F49	82pF 5% 50V
C3035	2113740F42	43pF 5% 50V
C3100	2113740F33	18pF 5% 50V
C3101	2113740F11	2.2pF 5% 50V
C3102	2113740F31	15pF 5% 50V
C3103	2113740F39	33pF 5% 50V
C3104	2113743E20	100nF
C3110	2113740F37	27pF 5% 50V
C3111	2113743E20	100nF
C3112	2113740F49	82pF 5% 50V
C3114	2113740F33	18pF 5% 50V
C3115	2113740F35	22pF 5% 50V
C3116	2113743E20	100nF
C3121	2113743E20	100nF
C3122	2113743E11	39nF 10%
C3123	2113743E11	39nF 10%
C3132	2113743E20	100nF
C3133	2311049A57	TANT CP 10uF 10% 16V
C3134	2113743E20	100nF
C3135	2113740L30	33pF 2%
C3136	2113740L29	30pF 2%
C3137	2113743E11	39nF 10%
C3138	2311049A40	TANT CP 2.2uF 10% 10V
C3139	2113743E20	100nF
C3140	2113743E20	100nF

Circuit Ref	Motorola Part No.	Description
C3141	2113743E20	100nF
C3142	2113743E20	100nF
C3143	2113740F53	120pF 5% 50V
C3144	2113743E20	100nF
C3145	2113743E20	100nF
C3146	2113741F41	4.7nF 50V
C3147	2113743E20	100nF
C3151	2113741F49	10nF 50V
C3152	2113741F49	10nF 50V
C3155	2113741F49	10nF 50V
C3202	2113741F49	10nF 50V
C3203	2113741F49	10nF 50V
C3205	2113741F49	10nF 50V
C3206	2311049A57	TANT CP 10uF 10% 16V
C3208	2113743E20	100nF
C3209	2113743E20	100nF
C3210	2311049A40	TANT CP 2.2uF 10% 10V
C3211	2113743E20	100nF
C3212	2113743E05	18nF
C3213	2311049A40	TANT CP 2.2uF 10% 10V
C3214	2311049A09	TANT CP 2.2uF 10% 20V
C3215	2311049A09	TANT CP 2.2uF 10% 20V
C3221	2113743E20	100nF
C3222	2113743E20	100nF
C3224	0882422W23	FILM SM 1.0uF 15V 5%
C3225	2113743E20	100nF
C3226	2113740F25	8.2pF 5% 50V
C3227	2113740F51	100pF 5% 50V
C3228	2113743E20	100nF
C3229	2113743E12	47nF 10%
C3231	2113741F49	10nF 50V
C3232	2113741F49	10nF 50V
C3233	2311049A40	TANT CP 2.2uF 10% 10V
C3234	2113741F49	10nF 50V
C3235	2113741F49	10nF 50V
C3242	2113740F59	220pF 5% 50V
C3243	2113740F59	220pF 5% 50V
C3244	2113740F59	220pF 5% 50V
C3245	2113740F59	220pF 5% 50V
C3246	2113740F59	220pF 5% 50V
C3251	2113743E20	100nF
C3252	2113741F25	1nF 50V
C3253	2311049A56	TANT CP 4.7uF 20% 10V
C3254	2113743E20	100nF
C3255	2311049A40	TANT CP 2.2uF 10% 10V
C3263	2113743E20	100nF
C3302	2113740F23	6.8pF 5% 50V
C3303	2113741F49	10nF 50V
C3306	2113740F20	5.1pF 5% 50V
C3311	2113743E07	22nF
C3314	2113740F23	6.8pF 5% 50V

Circuit Ref	Motorola Part No.	Description
C3315	2113740F31	15pF 5% 50V
C3316	2113740F15	3.3pF 5% 50V
C3317	2113740F39	33pF 5% 50V
C3318	2113740F21	5.6pF 5% 50V
C3319	2113741F25	1nF 50V
C3324	2113741F49	10nF 50V
C3332	2113743E20	100nF
C3333	2113743E20	100nF
C3334	2113743E07	22nF
C3335	2113741F49	10nF 50V
C3336	2113741F49	10nF 50V
C3337	2113743E20	100nF
C3341	2113741F25	1nF 50V
C3342	2113740L05	3.0pF +-0.1pF
C3344	2113740F09	1.8pF 5% 50V
C3345	2113740L25	20pF +-0.25pF
C3346	2113741F49	10nF 50V
C3347	2113741F49	10nF 50V
C3348	2113741F49	10nF 50V
C3351	2113741F49	10nF 50V
C3352	2113743E07	22nF
C3355	2113741F49	10nF 50V
C3356	2113743E07	22nF
C3357	2113740F24	7.5pF 5% 50V
C3361	2113741F25	1nF 50V
C3362	2113740F21	5.6pF 5% 50V
C3363	2113740F47	68pF 5% 50V
C3364	2113740F33	18pF 5% 50V
C3365	2113741F25	1nF 50V
C3400	2113740F63	330pF 5% 50V
C3401	2113740F63	330pF 5% 50V
C3402	2113743E07	22nF
C3403	2113740F39	33pF 5% 50V
C3404	2113740F39	33pF 5% 50V
C3405	2113740F67	470pF 5% 50V
C3406	2113740F67	470pF 5% 50V
C3410	2113743E07	22nF
C3411	2113743E07	22nF
C3412	2113740F63	330pF 5% 50V
C3414	2113740F63	330pF 5% 50V
C3415	2113743E07	22nF
C3416	2113740F63	330pF 5% 50V
C3417	2113740F43	47pF 5% 50V
C3418	2113740F39	33pF 5% 50V
C3419	2113741F17	470pF 50V
C3420	2113740F51	100pF 5% 50V
C3421	2113741A57	33nF 50V
C3422	2113740A67	330pF 5% 50V
C3423	2311049A08	TANT CP 1uF 10% 35V
C3424	2113740F67	470pF 5% 50V
C3425	2113743E07	22nF

Circuit Ref	Motorola Part No.	Description
C3426	2113740F63	330pF 5% 50V
C3427	2113741F33	2.2nF 50V
C3428	2113741F33	2.2nF 50V
C3431	2111078B34	HQ 47pF 5%
C3433	2111078B36	HQ 56pF 5%
C3434	2113741A45	10nF 50V
C3435	2113740A67	330pF 5% 50V
C3436	2311049A45	TANT CP 10uF 10% 35V
C3437	2113741A57	33nF 50V
C3438	2111078B59	HQ 470pF 5%
C3439	2111078B59	HQ 470pF 5%
C3440	2113741F25	1nF 50V
C3441	2111078B47	HQ 150pF 5%
C3442	2111078B47	HQ 150pF 5%
C3445	2111078B21	HQ 20pF 5%
C3446	2111078B42	HQ 100pF 5%
C3447	2111078B19	HQ 16pF 5%
C3448	2111078B44	HQ 120pF 5%
C3449	2111078B44	HQ 120pF 5%
C3451	2113741F25	1nF 50V
C3452	2113740F29	12pF 5% 50V
C3453	2113740F67	470pF 5% 50V
C3471	2113743E07	22nF
C3472	2111078B53	HQ 270pF 5%
C3473	2111078B53	HQ 270pF 5%
C3474	2113740F59	220pF 5% 50V
C3475	2113740F23	6.8pF 5% 50V
C3491	2111078B18	HQ 15pF 5%
C3492	2111078B38	HQ 68pF 5%
C3493	2111078B09	HQ 6.8pF 5%
C3494	2111078B16	HQ 13pF 5%
C3495	2111078B01	HQ 3.3pF 5%
C3496	2111078B31	HQ 36pF 5%
C3498	2111078B16	HQ 13pF 5%
C3499	2111078B19	HQ 16pF 5%
C3501	2113741F33	2.2nF 50V
C3502	2113741F33	2.2nF 50V
C3503	2113741F33	2.2nF 50V
C3504	2113741F49	10nF 50V
C3505	2311049A07	TANT CP 1uF 10% 16V
C3506	2113741F33	2.2nF 50V
C3507	2113740F51	100pF 5% 50V
C3508	2113740F67	470pF 5% 50V
C3510	2113740F67	470pF 5% 50V
D3000	4813833C02	DUAL SOT MMBD6100
D3001	4805649Q13	VCTR 1SV228 SOT23
D3003	4880154K03	DUAL SCHOTTKY SOT23
D3004	4805649Q13	VCTR 1SV228 SOT23
D3011	4880142L01	PIN
D3031	4886143B01	MIXER DIODE CROSSOVER
D3101	4880154K03	DUAL SCHOTTKY SOT23

Circuit Ref	Motorola Part No.	Description
D3201	4802233J09	TRIPLE SOT143-RH
D3221	4880236E05	CHIP SCHOTTKY
D3341	4805649Q13	VCTR 1SV228 SOT23
D3361	4805649Q13	VCTR 1SV228 SOT23
D3362	4862824C01	VARACTOR CHIP
D3401	4813833C02	DUAL SOT MMBD6100
D3451	4880236E05	CHIP SCHOTTKY
D3471	4802482J02	PIN MA/COM
D3472	4802482J02	PIN MA/COM
FL3101	9180112R16	44.85 MHZ XSTAL FLTR 80dB
FL3102	9180112R16	44.85 MHZ XSTAL FLTR 80dB
FL3111	9180469V03	CER FLTR 6EL 455 KHZ SMD
FL3112	9180469V06	CER FLTR 6EL 455 KHZ SMD
FL3114	9180468V06	CER FLTR 4EL 455 KHZ SMD
FL3115	9180469V04	CER FLTR 6EL 455 KHZ SMD
L3002	2462587T23	COIL CHIP 470nH
L3021	2462587T30	COIL CHIP 1uH
L3031	2462587T20	COIL CHIP 270nH
L3032	2462587T17	COIL CHIP 150nH
L3100	2462587T25	COIL CHIP 620nH
L3101	2462587T25	COIL CHIP 620nH
L3111	2462587T25	COIL CHIP 620nH
L3112	2462587T25	COIL CHIP 620nH
L3201	2462587Q42	IND CHIP 390nH 10%
L3231	2462587Q20	IND CHIP 2.2uH 20%
L3301	2462587N44	CHIP IND 18 NH 5%
L3302	2462587N53	CHIP IND 100 nH 5%
L3317	2462587V28	CHIP IND 33 NH 5%
L3318	2462587V34	IND CHIP 100nH 5%
L3331	2462587V32	CHIP IND 68NH 5%
L3332	2462587V15	IND CHIP 100nH 10%
L3333	2462587Q47	IND CHIP 1uH 10%
L3341	2484562T13	MINISPRING AW IND 8NH2%
L3343	2462587N56	COIL CHIP 180nH 5%
L3344	2462587N68	CHIP IND 1 uH 5%
L3345	2462587N68	CHIP IND 1 uH 5%
L3346	2484562T18	MINI-SPRING AW IND 35.5NH 2%
L3351	2462587N68	CHIP IND 1 uH 5%
L3361	2462587N50	CHIP IND 56 nH 5%
L3362	2462587N51	CHIP IND 68 nH 5%
L3363	2462587N50	CHIP IND 56 nH 5%
L3364	2462587N68	CHIP IND 1 uH 5%
L3401	2460591A01	SQUARE COIL 4.22nH 3T
L3402	2484657R01	Ferrite Bead
L3403	2462587T13	COIL CHIP 68nH
L3411	2462587T13	COIL CHIP 68nH
L3412	2462587X43	IND CHIP LO-PRO 15.0 N
L3413	2460591B04	SQUARE COIL 11.03nH 4T
L3414	2460591A11	SQUARE COIL 7.66nH 3T
L3421	2484657R01	Ferrite Bead

Circuit Ref	Motorola Part No.	Description
L3422	2460591C23	SQUARE COIL 16nH 3T
L3436	2484657R01	Ferrite Bead
L3437	2460592A01	COIL AW 17nH 2T
L3443	2460591X02	COIL SQUARE 25nH
L3471	2462587X69	IND CHIP 1.2uH 5%
L3472	2460592B01	COIL AW 51nH 4T
L3491	2460592B01	COIL AW 51nH 4T
L3492	2460592B01	COIL AW 51nH 4T
L3493	2460592B01	COIL AW 51nH 4T
M3421	2680499Z01	HEAT SPREADER
Q3001	4813827A07	NPN SML SIG MMBR9
Q3002	4813824A17	PNP 40V .2A B=100-
Q3021	4805921T02	DUAL ROHM FMC2 RH
Q3101	4813827A07	NPN SML SIG MMBR9
Q3102	4813827A07	NPN SML SIG MMBR9
Q3151	4880048M01	NPN DIG 47k/47k
Q3152	4880048M01	NPN DIG 47k/47k
Q3221	4880048M01	NPN DIG 47k/47k
Q3301	4813827A07	NPN SML SIG MMBR9
Q3303	4802245J50	DUAL NPN/PNP UMC5N
Q3304	4805218N63	RF TRANS SOT 323 BFQ67W
Q3411	4805921T02	DUAL ROHM FMC2 RH
Q3421	4802245J55	MRF1507
Q3422	4880048M01	NPN DIG 47k/47k
Q3441	4886136B01	LD MOS PWR MRF1565
Q3442	4880048M01	NPN DIG 47k/47k
Q3471	4880048M01	NPN DIG 47k/47k
Q3472	4805128M27	PNP SOT89 BSR33 LH
R3000	0662057A53	1k5 1/16W 5%
R3001	0662057A97	100k 1/16W
R3002	0662057A43	560 1/16W 5%
R3003	0662057A49	1k 1/16W 5%
R3004	0662057A53	1k5 1/16W 5%
R3006	0662057A39	390 1/16W 5%
R3009	0662057A97	100k 1/16W
R3010	0662057A45	680 OHMS 5%
R3011	0662057A65	4k7 1/16W 5%
R3012	0662057A49	1k 1/16W 5%
R3013	0662057A61	3k3 1/16W 5%
R3014	0662057A18	51 1/16W 5%
R3015	0662057A01	10 1/16W 5%
R3016	0662057A01	10 1/16W 5%
R3018	0662057A39	390 1/16W 5%
R3019	0662057A89	47k 1/16W 5%
R3020	0662057B47	0 1/16W
R3021	0662057A43	560 1/16W 5%
R3022	0662057A39	390 1/16W 5%
R3024	0662057A47	820 1/16W 5%
R3031	0662057A18	51 1/16W 5%
R3033	0662057B47	0 1/16W

Circuit Ref	Motorola Part No.	Description
R3101	0662057A75	12k 1/16W 5%
R3102	0662057A01	10 1/16W 5%
R3105	0662057A25	100 1/16W 5%
R3106	0662057A83	27k 1/16W 5%
R3107	0662057A69	6k8 1/16W 5%
R3108	0662057A44	620 OHMS 5%
R3111	0662057A75	12k 1/16W 5%
R3112	0662057A01	10 1/16W 5%
R3115	0662057A39	390 1/16W 5%
R3116	0662057A37	330 1/16W 5%
R3117	0662057A83	27k 1/16W 5%
R3118	0662057A69	6k8 1/16W 5%
R3130	0662057A18	51 1/16W 5%
R3132	0662057A77	15k 1/16W 5%
R3133	0662057A71	8k2 1/16W 5%
R3134	0662057A73	10k 1/16W 5%
R3135	0662057A51	1k2 1/16W 5%
R3144	0662057A58	2k4 1/16W 5%
R3145	0662057A61	3k3 1/16W 5%
R3146	0662057A45	680 OHMS 5%
R3147	0662057A75	12k 1/16W 5%
R3151	0662057A73	10k 1/16W 5%
R3152	0662057A73	10k 1/16W 5%
R3153	0662057A73	10k 1/16W 5%
R3154	0662057A73	10k 1/16W 5%
R3201	0662057A17	47 1/16W 5%
R3203	0662057A17	47 1/16W 5%
R3204	0662057A17	47 1/16W 5%
R3211	0662057B47	0 1/16W
R3221	0662057A39	390 1/16W 5%
R3222	0662057A45	680 OHMS 5%
R3223	0662057A25	100 1/16W 5%
R3224	0662057A89	47k 1/16W 5%
R3225	0662057A89	47k 1/16W 5%
R3241	0662057A25	100 1/16W 5%
R3242	0662057B47	0 1/16W
R3251	0662057B04	180k 1/16W 5%
R3252	0662057B10	330k 1/16W 5%
R3261	0662057B02	150k 1/16W
R3263	0662057A25	100 1/16W 5%
R3301	0662057A22	75 1/16W 5%
R3302	0662057A25	100 1/16W 5%
R3303	0662057A57	2k2 1/16W 5%
R3304	0662057A49	1k 1/16W 5%
R3308	0662057B47	0 1/16W
R3311	0662057A25	100 1/16W 5%
R3316	0662057B47	0 1/16W
R3318	0662057A09	22 1/16W 5%
R3321	0662057A73	10k 1/16W 5%
R3323	0662057A49	1k 1/16W 5%
R3331	0662057A17	47 1/16W 5%

Circuit Ref	Motorola Part No.	Description
R3335	0662057A13	33 1/16W 5%
R3336	0662057A77	15k 1/16W 5%
R3341	0662057A33	220 1/16W 5%
R3342	0662057A15	39 1/16W 5%
R3343	0662057A25	100 1/16W 5%
R3351	0662057A80	20k 1/16W 5%
R3352	0662057A75	12k 1/16W 5%
R3353	0662057A97	100k 1/16W
R3354	0662057B02	150k 1/16W
R3355	0662057A80	20k 1/16W 5%
R3356	0662057A75	12k 1/16W 5%
R3361	0662057A33	220 1/16W 5%
R3362	0662057A17	47 1/16W 5%
R3363	0662057A87	39k 1/16W 5%
R3364	0662057A57	2k2 1/16W 5%
R3400	0662057A41	470 1/16W 5%
R3401	0662057A36	300 1/16W 5%
R3402	0662057A05	15 1/16W 5%
R3403	0662057A36	300 1/16W 5%
R3404	0662057A73	10k 1/16W 5%
R3405	0662057A25	100 1/16W 5%
R3406	0662057A81	22k 1/16W 5%
R3412	0662057A67	5k6 1/16W 5%
R3413	0662057A61	3k3 1/16W 5%
R3414	0683962T51	120 1W 5%
R3415	0662057A25	100 1/16W 5%
R3416	0662057A25	100 1/16W 5%
R3418	0662057A81	22k 1/16W 5%
R3421	0662057A87	39k 1/16W 5%
R3422	0662057A57	2k2 1/16W 5%
R3423	0662057A87	39k 1/16W 5%
R3424	0662057C13	2R7 1/10W 5%
R3425	0662057C13	2R7 1/10W 5%
R3426	0662057C13	2R7 1/10W 5%
R3427	0662057C13	2R7 1/10W 5%
R3428	0662057A58	2k4 1/16W 5%
R3429	0662057A33	220 1/16W 5%
R3431	0680194M18	51 1W 5%
R3432	0680194M18	51 1W 5%
R3433	0662057C13	2R7 1/10W 5%
R3434	0662057C13	2R7 1/10W 5%
R3435	0662057C13	2R7 1/10W 5%
R3441	0662057A87	39k 1/16W 5%
R3442	0662057A57	2k2 1/16W 5%
R3443	0662057A87	39k 1/16W 5%
R3444	0662057C19	4R7 1/10W 5%
R3445	0662057A58	2k4 1/16W 5%
R3446	0662057B47	0 1/16W
R3452	0662057A65	4k7 1/16W 5%
R3454	0662057A73	10k 1/16W 5%
R3455	0662057A97	100k 1/16W

Circuit Ref	Motorola Part No.	Description
R3457	0683962T51	120 1W 5%
R3471	0662057A41	470 1/16W 5%
R3473	0680194M18	51 1W 5%
R3474	0680194M18	51 1W 5%
R3475	0662057A73	10k 1/16W 5%
R3491	0662057A73	10k 1/16W 5%
R3501	0662057A69	6k8 1/16W 5%
R3502	0662057A87	39k 1/16W 5%
R3504	0662057A73	10k 1/16W 5%
R3505	0662057A97	100k 1/16W
R3507	0662057A80	20k 1/16W 5%
R3508	0662057A97	100k 1/16W
R3509	0662057A49	1k 1/16W 5%
T3001	2508396X02	TRANSFORMER
T3002	2508397X02	TRANSFORMER
U3101	5186144B01	FM IF IC SA616
U3111	5113805A86	IC QUAD ANALOG MUX/ DEMUX
U3115	5113805A86	IC QUAD ANALOG MUX/ DEMUX
U3201	5185963A27	IC TESTED AT25016 48 PIN GFP
U3211	5185963A33	VLTG REG LP2951 SO8
U3301	5105750U54	VCO BUFFER PKG DIE
U3401	5105109Z67	LDMOS DRIVER VHF/UHF
U3402	5113818A03	IC HIGH PERFORMANCE SI
U3501	5185765B01	IC POWER CONTROL
U3502	5185963A15	TEMP SENSOR 1M5
Y3101	4880606B09	CRYSTAL 44.395 MHZ
Y3102	9186145B02	44.85 MHZ XSTAL FLTR 60dB
Y3263	4886182B01	VCTCXO 16.8MHz 2ppm TTSO5V
* Y3261	Not Used	16.8MHz 75Z04

* Motorola Depot Servicing only

Reference designators with an asterisk indicate components which are not fieldreplaceable because they need to be calibrated with specialized factory equipment after installation. Radios in which these parts have been replaced in the field will be off frequency at temperature extremes.

3.0 VHF 1-25W PCB 8486172B06 / Schematics

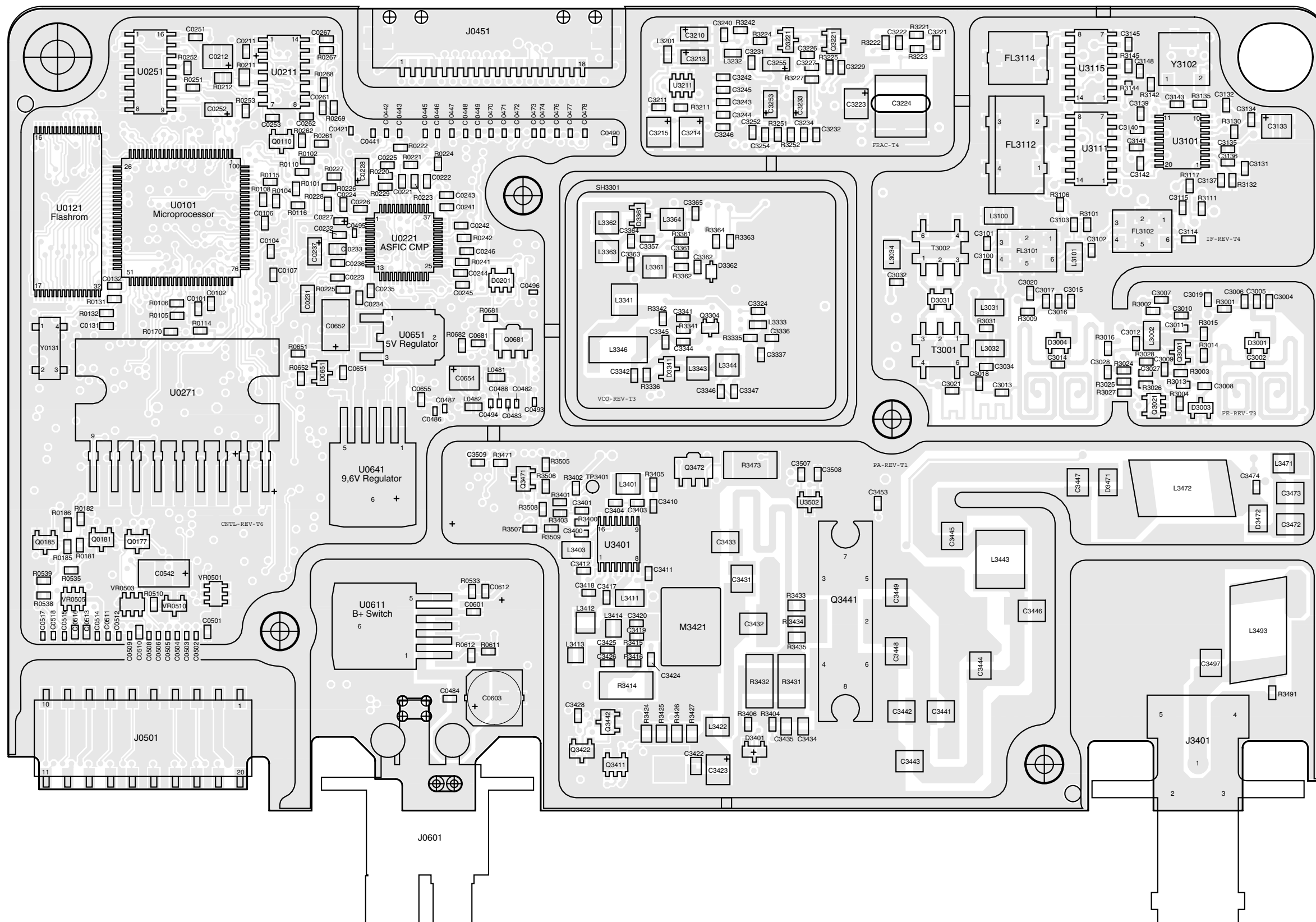

ZWG0130397-O

**VHF (136-174 MHz) 1-25W
8486172B06 Top Side**

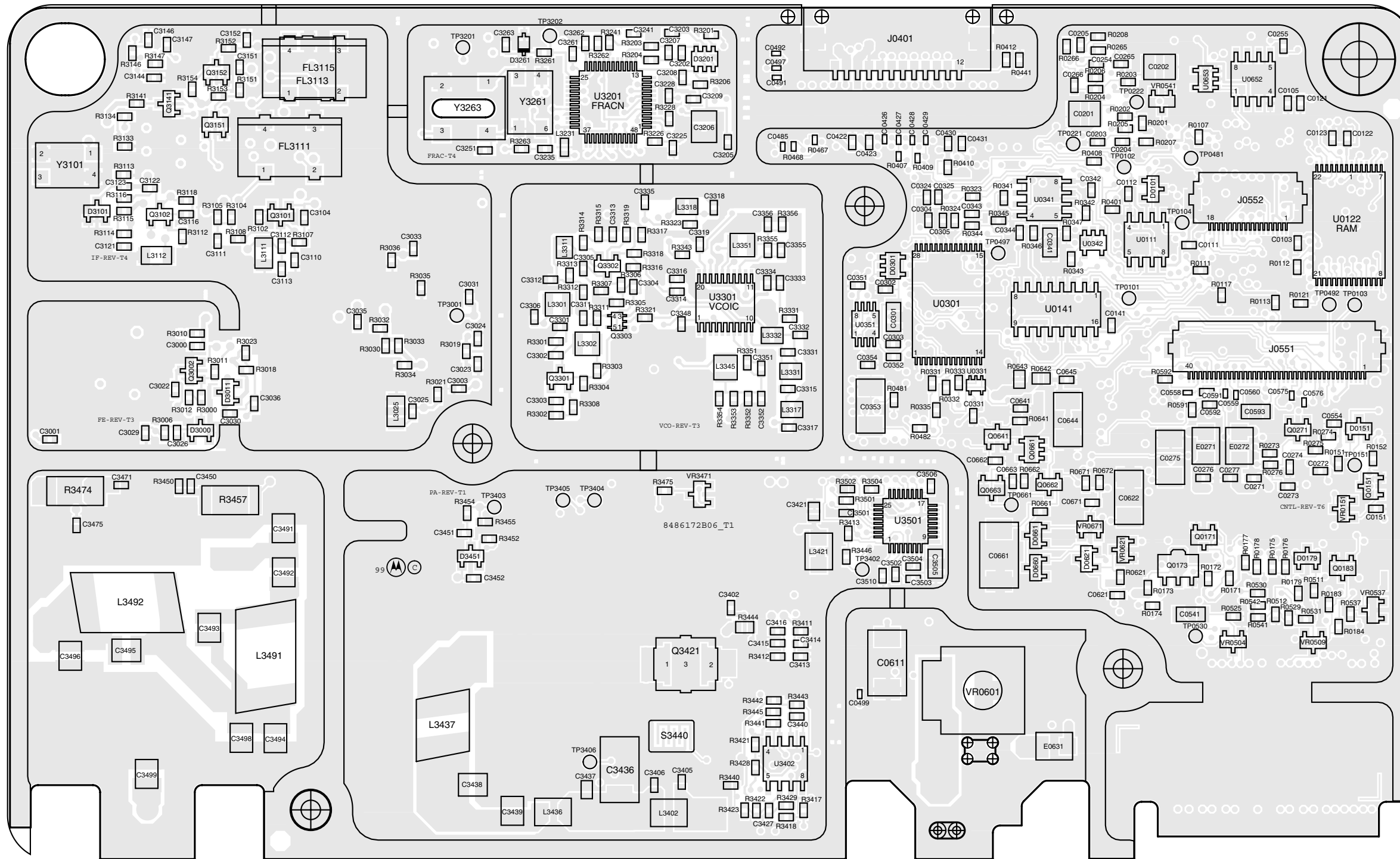

ZWG01300398-O

VHF (136-174 MHz) 1-25W 8486172B06 Bottom Side

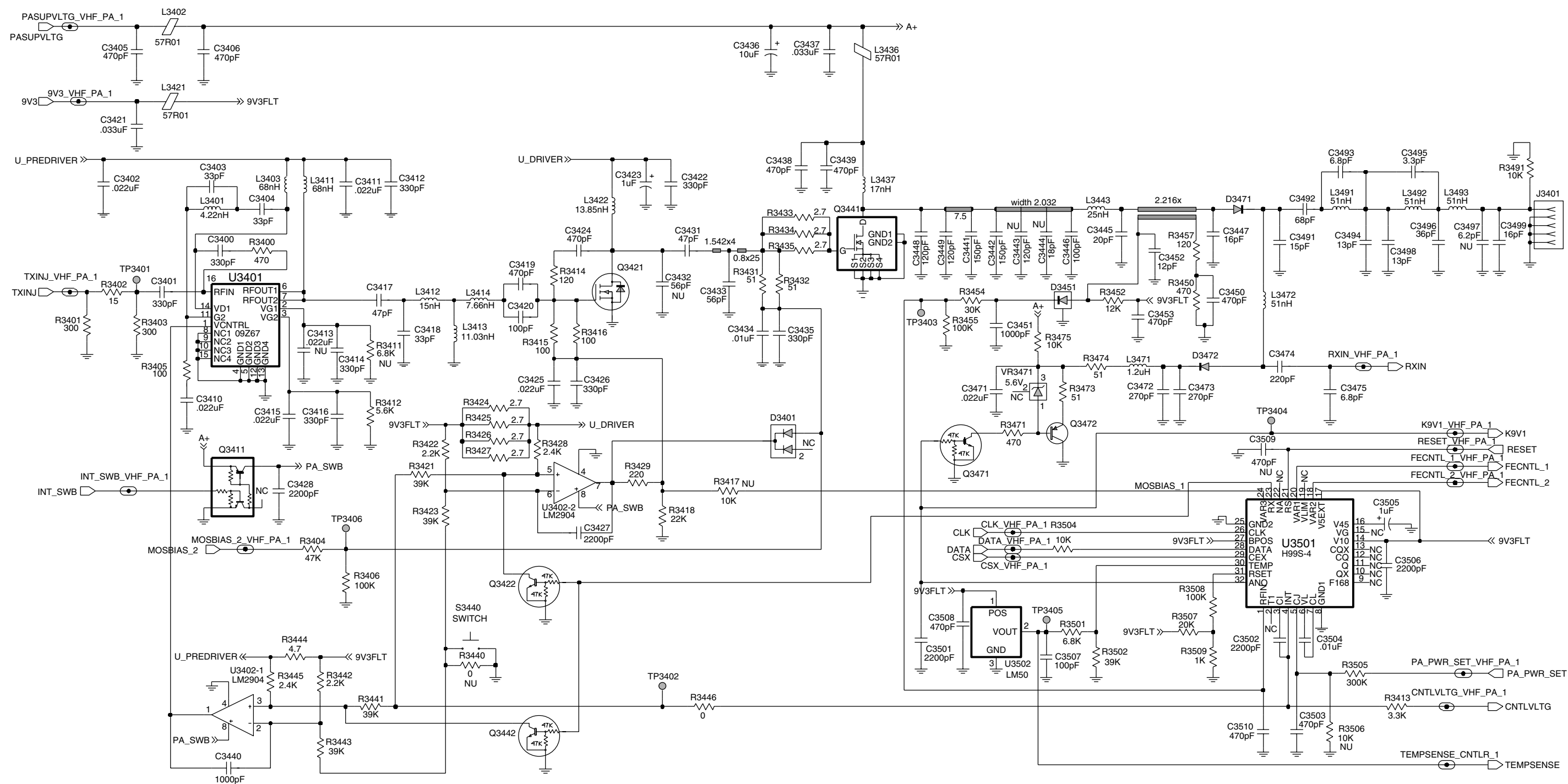

ZWG0130392-A

VHF (136-174 MHz) Power Amplifier 1-25W

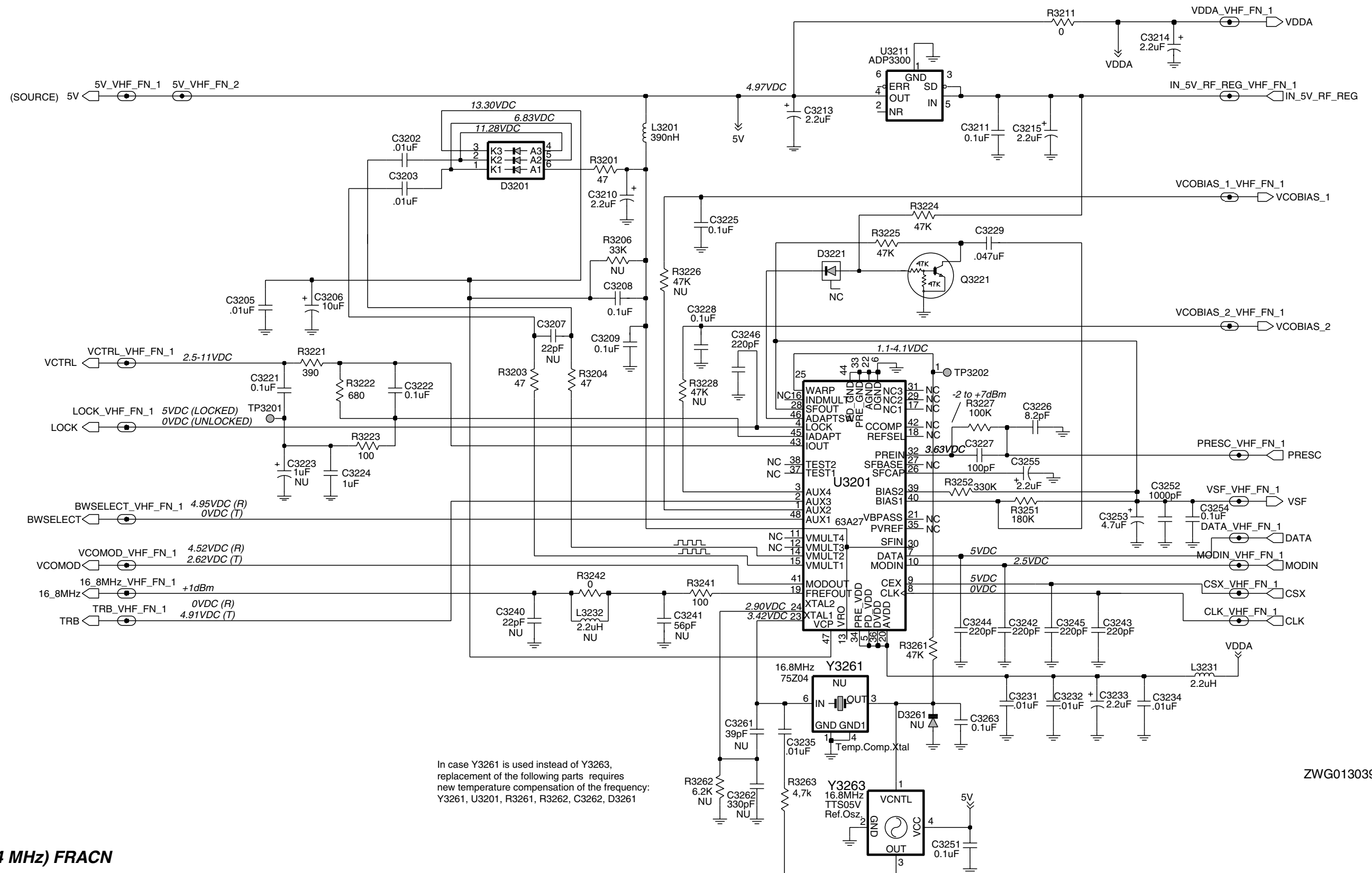

ZWG0130393-A

VHF (136-174 MHz) FRACN

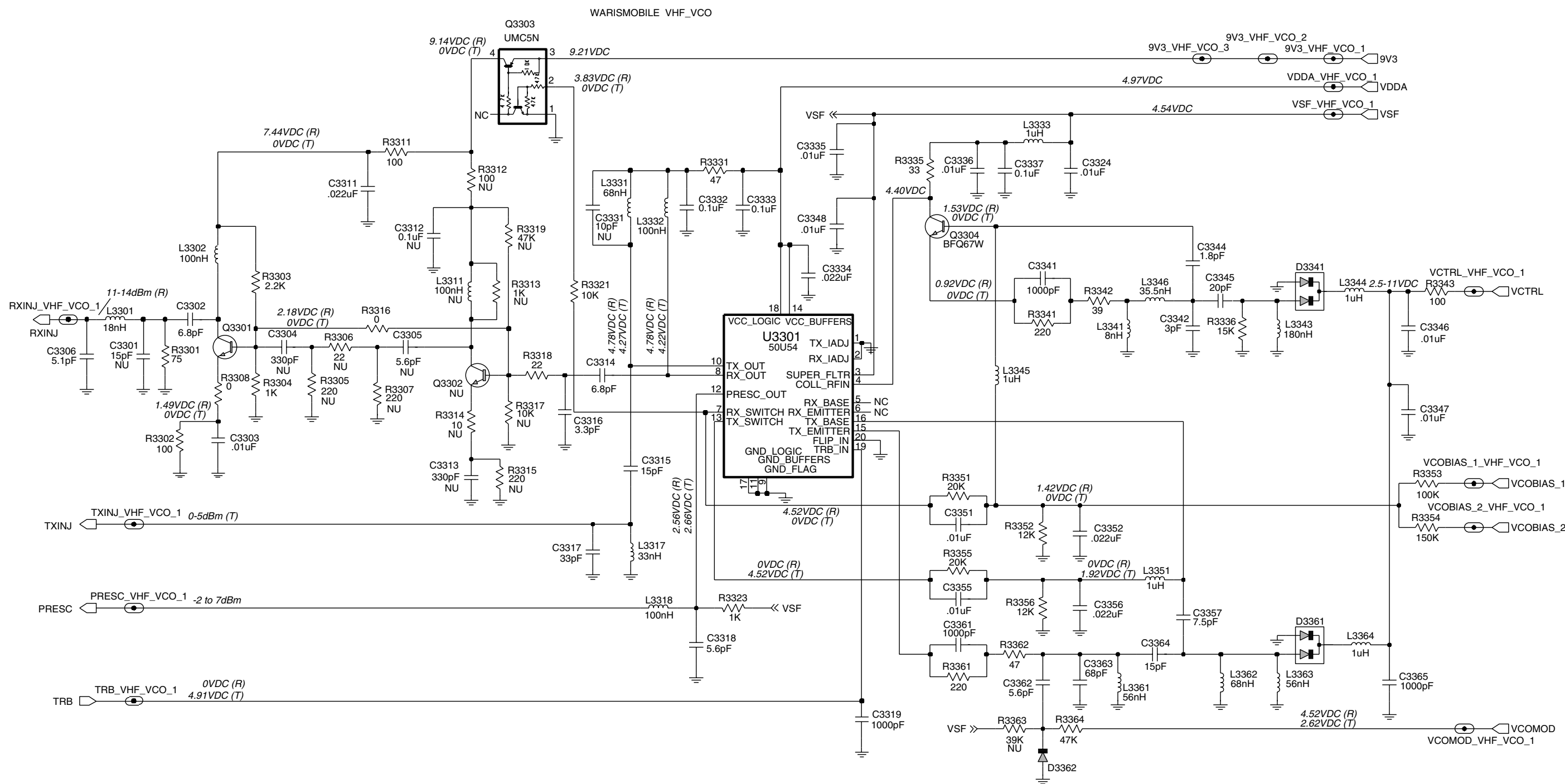

ZWG0130394-O

VHF (136-174 MHz) Voltage Controlled Oscillator

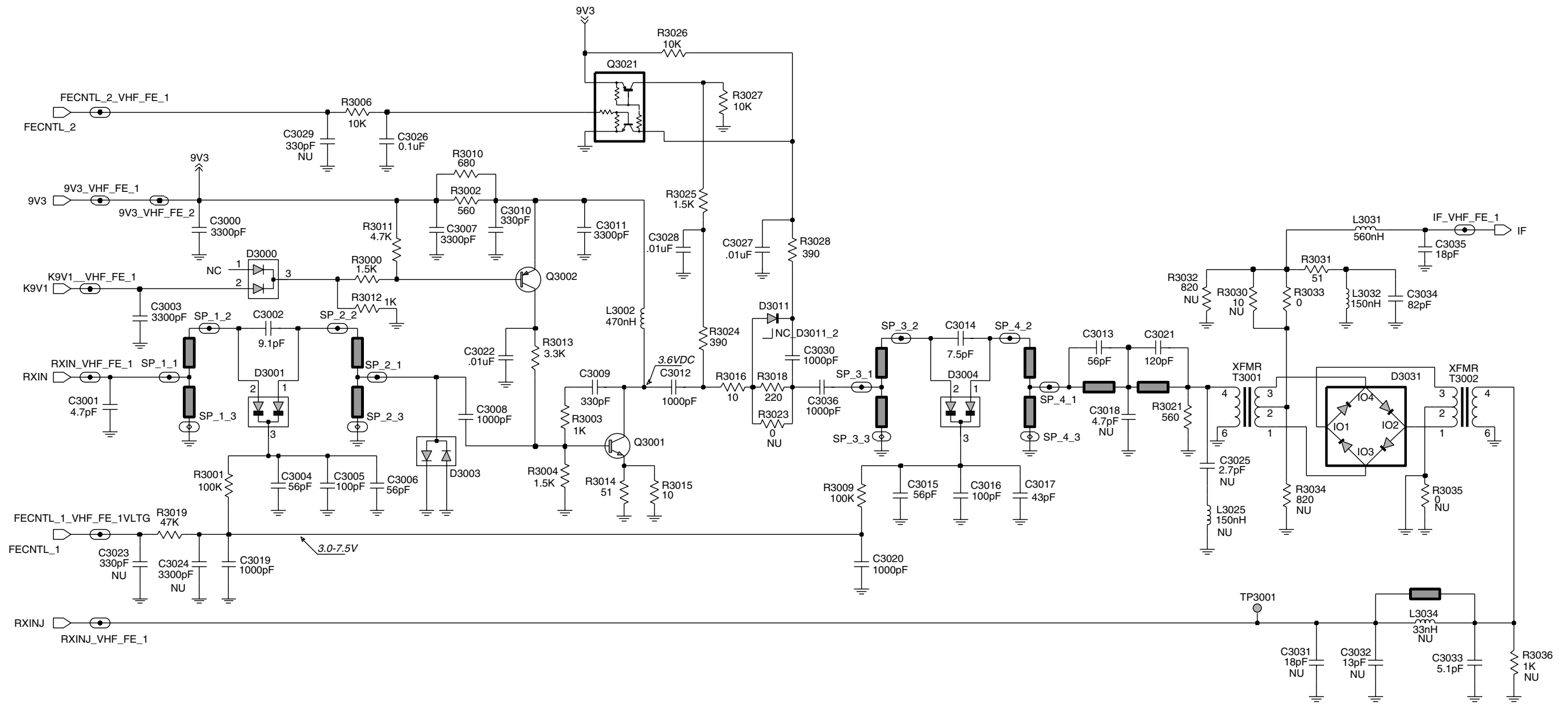

VHF (136-174 MHz) Receiver Front End

ZWG0130395-A

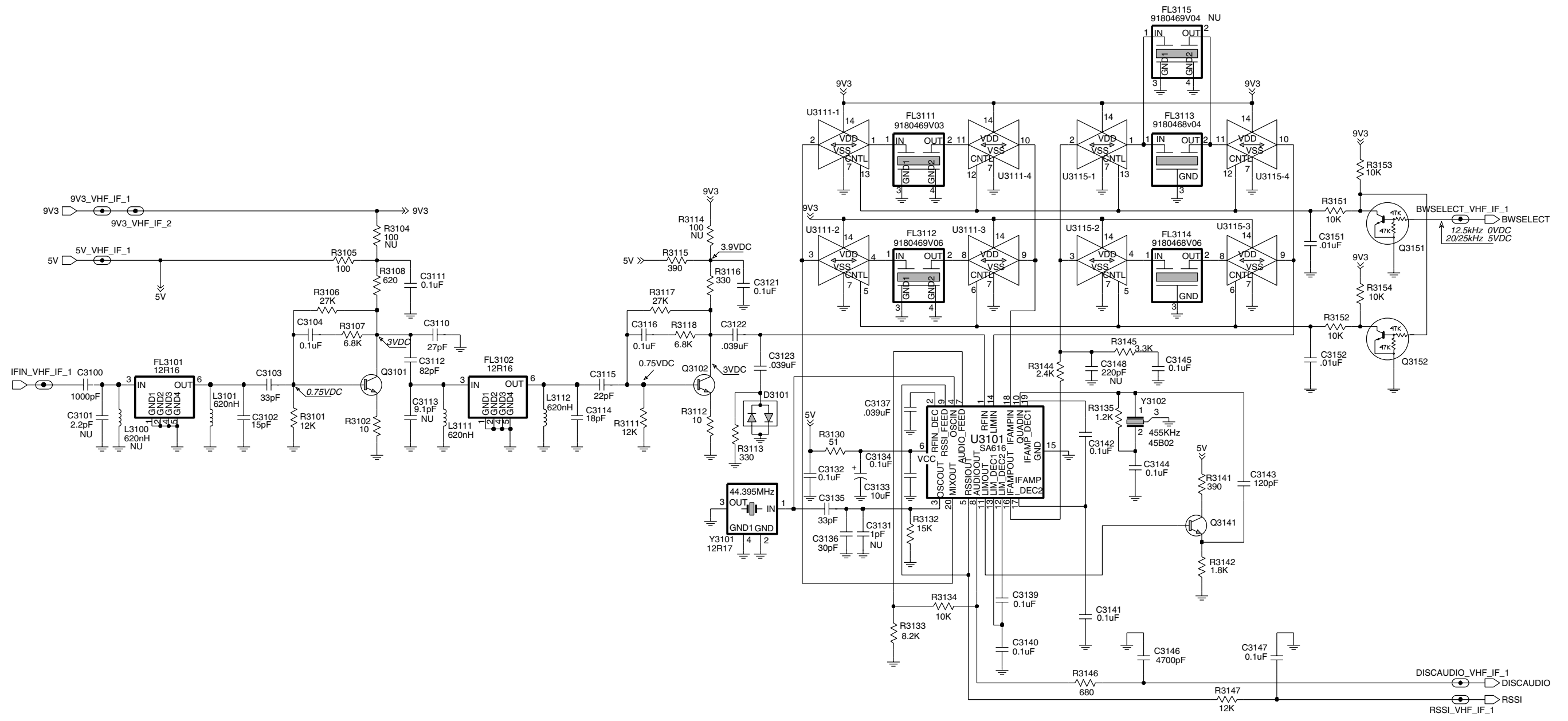

ZWG0130396-O

VHF (136-174 MHz) IF

3.1 VHF PCB 8486172B06 Parts List 1-25W

Circuit Ref	Motorola Part No.	Description
C3000	2113741F37	3.3nF 50V
C3001	2113740F19	4.7pF 5%
C3002	2113740F26	9.1pF 5%
C3003	2113741F37	3.3nF 50V
C3004	2113740F45	56pF 5%
C3005	2113740F51	100pF 5%
C3006	2113740F45	56pF 5%
C3007	2113741F37	3.3nF 50V
C3008	2113741F25	1nF 50V
C3009	2113741F13	330pF 50V
C3010	2113741F13	330pF 50V
C3011	2113741F37	3.3nF 50V
C3012	2113741F25	1nF 50V
C3013	2113740F45	56pF 5%
C3014	2113740F24	7.5pF 5%
C3015	2113740F45	56pF 5%
C3016	2113740F51	100pF 5% 50V
C3017	2113740F42	43pF 5% 50V
C3019	2113741F25	1nF 50V
C3020	2113741F25	1nF 50V
C3021	2113740F53	120pF 5% 50V
C3022	2113741F49	10nF 50V
C3026	2113743E20	100nF 16V
C3027	2113741F49	10nF 50V
C3028	2113741F49	10nF 50V
C3030	2113741F25	1nF 50V
C3033	2113740F20	5.1pF 5% 50V
C3034	2113740F49	82pF 5% 50V
C3035	2113740F33	18pF 5% 50V
C3036	2113741F25	1nF 50V
C3100	2113741F25	1nF 50V
C3102	2113740F31	15pF 5% 50V
C3103	2113740F39	33pF 5% 50V
C3104	2113743E20	100nF 16V
C3110	2113740F37	27pF 5% 50V
C3111	2113743E20	100nF 16V
C3112	2113740F49	82pF 5% 50V
C3114	2113740F33	18pF 5% 50V
C3115	2113740F35	22pF 5% 50V
C3116	2113743E20	100nF 16V
C3121	2113743E20	100nF 16V
C3122	2113743E11	39nF 10%
C3123	2113743E11	39nF 10%
C3132	2113743E20	100nF 16V
C3133	2311049A57	TANT CP 10uF 10% 16V
C3134	2113743E20	100nF 16V
C3135	2113740L30	33pF 2%
C3136	2113740L29	30pF 2%
C3137	2113743E11	39nF 10%
C3139	2113743E20	100nF 16V

Circuit Ref	Motorola Part No.	Description
C3140	2113743E20	100nF 16V
C3141	2113743E20	100nF 16V
C3142	2113743E20	100nF 16V
C3143	2113740F53	120pF 5% 50V
C3144	2113743E20	100nF 16V
C3145	2113743E20	100nF 16V
C3146	2113741F41	4.7nF 50V
C3147	2113743E20	100nF 16V
C3151	2113741F49	10nF 50V
C3152	2113741F49	10nF 50V
C3202	2113741F49	10nF 50V
C3203	2113741F49	10nF 50V
C3205	2113741F49	10nF 50V
C3206	2311049A57	TANT CP 10uF 10% 16V
C3208	2113743E20	100nF 16V
C3209	2113743E20	100nF 16V
C3210	2311049A40	TANT CP 2.2uF 10% 10V
C3211	2113743E20	100nF 16V
C3213	2311049A40	TANT CP 2.2uF 10% 10V
C3214	2311049A09	TANT CP 2.2uF 10% 20V
C3215	2311049A09	TANT CP 2.2uF 10% 20V
C3221	2113743E20	100nF 16V
C3222	2113743E20	100nF 16V
C3224	0882422W23	FILM SM 1.0uF 15V 5%
C3225	2113743E20	100nF 16V
C3226	2113740F25	8.2pF 5% 50V
C3227	2113740F51	100pF 5% 50V
C3228	2113743E20	100nF 16V
C3229	2113743E12	47nF 10%
C3231	2113741F49	10nF 50V
C3232	2113741F49	10nF 50V
C3233	2311049A40	TANT CP 2.2uF 10%
C3234	2113741F49	10nF 50V
C3235	2113741F49	10nF 50V
C3242	2113740F59	220pF 5% 50V
C3243	2113740F59	220pF 5% 50V
C3244	2113740F59	220pF 5% 50V
C3245	2113740F59	220pF 5% 50V
C3246	2113740F59	220pF 5% 50V
C3251	2113743E20	100nF 16V
C3252	2113741F25	1nF 50V
C3253	2311049A56	TANT CP 4.7uF 20% 10V
C3254	2113743E20	100nF 16V
C3255	2311049A40	TANT CP 2.2uF 10% 10V
C3263	2113743E20	100nF 16V
C3302	2113740F23	6.8pF 5% 50V
C3303	2113741F49	10nF 50V
C3306	2113740F20	5.1pF 5% 50V
C3311	2113743E07	22nF 16V
C3314	2113740F23	6.8pF 5% 50V
C3315	2113740F31	15pF 5% 50V

Circuit Ref	Motorola Part No.	Description
C3316	2113740F15	3.3pF 5% 50V
C3317	2113740F39	33pF 5% 50V
C3318	2113740F21	5.6pF 5% 50V
C3319	2113741F25	1nF 50V
C3324	2113741F49	10nF 50V
C3332	2113743E20	100nF 16V
C3333	2113743E20	100nF 16V
C3334	2113743E07	22nF 16V
C3335	2113741F49	10nF 50V
C3336	2113741F49	10nF 50V
C3337	2113743E20	100nF 16V
C3341	2113741F25	1nF 50V
C3342	2113740L05	3.0pF +-0.1pF
C3344	2113740F09	1.8pF 5% 50V
C3345	2113740L25	20pF +-0.25pF
C3346	2113741F49	10nF 50V
C3347	2113741F49	10nF 50V
C3348	2113741F49	10nF 50V
C3351	2113741F49	10nF 50V
C3352	2113743E07	22nF 16V
C3355	2113741F49	10nF 50V
C3356	2113743E07	22nF 16V
C3357	2113740F24	7.5pF 5% 50V
C3361	2113741F25	1nF 50V
C3362	2113740F21	5.6pF 5% 50V
C3363	2113740F47	68pF 5% 50V
C3364	2113740F31	15pF 5% 50V
C3365	2113741F25	1nF 50V
C3400	2113740F63	330pF 5% 50V
C3401	2113740F63	330pF 5% 50V
C3402	2113743E07	22nF 16V
C3403	2113740F39	33pF 5% 50V
C3404	2113740F39	33pF 5% 50V
C3405	2113740F67	470pF 5% 50V
C3406	2113740F67	470pF 5% 50V
C3410	2113743E07	22nF 16V
C3411	2113743E07	22nF 16V
C3412	2113740F63	330pF 5% 50V
C3414	2113740F63	330pF 5% 50V
C3415	2113743E07	22nF 16V
C3416	2113740F63	330pF 5% 50V
C3417	2113740F43	47pF 5% 50V
C3418	2113740F39	33pF 5% 50V
C3419	2113740F57	180pF 5% 50V
C3420	2113740F57	180pF 5% 50V
C3421	2113741A57	33nF 50V
C3422	2113740A67	330pF 5% 50V
C3423	2311049A08	TANT CP 1uF 10% 35V
C3424	2113740F67	470pF 5% 50V
C3425	2113743E07	22nF 16V
C3426	2113740F63	330pF 5% 50V

Circuit Ref	Motorola Part No.	Description
C3427	2113741F33	2.2nF 50V
C3428	2113741F33	2.2nF 50V
C3431	2111078B34	HQ 47pF 5%
C3433	2111078B36	HQ 56pF 5%
C3434	2113741A45	10nF 50V
C3435	2113740A67	330pF 5% 50V
C3436	2311049A45	TANT CP 10uF 10% 35V
C3437	2113741A57	33nF 50V
C3438	2111078B59	HQ 470pF 5%
C3439	2111078B59	HQ 470pF 5%
C3440	2113741F25	1nF 50V
C3441	2111078B47	HQ 150pF 5%
C3442	2111078B47	HQ 150pF 5%
C3445	2111078B21	HQ 20pF 5%
C3446	2111078B42	HQ 100pF 5%
C3447	2111078B19	HQ 16pF 5%
C3448	2111078B44	HQ 120pF 5%
C3449	2111078B44	HQ 120pF 5%
C3450	2113740F67	470pF 5% 50V
C3451	2113741F25	1nF 50V
C3452	2113740F29	12pF 5% 50V
C3453	2113740F67	470pF 5% 50V
C3471	2113743E07	22nF 16V
C3472	2111078B53	HQ 270pF 5%
C3473	2111078B53	HQ 270pF 5%
C3474	2113740F59	220pF 5% 50V
C3475	2113740F23	6.8pF 5% 50V
C3491	2111078B18	HQ 15pF 5%
C3492	2111078B38	HQ 68pF 5%
C3493	2111078B09	HQ 6.8pF 5%
C3494	2111078B16	HQ 13pF 5%
C3495	2111078B01	HQ 3.3pF 5%
C3496	2111078B31	HQ 36pF 5%
C3498	2111078B16	HQ 13pF 5%
C3499	2111078B19	HQ 16pF 5%
C3501	2113741F33	2.2nF 50V
C3502	2113741F33	2.2nF 50V
C3503	2113740F67	470pF 5% 50V
C3504	2113741F49	10nF 50V
C3505	2311049A07	TANT CP 1uF 10% 16V
C3506	2113741F33	2.2nF 50V X7R
C3507	2113740F51	100pF 5% 50V
C3508	2113740F67	470pF 5% 50V
C3510	2113740F67	470pF 5% 50V
D3000	4813833C02	DUAL SOT MMBD6100
D3001	4805649Q13	VCTR 1SV228 SOT23
D3003	4880154K03	DUAL SCHOTTKY SOT23
D3004	4805649Q13	VCTR 1SV228 SOT23
D3011	4880142L01	PIN
D3031	4886143B01	MIXER DIODE CROSSOVER
D3101	4880154K03	DIODE DUAL SCHOTTKY

Circuit Ref	Motorola Part No.	Description
D3201	4802233J09	TRIPLE SOT143-RH
D3221	4880236E05	CHIP SCHOTTKY
D3341	4805649Q13	VCTR 1SV228 SOT23
D3361	4805649Q13	VCTR 1SV228 SOT23
D3362	4862824C01	VARACTOR CHIP
D3401	4813833C02	DUAL SOT MMBD6100
D3451	4880236E05	CHIP SCHOTTKY
D3471	4802482J02	PIN MA/COM
D3472	4802482J02	PIN MA/COM
FL3101	9180112R16	44.85 MHZ XTAL FLTR 80dB
FL3102	9180112R16	44.85 MHZ XTAL FLTR 80dB
FL3111	9180469V03	CER FLTR 6EL 455 KHZ SMD
FL3112	9180469V06	CER FLTR 6EL 455 KHZ SMD
FL3113	9180468V04	CER FLTR 4EL 455 KHZ SMD
FL3114	9180468V06	CER FLTR 4EL 455 KHZ SMD
J3401	0986166B02	RF CONN MINI UHF
L3002	2462587T23	COIL CHIP 470nH
L3031	2462587T24	COIL CHIP 560nH
L3032	2462587T17	COIL CHIP 150nH
L3101	2462587T25	COIL CHIP 620nH
L3111	2462587T25	COIL CHIP 620nH
L3112	2462587T25	COIL CHIP 620nH
L3201	2462587Q42	IND CHIP 390nH 10%
L3231	2462587Q20	IND CHIP 2.2uH 20%
L3301	2462587N44	CHIP IND 18 nH 5%
L3302	2462587N53	CHIP IND 100 nH 5%
L3317	2462587V28	CHIP IND 33 NH 5%
L3318	2462587V34	IND CHIP 100nH 5%
L3331	2462587V32	CHIP IND 68NH 5%
L3332	2462587V15	IND CHIP 100nH 10%
L3333	2462587Q47	IND CHIP 1uH 10%
L3341	2484562T13	MINI-SPRING AW IND 8NH 2%
L3343	2462587N56	COIL CHIP 180nH 5%
L3344	2462587N68	CHIP IND 1 uH 5%
L3345	2462587N68	CHIP IND 1 uH 5%
L3346	2484562T18	MINI-SPRING AW IND 35.5NH 2%
L3351	2462587N68	CHIP IND 1 uH 5%
L3361	2462587N50	CHIP IND 56 nH 5%
L3362	2462587N51	CHIP IND 68 nH 5%
L3363	2462587N50	CHIP IND 56 nH 5%
L3364	2462587N68	CHIP IND 1 uH 5%
L3401	2460591A01	SQUARE COIL 4.22nH 3T
L3402	2484657R01	Ferrite Bead
L3403	2462587T13	COIL CHIP 68nH
L3411	2462587T13	COIL CHIP 68nH
L3412	2462587X43	IND CHIP LO-PRO 15.0
L3413	2460591B04	SQUARE COIL 11.03nH 4T
L3414	2460591A11	SQUARE COIL 7.66nH 3T
L3421	2484657R01	Ferrite Bead

Circuit Ref	Motorola Part No.	Description
L3422	2460591C23	SQUARE COIL 16nH 3T
L3436	2484657R01	Ferrite Bead
L3437	2460592A01	COIL AW 17nH 2T
L3443	2460591X02	COIL SQUARE 25nH
L3471	2462587X69	IND CHIP 1.2uH 5%
L3472	2460592B01	COIL AW 51nH 4T
L3491	2460592B01	COIL AW 51nH 4T
L3492	2460592B01	COIL AW 51nH 4T
L3493	2460592B01	COIL AW 51nH 4T
M3421	2686201B01	HEAT SPREADER
Q3001	4813827A07	TSTR NPN SML SIG MMBR9
Q3002	4813824A17	TSTR PNP 40V .2A B=100-
Q3021	4805921T02	TSTR DUAL ROHM FMC2
Q3101	4813827A07	TSTR NPN SML SIG MMBR9
Q3102	4813827A07	TSTR NPN SML SIG MMBR9
Q3141	4813824A10	TSTR NPN 40V .2A B=50-150
Q3151	4880048M01	TSTR NPN DIG 47k/47k
Q3152	4880048M01	TSTR NPN DIG 47k/47k
Q3221	4880048M01	TSTR NPN DIG 47k/47k
Q3301	4813827A07	TSTR NPN SML SIG MMBR9
Q3303	4802245J50	TSTR DUAL NPN/PNP UMC5N
Q3304	4805218N63	RF TRANS SOT 323 BFQ67W
Q3411	4805921T02	DUAL ROHM FMC2 RH
Q3421	4802245J55	MRF1507
Q3422	4880048M01	NPN DIG 47k/47k
Q3441	4886136B01	LD MOS PWR TSTR MRF1565 MRF1550
Q3442	4880048M01	NPN DIG 47k/47k
Q3471	4880048M01	NPN DIG 47k/47k
Q3472	4805128M27	PNP SOT89 BSR33 LH
R3000	0662057A53	1k5 1/16W 5%
R3001	0662057A97	100k 1/16W
R3002	0662057A43	560 1/16W 5%
R3003	0662057A49	1k 1/16W 5%
R3004	0662057A53	1k5 1/16W 5%
R3006	0662057A73	10k 1/16W 5%
R3009	0662057A97	100k 1/16W
R3010	0662057A45	680 OHMS 5%
R3011	0662057A65	4k7 1/16W 5%
R3012	0662057A49	1k 1/16W 5%
R3013	0662057A61	3k3 1/16W 5%
R3014	0662057A18	51 1/16W 5%
R3015	0662057A01	10 1/16W 5%
R3016	0662057A01	10 1/16W 5%
R3018	0662057A33	220 1/16W 5%
R3019	0662057A89	47k 1/16W 5%
R3021	0662057A43	560 1/16W 5%
R3024	0662057A39	390 1/16W 5%
R3025	0662057A53	1k5 1/16W 5%

Circuit Ref	Motorola Part No.	Description
R3026	0662057A73	10k 1/16W 5%
R3027	0662057A73	10k 1/16W 5%
R3028	0662057A39	390 1/16W 5%
R3031	0662057A18	51 1/16W 5%
R3033	0662057B47	0 1/16W
R3101	0662057A75	12k 1/16W 5%
R3102	0662057A01	10 1/16W 5%
R3105	0662057A25	100 1/16W 5%
R3106	0662057A83	27k 1/16W 5%
R3107	0662057A69	6k8 1/16W 5%
R3108	0662057A44	620 OHMS 5%
R3111	0662057A75	12k 1/16W 5%
R3112	0662057A01	10 1/16W 5%
R3113	0662057A37	330 1/16W 5%
R3115	0662057A39	390 1/16W 5%
R3116	0662057A37	330 1/16W 5%
R3117	0662057A83	27k 1/16W 5%
R3118	0662057A69	6k8 1/16W 5%
R3130	0662057A18	51 1/16W 5%
R3132	0662057A77	15k 1/16W 5%
R3133	0662057A71	8k2 1/16W 5%
R3134	0662057A73	10k 1/16W 5%
R3135	0662057A51	1k2 1/16W 5%
R3141	0662057A39	390 1/16W 5%
R3142	0662057A55	1k8 1/16W 5%
R3144	0662057A58	2k4 1/16W 5%
R3145	0662057A61	3k3 1/16W 5%
R3146	0662057A45	680 OHMS 5%
R3147	0662057A75	12k 1/16W 5%
R3151	0662057A73	10k 1/16W 5%
R3152	0662057A73	10k 1/16W 5%
R3153	0662057A73	10k 1/16W 5%
R3154	0662057A73	10k 1/16W 5%
R3201	0662057A17	47 1/16W 5%
R3203	0662057A17	47 1/16W 5%
R3204	0662057A17	47 1/16W 5%
R3211	0662057B47	0 1/16W
R3221	0662057A39	390 1/16W 5%
R3222	0662057A45	CHIP RES 680 OHMS 5%
R3223	0662057A25	100 1/16W 5%
R3224	0662057A89	47k 1/16W 5%
R3225	0662057A89	47k 1/16W 5%
R3227	0662057A97	100k 1/16W
R3241	0662057A25	100 1/16W 5%
R3242	0662057B47	0 1/16W
R3251	0662057B04	180k 1/16W 5%
R3252	0662057B10	330k 1/16W 5%
R3261	0662057A89	47k 1/16W 5%
R3263	0662057A65	4k7 1/16W 5%
R3301	0662057A22	75 1/16W 5%
R3302	0662057A25	100 1/16W 5%

Circuit Ref	Motorola Part No.	Description
R3303	0662057A57	2k2 1/16W 5%
R3304	0662057A49	1k 1/16W 5%
R3308	0662057B47	0 1/16W
R3311	0662057A25	100 1/16W 5%
R3316	0662057B47	0 1/16W
R3318	0662057A09	22 1/16W 5%
R3321	0662057A73	10k 1/16W 5%
R3323	0662057A49	1k 1/16W 5%
R3331	0662057A17	47 1/16W 5%
R3335	0662057A13	33 1/16W 5%
R3336	0662057A77	15k 1/16W 5%
R3341	0662057A33	220 1/16W 5%
R3342	0662057A15	39 1/16W 5%
R3343	0662057A25	100 1/16W 5%
R3351	0662057A80	20k 1/16W 5%
R3352	0662057A75	12k 1/16W 5%
R3353	0662057A97	100k 1/16W
R3354	0662057B02	150k 1/16W
R3355	0662057A80	20k 1/16W 5%
R3356	0662057A75	12k 1/16W 5%
R3361	0662057A33	220 1/16W 5%
R3362	0662057A17	47 1/16W 5%
R3364	0662057A89	47k 1/16W 5%
R3400	0662057A41	470 1/16W 5%
R3401	0662057A36	300 1/16W 5%
R3402	0662057A05	15 1/16W 5%
R3403	0662057A36	300 1/16W 5%
R3404	0662057A89	47k 1/16W 5%
R3405	0662057A25	100 1/16W 5%
R3406	0662057A97	100k 1/16W
R3412	0662057A67	5k6 1/16W 5%
R3413	0662057A61	3k3 1/16W 5%
R3414	0683962T51	120 1W 5%
R3415	0662057A25	100 1/16W 5%
R3416	0662057A25	100 1/16W 5%
R3418	0662057A81	22k 1/16W 5%
R3421	0662057A87	39k 1/16W 5%
R3422	0662057A57	2k2 1/16W 5%
R3423	0662057A87	39k 1/16W 5%
R3424	0662057C13	2R7 1/10W 5%
R3425	0662057C13	2R7 1/10W 5%
R3426	0662057C13	2R7 1/10W 5%
R3427	0662057C13	2R7 1/10W 5%
R3428	0662057A58	2k4 1/16W 5%
R3429	0662057A33	220 1/16W 5%
R3431	0680194M18	51 1W 5%
R3432	0680194M18	51 1W 5%
R3433	0662057C13	2R7 1/10W 5%
R3434	0662057C13	2R7 1/10W 5%
R3435	0662057C13	2R7 1/10W 5%
R3441	0662057A87	39k 1/16W 5%

Circuit Ref	Motorola Part No.	Description
R3442	0662057A57	2k2 1/16W 5%
R3443	0662057A87	39k 1/16W 5%
R3444	0662057C19	4R7 1/10W 5%
R3445	0662057A58	2k4 1/16W 5%
R3446	0662057B47	0 1/16W
R3450	0662057A41	470 1/16W 5%
R3452	0662057A75	12k 1/16W 5%
R3454	0662057A84	30k 1/16W 5%
R3455	0662057A97	100k 1/16W
R3457	0683962T51	120 1W 5%
R3471	0662057A41	470 1/16W 5%
R3473	0680194M18	51 1W 5%
R3474	0680194M18	51 1W 5%
R3475	0662057A73	10k 1/16W 5%
R3491	0662057A73	10k 1/16W 5%
R3501	0662057A69	6k8 1/16W 5%
R3502	0662057A87	39k 1/16W 5%
R3504	0662057A73	10k 1/16W 5%
R3505	0662057B09	300k 1/16W 5%
R3507	0662057A80	20k 1/16W 5%
R3508	0662057A97	100k 1/16W
R3509	0662057A49	1k 1/16W 5%
T3001	2508396X02	TRANSFORMER
T3002	2508397X02	TRANSFORMER
U3101	5186144B01	FM IF IC SA616
U3111	5113805A86	IC QUAD ANALOG MUX/ DEMUX
U3115	5113805A86	IC QUAD ANALOG MUX/ DEMUX
U3201	5185963A27	IC TESTED AT25016 48PIN GFP
U3211	5105739X05	IC SOT 5V HI-PRECISION REGULAT
U3301	5105750U54	VCO BUFFER PKG DIE
U3401	5105109Z67	LDMOS DRIVER VHF/UHF
U3402	5180932W01	LINEAR IC OP AMP
U3501	5185765B01	IC POWER CONTROL
U3502	5185963A15	TEMP SENSOR 1M5
VR3471	4813830A15	5.6V 5% 225mW
Y3101	4880606B09	CRYSTAL 44.395 MHZ
Y3102	9186145B02	CERAMIC DISCRIMINATOR 455kHz
Y3263	4886182B01	VCTCXO 16.8MHz 2ppm TTSO5V
* Y3261	Not Used	16.8MHz 75Z04

* Motorola Depot Servicing only

Reference designators with an asterisk indicate components which are not fieldreplaceable because they need to be calibrated with specialized factory equipment after installation. Radios in which these parts have been replaced in the field will be off frequency at temperature extremes.

4.0 VHF 1-25W PCB 8486172B07 / Schematics

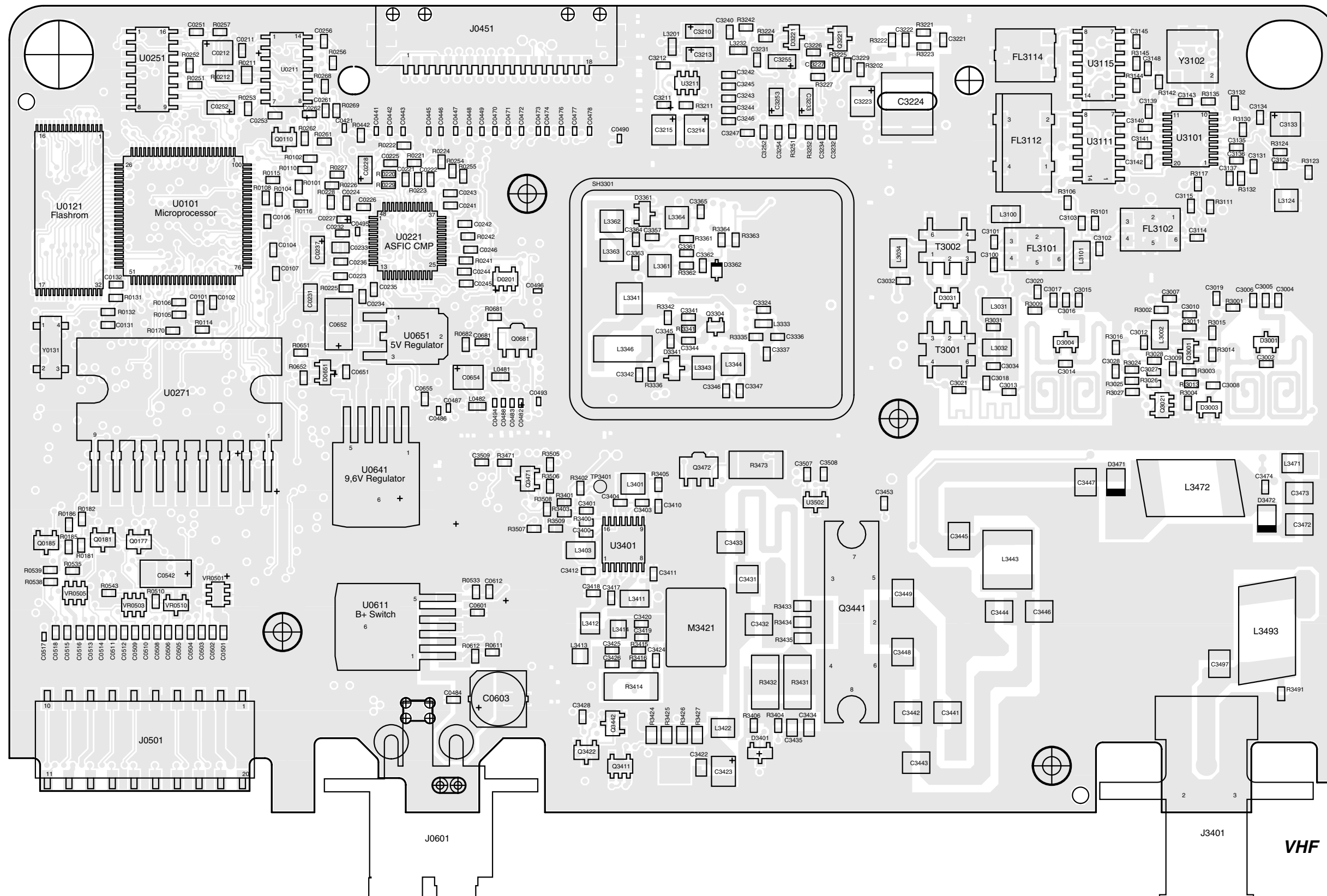

ZWG0130397-A

VHF (136-174 MHz) 1-25W
846172B07 Top Side

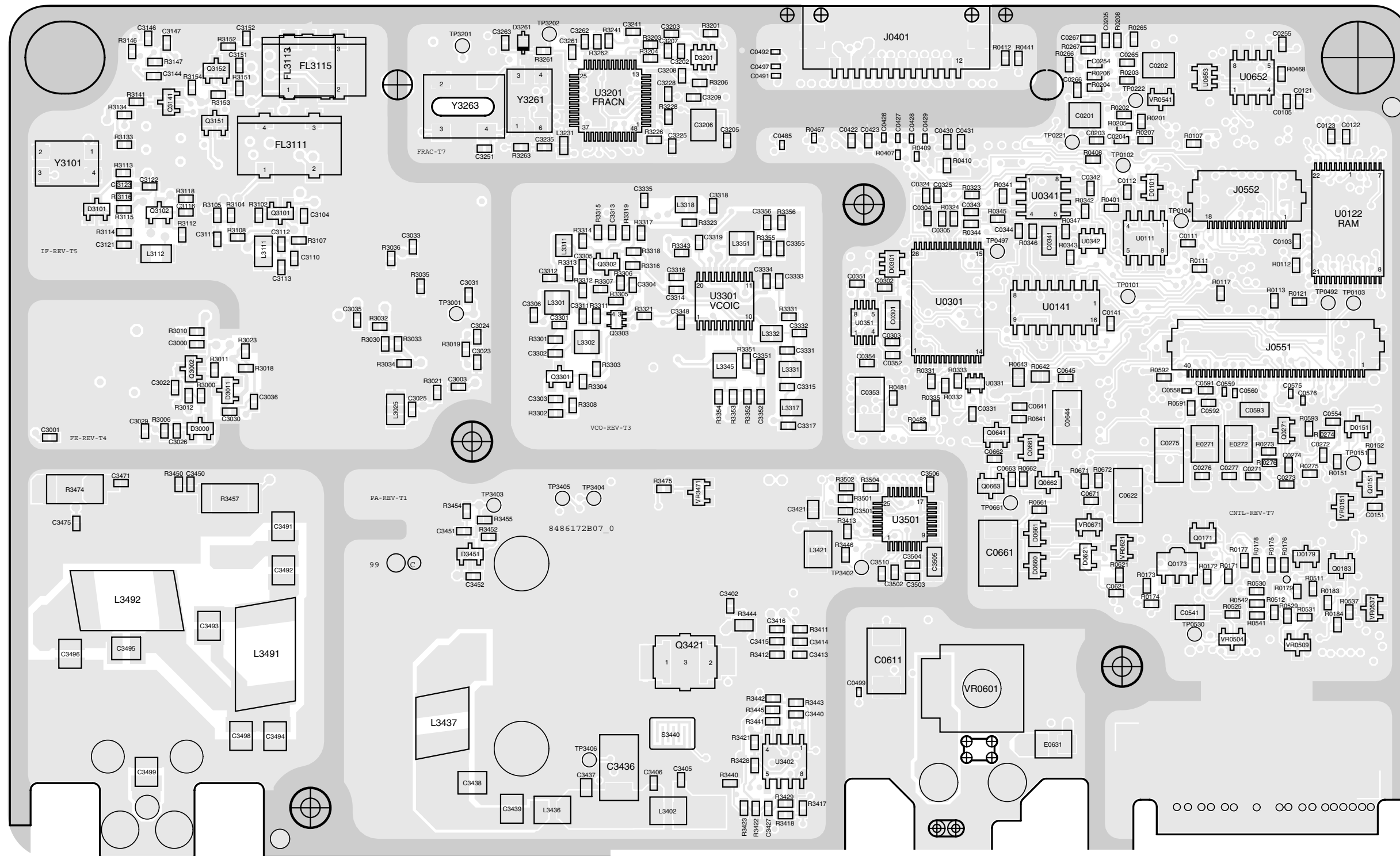

ZWG01300398-A

VHF (136-174 MHz) 1-25W 8486172B07 Bottom Side

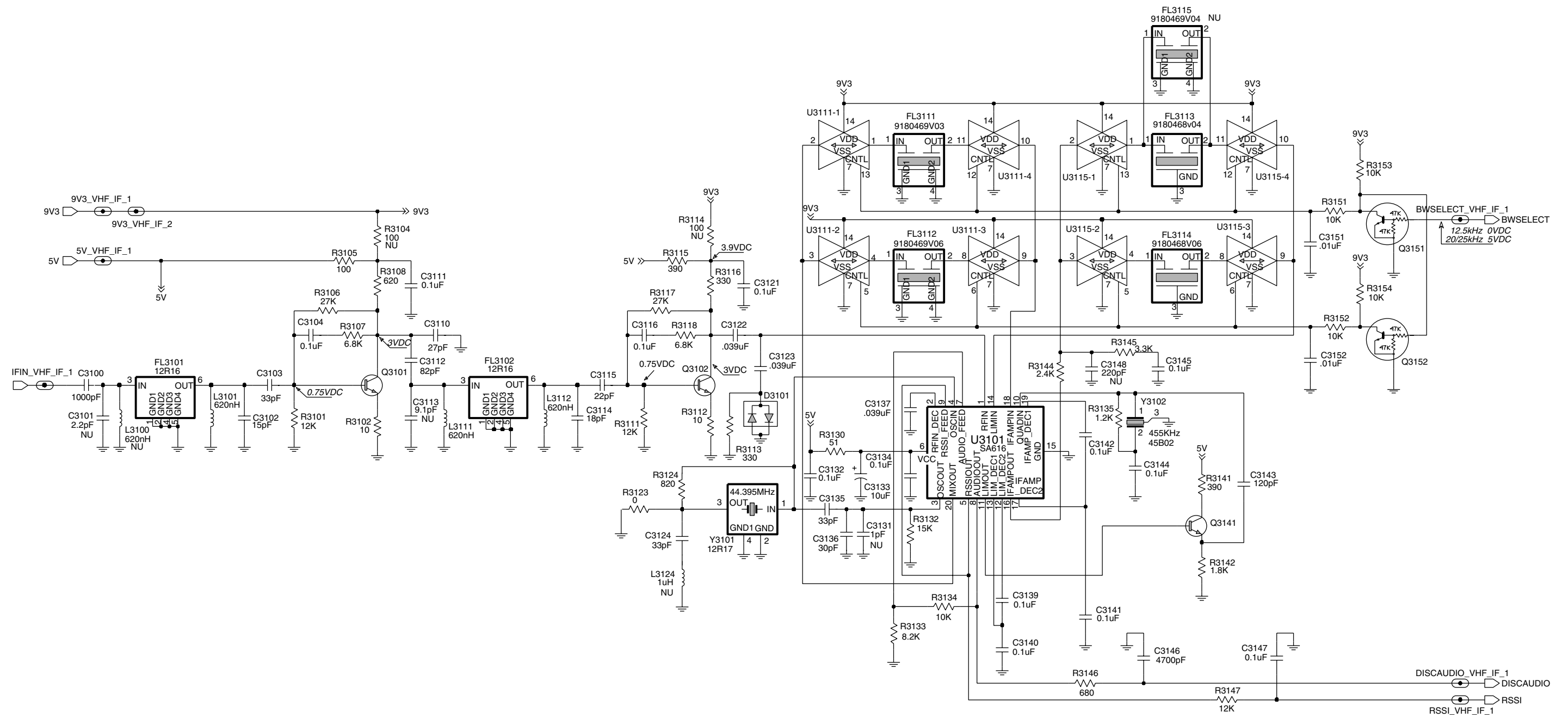

ZWG0130565-O

VHF (136-174 MHz) IF

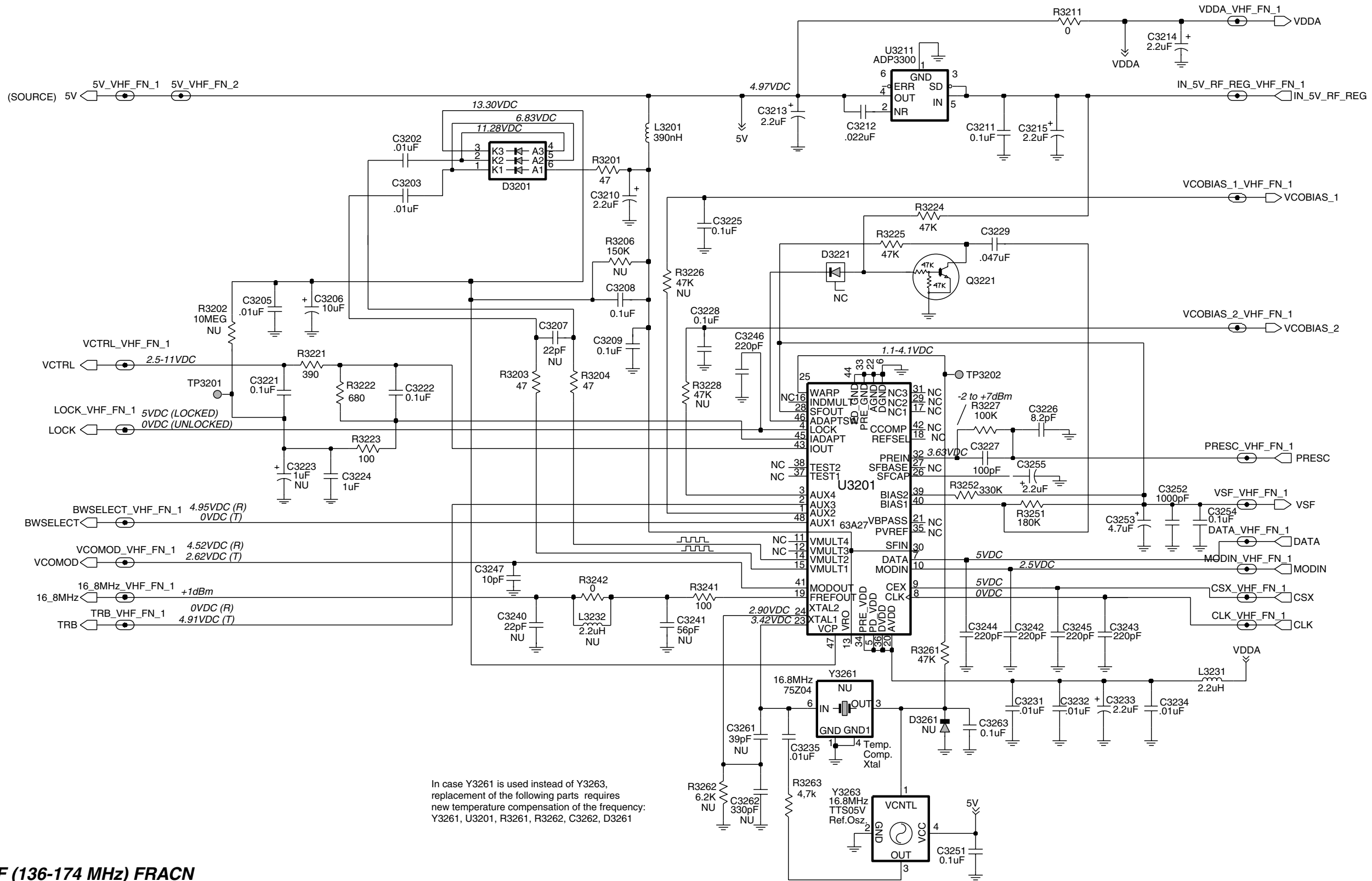

VHF (136-174 MHz) FRACN

ZWG0130564-O

4.1 VHF PCB 8486172B07 Parts List 1-25W

Circuit Ref	Motorola Part No.	Description
C3000	2113741F37	3.3nF 50V
C3001	2113740F19	4.7pF 5%
C3002	2113740F26	9.1pF 5%
C3003	2113741F37	3.3nF 50V
C3004	2113740F45	56pF 5%
C3005	2113740F51	100pF 5%
C3006	2113740F45	56pF 5%
C3007	2113741F37	3.3nF 50V
C3008	2113741F25	1nF 50V
C3009	2113741F13	330pF 50V
C3010	2113741F13	330pF 50V
C3011	2113741F37	3.3nF 50V
C3012	2113741F25	1nF 50V
C3013	2113740F45	56pF 5%
C3014	2113740F24	7.5pF 5%
C3015	2113740F45	56pF 5%
C3016	2113740F51	100pF 5% 50V
C3017	2113740F42	43pF 5% 50V
C3019	2113741F25	1nF 50V
C3020	2113741F25	1nF 50V
C3021	2113740F53	120pF 5% 50V
C3022	2113741F49	10nF 50V
C3026	2113743E20	100nF 16V
C3027	2113741F49	10nF 50V
C3028	2113741F49	10nF 50V
C3030	2113741F25	1nF 50V
C3033	2113740F20	5.1pF 5% 50V
C3034	2113740F49	82pF 5% 50V
C3035	2113740F33	18pF 5% 50V
C3036	2113741F25	1nF 50V
C3100	2113741F25	1nF 50V
C3102	2113740F31	15pF 5% 50V
C3103	2113740F39	33pF 5% 50V
C3104	2113743E20	100nF 16V
C3110	2113740F37	27pF 5% 50V
C3111	2113743E20	100nF 16V
C3112	2113740F49	82pF 5% 50V
C3114	2113740F33	18pF 5% 50V
C3115	2113740F35	22pF 5% 50V
C3116	2113743E20	100nF 16V
C3121	2113743E20	100nF 16V
C3122	2113743E11	39nF 10%
C3123	2113743E11	39nF 10%
C3124	2113740L30	33pF 2%
C3132	2113743E20	100nF 16V
C3133	2311049A57	TANT CP 10uF 10% 16V
C3134	2113743E20	100nF 16V
C3135	2113740L30	33pF 2%
C3136	2113740L29	30pF 2%
C3137	2113743E11	39nF 10%

Circuit Ref	Motorola Part No.	Description
C3139	2113743E20	100nF 16V
C3140	2113743E20	100nF 16V
C3141	2113743E20	100nF 16V
C3142	2113743E20	100nF 16V
C3143	2113740F53	120pF 5% 50V
C3144	2113743E20	100nF 16V
C3145	2113743E20	100nF 16V
C3146	2113741F41	4.7nF 50V
C3147	2113743E20	100nF 16V
C3151	2113741F49	10nF 50V
C3152	2113741F49	10nF 50V
C3202	2113741F49	10nF 50V
C3203	2113741F49	10nF 50V
C3205	2113741F49	10nF 50V
C3206	2311049A57	TANT CP 10uF 10% 16V
C3208	2113743E20	100nF 16V
C3209	2113743E20	100nF 16V
C3210	2311049A40	TANT CP 2.2uF 10% 10V
C3211	2113743E20	100nF 16V
C3212	2113743E07	22nF 16V
C3312	2113743E07	22nF 16V
C3213	2311049A40	TANT CP 2.2uF 10% 10V
C3214	2311049A09	TANT CP 2.2uF 10% 20V
C3215	2311049A09	TANT CP 2.2uF 10% 20V
C3221	2113743E20	100nF 16V
C3222	2113743E20	100nF 16V
C3224	0882422W23	FILM SM 1.0uF 15V 5%
C3225	2113743E20	100nF 16V
C3226	2113740F25	8.2pF 5% 50V
C3227	2113740F51	100pF 5% 50V
C3228	2113743E20	100nF 16V
C3229	2113743E12	47nF 10%
C3231	2113741F49	10nF 50V
C3232	2113741F49	10nF 50V
C3233	2311049A40	TANT CP 2.2uF 10%
C3234	2113741F49	10nF 50V
C3235	2113741F49	10nF 50V
C3242	2113740F59	220pF 5% 50V
C3243	2113740F59	220pF 5% 50V
C3244	2113740F59	220pF 5% 50V
C3245	2113740F59	220pF 5% 50V
C3246	2113740F59	220pF 5% 50V
C3247	2113740F27	10pF 5% 50V
C3251	2113743E20	100nF 16V
C3252	2113741F25	1nF 50V
C3253	2311049A56	TANT CP 4.7uF 20% 10V
C3254	2113743E20	100nF 16V
C3255	2311049A40	TANT CP 2.2uF 10% 10V
C3263	2113743E20	100nF 16V
C3302	2113740F23	6.8pF 5% 50V
C3303	2113741F49	10nF 50V

Circuit Ref	Motorola Part No.	Description
C3306	2113740F20	5.1pF 5% 50V
C3311	2113743E07	22nF 16V
C3314	2113740F23	6.8pF 5% 50V
C3315	2113740F31	15pF 5% 50V
C3316	2113740F15	3.3pF 5% 50V
C3317	2113740F39	33pF 5% 50V
C3318	2113740F21	5.6pF 5% 50V
C3319	2113741F25	1nF 50V
C3324	2113741F49	10nF 50V
C3332	2113743E20	100nF 16V
C3333	2113743E20	100nF 16V
C3334	2113743E07	22nF 16V
C3335	2113741F49	10nF 50V
C3336	2113741F49	10nF 50V
C3337	2113743E20	100nF 16V
C3341	2113741F25	1nF 50V
C3342	2113740L05	3.0pF +-0.1pF
C3344	2113740F09	1.8pF 5% 50V
C3345	2113740L25	20pF +-0.25pF
C3346	2113741F49	10nF 50V
C3347	2113741F49	10nF 50V
C3348	2113741F49	10nF 50V
C3351	2113741F49	10nF 50V
C3352	2113743E07	22nF 16V
C3355	2113741F49	10nF 50V
C3356	2113743E07	22nF 16V
C3357	2113740F24	7.5pF 5% 50V
C3361	2113741F25	1nF 50V
C3362	2113740F21	5.6pF 5% 50V
C3363	2113740F47	68pF 5% 50V
C3364	2113740F31	15pF 5% 50V
C3365	2113741F25	1nF 50V
C3400	2113740F63	330pF 5% 50V
C3401	2113740F63	330pF 5% 50V
C3402	2113743E07	22nF 16V
C3403	2113740F39	33pF 5% 50V
C3404	2113740F39	33pF 5% 50V
C3405	2113740F67	470pF 5% 50V
C3406	2113740F67	470pF 5% 50V
C3410	2113743E07	22nF 16V
C3411	2113743E07	22nF 16V
C3412	2113740F63	330pF 5% 50V
C3414	2113740F63	330pF 5% 50V
C3415	2113743E07	22nF 16V
C3416	2113740F63	330pF 5% 50V
C3417	2113740F43	47pF 5% 50V
C3418	2113740F39	33pF 5% 50V
C3419	2113740F57	180pF 5% 50V
C3420	2113740F57	180pF 5% 50V
C3421	2113741A57	33nF 50V
C3422	2113740A67	330pF 5% 50V

Circuit Ref	Motorola Part No.	Description
C3423	2311049A08	TANT CP 1uF 10% 35V
C3424	2113740F67	470pF 5% 50V
C3425	2113743E07	22nF 16V
C3426	2113740F63	330pF 5% 50V
C3427	2113741F33	2.2nF 50V
C3428	2113741F33	2.2nF 50V
C3431	2111078B34	HQ 47pF 5%
C3433	2111078B36	HQ 56pF 5%
C3434	2113741A45	10nF 50V
C3435	2113740A67	330pF 5% 50V
C3436	2311049A45	TANT CP 10uF 10% 35V
C3437	2113741A57	33nF 50V
C3438	2111078B59	HQ 470pF 5%
C3439	2111078B59	HQ 470pF 5%
C3440	2113741F25	1nF 50V
C3441	2111078B47	HQ 150pF 5%
C3442	2111078B47	HQ 150pF 5%
C3445	2111078B21	HQ 20pF 5%
C3446	2111078B42	HQ 100pF 5%
C3447	2111078B19	HQ 16pF 5%
C3448	2111078B44	HQ 120pF 5%
C3449	2111078B44	HQ 120pF 5%
C3450	2113740F67	470pF 5% 50V
C3451	2113741F25	1nF 50V
C3452	2113740F29	12pF 5% 50V
C3453	2113740F67	470pF 5% 50V
C3471	2113743E07	22nF 16V
C3472	2111078B53	HQ 270pF 5%
C3473	2111078B53	HQ 270pF 5%
C3474	2113740F59	220pF 5% 50V
C3475	2113740F23	6.8pF 5% 50V
C3491	2111078B18	HQ 15pF 5%
C3492	2111078B38	HQ 68pF 5%
C3493	2111078B09	HQ 6.8pF 5%
C3494	2111078B16	HQ 13pF 5%
C3495	2111078B01	HQ 3.3pF 5%
C3496	2111078B31	HQ 36pF 5%
C3498	2111078B16	HQ 13pF 5%
C3499	2111078B19	HQ 16pF 5%
C3501	2113741F33	2.2nF 50V
C3502	2113741F33	2.2nF 50V
C3503	2113740F67	470pF 5% 50V
C3504	2113741F49	10nF 50V
C3505	2311049A07	TANT CP 1uF 10% 16V
C3506	2113741F33	2.2nF 50V X7R
C3507	2113740F51	100pF 5% 50V
C3508	2113740F67	470pF 5% 50V
C3510	2113740F67	470pF 5% 50V
D3000	4813833C02	DUAL SOT MMBD6100
D3001	4805649Q13	VCTR 1SV228 SOT23
D3003	4880154K03	DUAL SCHOTTKY SOT23

Circuit Ref	Motorola Part No.	Description
D3004	4805649Q13	VCTR 1SV228 SOT23
D3011	4880142L01	PIN
D3031	4886143B01	MIXER DIODE CROSSOVER
D3101	4880154K03	DIODE DUAL SCHOTTKY
D3201	4802233J09	TRIPLE SOT143-RH
D3221	4880236E05	CHIP SCHOTTKY
D3341	4805649Q13	VCTR 1SV228 SOT23
D3361	4805649Q13	VCTR 1SV228 SOT23
D3362	4862824C01	VARACTOR CHIP
D3401	4813833C02	DUAL SOT MMBD6100
D3451	4880236E05	CHIP SCHOTTKY
D3471	4802482J02	PIN MA/COM
D3472	4802482J02	PIN MA/COM
FL3101	9180112R16	44.85MHZ CRYSTAL FLTR 80dB
FL3102	9180112R16	44.85 MHZ CRYSTAL FLTR 80dB
FL3111	9180469V03	CER FLTR 6EL 455 KHZ SMD
FL3112	9180469V06	CER FLTR 6EL 455 KHZ SMD
FL3113	9180468V04	CER FLTR 4EL 455 KHZ SMD
FL3114	9180468V06	CER FLTR 4EL 455 KHZ SMD
J3401	0986166B02	RF CONN MINI UHF
L3002	2462587T23	COIL CHIP 470nH
L3031	2462587T24	COIL CHIP 560nH
L3032	2462587T17	COIL CHIP 150nH
L3101	2462587T25	COIL CHIP 620nH
L3111	2462587T25	COIL CHIP 620nH
L3112	2462587T25	COIL CHIP 620nH
L3124	2462587N68	1uH
L3201	2462587Q42	IND CHIP 390nH 10%
L3231	2462587Q20	IND CHIP 2.2uH 20%
L3301	2462587N44	CHIP IND 18 NH 5%
L3302	2462587N53	CHIP IND 100 nH 5%
L3317	2462587V28	CHIP IND 33 NH 5%
L3318	2462587V34	IND CHIP 100nH 5%
L3331	2462587V32	CHIP IND 68NH 5%
L3332	2462587V15	IND CHIP 100nH 10%
L3333	2462587Q47	IND CHIP 1uH 10%
L3341	2484562T13	MINI-SPRING AW IND 8NH 2%
L3343	2462587N56	COIL CHIP 180nH 5%
L3344	2462587N68	CHIP IND 1 uH 5%
L3345	2462587N68	CHIP IND 1 uH 5%
L3346	2484562T18	MINI-SPRING AW IND 35.5NH 2%
L3351	2462587N68	CHIP IND 1 uH 5%
L3361	2462587N50	CHIP IND 56 nH 5%
L3362	2462587N51	CHIP IND 68 nH 5%
L3363	2462587N50	CHIP IND 56 nH 5%
L3364	2462587N68	CHIP IND 1 uH 5%
L3401	2460591A01	SQUARE COIL 4.22nH 3T

Circuit Ref	Motorola Part No.	Description
L3402	2484657R01	Ferrite Bead
L3403	2462587T13	COIL CHIP 68nH
L3411	2462587T13	COIL CHIP 68nH
L3412	2462587X43	IND CHIP LO-PRO 15.0
L3413	2460591B04	SQUARE COIL 11.03nH 4T
L3414	2460591A11	SQUARE COIL 7.66nH 3T
L3421	2484657R01	Ferrite Bead
L3422	2460591C23	SQUARE COIL 16nH 3T
L3436	2484657R01	Ferrite Bead
L3437	2460592A01	COIL AW 17nH 2T
L3443	2460591X02	COIL SQUARE 25nH
L3471	2462587X69	IND CHIP 1.2uH 5%
L3472	2460592B01	COIL AW 51nH 4T
L3491	2460592B01	COIL AW 51nH 4T
L3492	2460592B01	COIL AW 51nH 4T
L3493	2460592B01	COIL AW 51nH 4T
M3421	2686201B01	HEAT SPREADER
Q3001	4813827A07	TSTR NPN SML SIG MMBR9
Q3002	4813824A17	TSTR PNP 40V .2A B=100-
Q3021	4805921T02	TSTR DUAL ROHM FMC2
Q3101	4813827A07	TSTR NPN SML SIG MMBR9
Q3102	4813827A07	TSTR NPN SML SIG MMBR9
Q3141	4813824A10	TSTR NPN 40V .2A B=50-150
Q3151	4880048M01	TSTR NPN DIG 47k/47k
Q3152	4880048M01	TSTR NPN DIG 47k/47k
Q3221	4880048M01	TSTR NPN DIG 47k/47k
Q3301	4813827A07	TSTR NPN SML SIG MMBR9
Q3303	4802245J50	TSTR DUAL NPN/PNP UMC5N
Q3304	4805218N63	RF TRANS SOT 323 BFQ67W
Q3411	4805921T02	DUAL ROHM FMC2 RH
Q3421	4802245J55	MRF1507
Q3422	4880048M01	NPN DIG 47k/47k
Q3441	4886136B01	LD MOS PWR TSTR MRF1565 MRF1550
Q3442	4880048M01	NPN DIG 47k/47k
Q3471	4880048M01	NPN DIG 47k/47k
Q3472	4805128M27	PNP SOT89 BSR33 LH
R3000	0662057A53	1k5 1/16W 5%
R3001	0662057A97	100k 1/16W
R3002	0662057A43	560 1/16W 5%
R3003	0662057A49	1k 1/16W 5%
R3004	0662057A53	1k5 1/16W 5%
R3006	0662057A73	10k 1/16W 5%
R3009	0662057A97	100k 1/16W
R3010	0662057A45	680 OHMS 5%
R3011	0662057A65	4k7 1/16W 5%
R3012	0662057A49	1k 1/16W 5%
R3013	0662057A61	3k3 1/16W 5%
R3014	0662057A18	51 1/16W 5%

Circuit Ref	Motorola Part No.	Description
R3015	0662057A01	10 1/16W 5%
R3016	0662057A01	10 1/16W 5%
R3018	0662057A33	220 1/16W 5%
R3019	0662057A89	47k 1/16W 5%
R3021	0662057A43	560 1/16W 5%
R3024	0662057A39	390 1/16W 5%
R3025	0662057A53	1k5 1/16W 5%
R3026	0662057A73	10k 1/16W 5%
R3027	0662057A73	10k 1/16W 5%
R3028	0662057A39	390 1/16W 5%
R3031	0662057A18	51 1/16W 5%
R3033	0662057B47	0 1/16W
R3101	0662057A75	12k 1/16W 5%
R3102	0662057A01	10 1/16W 5%
R3105	0662057A25	100 1/16W 5%
R3106	0662057A83	27k 1/16W 5%
R3107	0662057A69	6k8 1/16W 5%
R3108	0662057A44	620 OHMS 5%
R3111	0662057A75	12k 1/16W 5%
R3112	0662057A01	10 1/16W 5%
R3113	0662057A37	330 1/16W 5%
R3115	0662057A39	390 1/16W 5%
R3116	0662057A37	330 1/16W 5%
R3117	0662057A83	27k 1/16W 5%
R3118	0662057A69	6k8 1/16W 5%
R3123	0662057B47	0 1/16W
R3124	0662057A47	820 1/16W
R3130	0662057A18	51 1/16W 5%
R3132	0662057A77	15k 1/16W 5%
R3133	0662057A71	8k2 1/16W 5%
R3134	0662057A73	10k 1/16W 5%
R3135	0662057A51	1k2 1/16W 5%
R3141	0662057A39	390 1/16W 5%
R3142	0662057A55	1k8 1/16W 5%
R3144	0662057A58	2k4 1/16W 5%
R3145	0662057A61	3k3 1/16W 5%
R3146	0662057A45	680 OHMS 5%
R3147	0662057A75	12k 1/16W 5%
R3151	0662057A73	10k 1/16W 5%
R3152	0662057A73	10k 1/16W 5%
R3153	0662057A73	10k 1/16W 5%
R3154	0662057A73	10k 1/16W 5%
R3201	0662057A17	47 1/16W 5%
R3202	0662057B46	10MEG
R3203	0662057A17	47 1/16W 5%
R3204	0662057A17	47 1/16W 5%
R3206	0662057B02	150k 1/16W
R3211	0662057B47	0 1/16W
R3221	0662057A39	390 1/16W 5%
R3222	0662057A45	680 OHMS 5%
R3223	0662057A25	100 1/16W 5%

Circuit Ref	Motorola Part No.	Description
R3224	0662057A89	47k 1/16W 5%
R3225	0662057A89	47k 1/16W 5%
R3227	0662057A97	100k 1/16W
R3241	0662057A25	100 1/16W 5%
R3242	0662057B47	0 1/16W
R3251	0662057B04	180k 1/16W 5%
R3252	0662057B10	330k 1/16W 5%
R3261	0662057A89	47k 1/16W 5%
R3263	0662057A65	4k7 1/16W 5%
R3301	0662057A22	75 1/16W 5%
R3302	0662057A25	100 1/16W 5%
R3303	0662057A57	2k2 1/16W 5%
R3304	0662057A49	1k 1/16W 5%
R3308	0662057B47	0 1/16W
R3311	0662057A25	100 1/16W 5%
R3316	0662057B47	0 1/16W
R3318	0662057A09	22 1/16W 5%
R3321	0662057A73	10k 1/16W 5%
R3323	0662057A49	1k 1/16W 5%
R3331	0662057A17	47 1/16W 5%
R3335	0662057A13	33 1/16W 5%
R3336	0662057A77	15k 1/16W 5%
R3341	0662057A33	220 1/16W 5%
R3342	0662057A15	39 1/16W 5%
R3343	0662057A25	100 1/16W 5%
R3351	0662057A80	20k 1/16W 5%
R3352	0662057A75	12k 1/16W 5%
R3353	0662057A97	100k 1/16W
R3354	0662057B02	150k 1/16W
R3355	0662057A80	20k 1/16W 5%
R3356	0662057A75	12k 1/16W 5%
R3361	0662057A33	220 1/16W 5%
R3362	0662057A17	47 1/16W 5%
R3364	0662057A89	47k 1/16W 5%
R3400	0662057A41	470 1/16W 5%
R3401	0662057A36	300 1/16W 5%
R3402	0662057A05	15 1/16W 5%
R3403	0662057A36	300 1/16W 5%
R3404	0662057A89	47k 1/16W 5%
R3405	0662057A25	100 1/16W 5%
R3406	0662057A97	100k 1/16W
R3412	0662057A67	5k6 1/16W 5%
R3413	0662057A61	3k3 1/16W 5%
R3414	0683962T51	120 1W 5%
R3415	0662057A25	100 1/16W 5%
R3416	0662057A25	100 1/16W 5%
R3418	0662057A81	22k 1/16W 5%
R3421	0662057A87	39k 1/16W 5%
R3422	0662057A57	2k2 1/16W 5%
R3423	0662057A87	39k 1/16W 5%
R3424	0662057C13	2R7 1/10W 5%

Circuit Ref	Motorola Part No.	Description
R3425	0662057C13	2R7 1/10W 5%
R3426	0662057C13	2R7 1/10W 5%
R3427	0662057C13	2R7 1/10W 5%
R3428	0662057A58	2k4 1/16W 5%
R3429	0662057A33	220 1/16W 5%
R3431	0680194M18	51 1W 5%
R3432	0680194M18	51 1W 5%
R3433	0662057C13	2R7 1/10W 5%
R3434	0662057C13	2R7 1/10W 5%
R3435	0662057C13	2R7 1/10W 5%
R3441	0662057A87	39k 1/16W 5%
R3442	0662057A57	2k2 1/16W 5%
R3443	0662057A87	39k 1/16W 5%
R3444	0662057C19	4R7 1/10W 5%
R3445	0662057A58	2k4 1/16W 5%
R3446	0662057B47	0 1/16W
R3450	0662057A41	470 1/16W 5%
R3452	0662057A75	12k 1/16W 5%
R3454	0662057A84	30k 1/16W 5%
R3455	0662057A97	100k 1/16W
R3457	0683962T51	120 1W 5%
R3471	0662057A41	470 1/16W 5%
R3473	0680194M18	51 1W 5%
R3474	0680194M18	51 1W 5%
R3475	0662057A73	10k 1/16W 5%
R3491	0662057A73	10k 1/16W 5%
R3501	0662057A69	6k8 1/16W 5%
R3502	0662057A87	39k 1/16W 5%
R3504	0662057A73	10k 1/16W 5%
R3505	0662057B09	300k 1/16W 5%
R3507	0662057A80	20k 1/16W 5%
R3508	0662057A97	100k 1/16W
R3509	0662057A49	1k 1/16W 5%
T3001	2508396X02	TRANSFORMER
T3002	2508397X02	TRANSFORMER
U3101	5186144B01	FM IF IC SA616
U3111	5113805A86	IC QUAD ANALOG MUX/ DEMUX
U3115	5113805A86	IC QUAD ANALOG MUX/ DEMUX
U3201	5185963A27	IC TESTED AT25016 48 PIN GFP
U3211	5105739X05	IC SOT 5V HI-PRECISION REGULAT
U3301	5105750U54	VCO BUFFER PKG DIE
U3401	5105109Z67	LD MOS DRIVER VHF/UHF
U3402	5180932W01	LINEAR IC OP AMP
U3501	5185765B01	IC POWER CONTROL
U3502	5185963A15	TEMP SENSOR 1M5
VR3471	4813830A15	5.6V 5% 225mW
Y3101	4880606B09	CRYSTAL 44.395 MHZ

Circuit Ref	Motorola Part No.	Description
Y3102	9186145B02	CERAMIC DISCRIMINATOR 455kHz
Y3263	4886182B01	VCTCXO 16.8MHz 2ppm TTSO5V
* Y3261	Not Used	16.8MHz 75Z04

* Motorola Depot Servicing only

Reference designators with an asterisk indicate components which are not fieldreplaceable because they need to be calibrated with specialized factory equipment after installation. Radios in which these parts have been replaced in the field will be off frequency at temperature extremes.

5.0 VHF 1-25W PCB 8486172B08 / Schematics

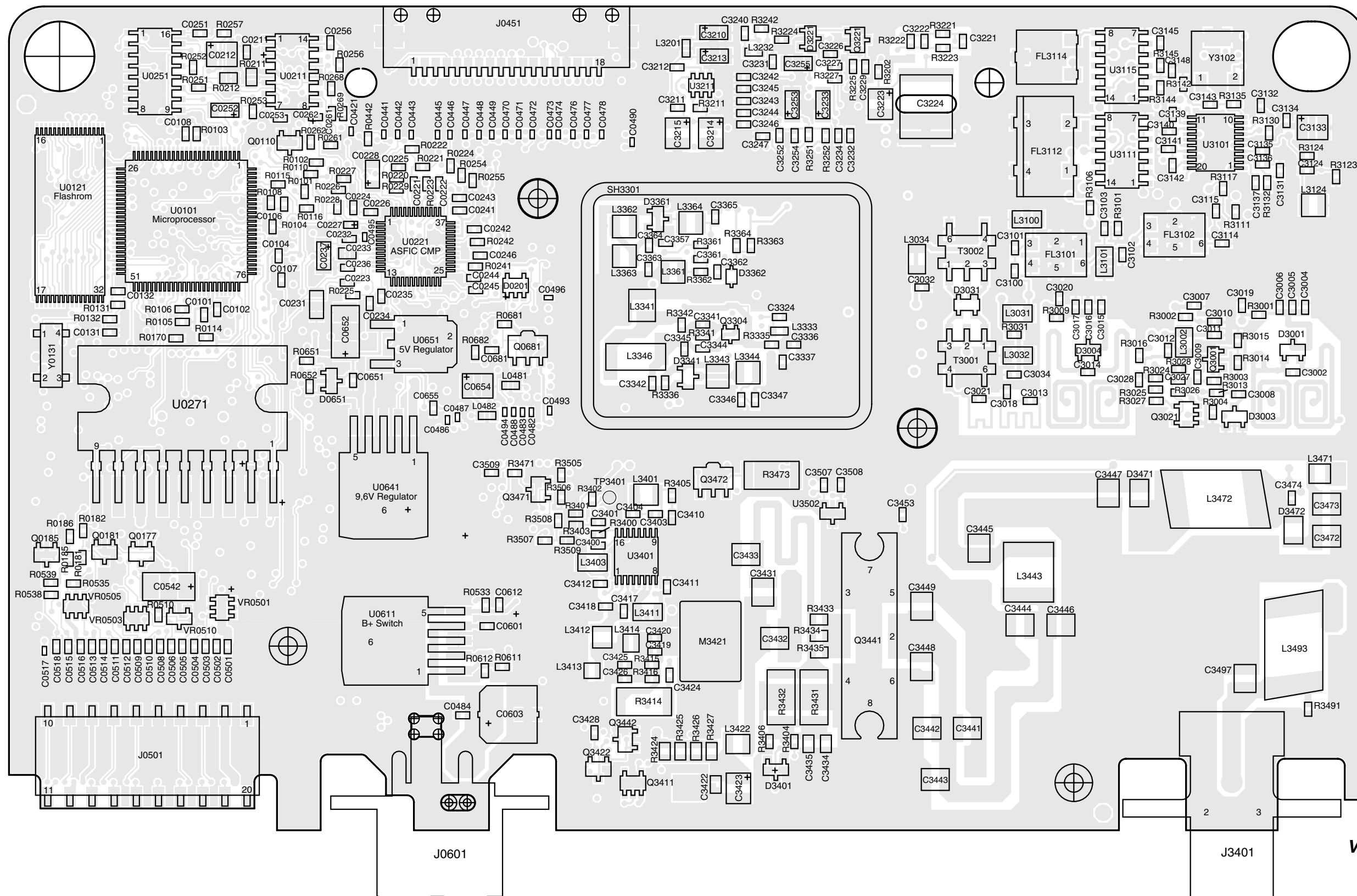

ZWG0130591-O

VHF (136-174 MHz) 1-25W
8486172B08 Top Side

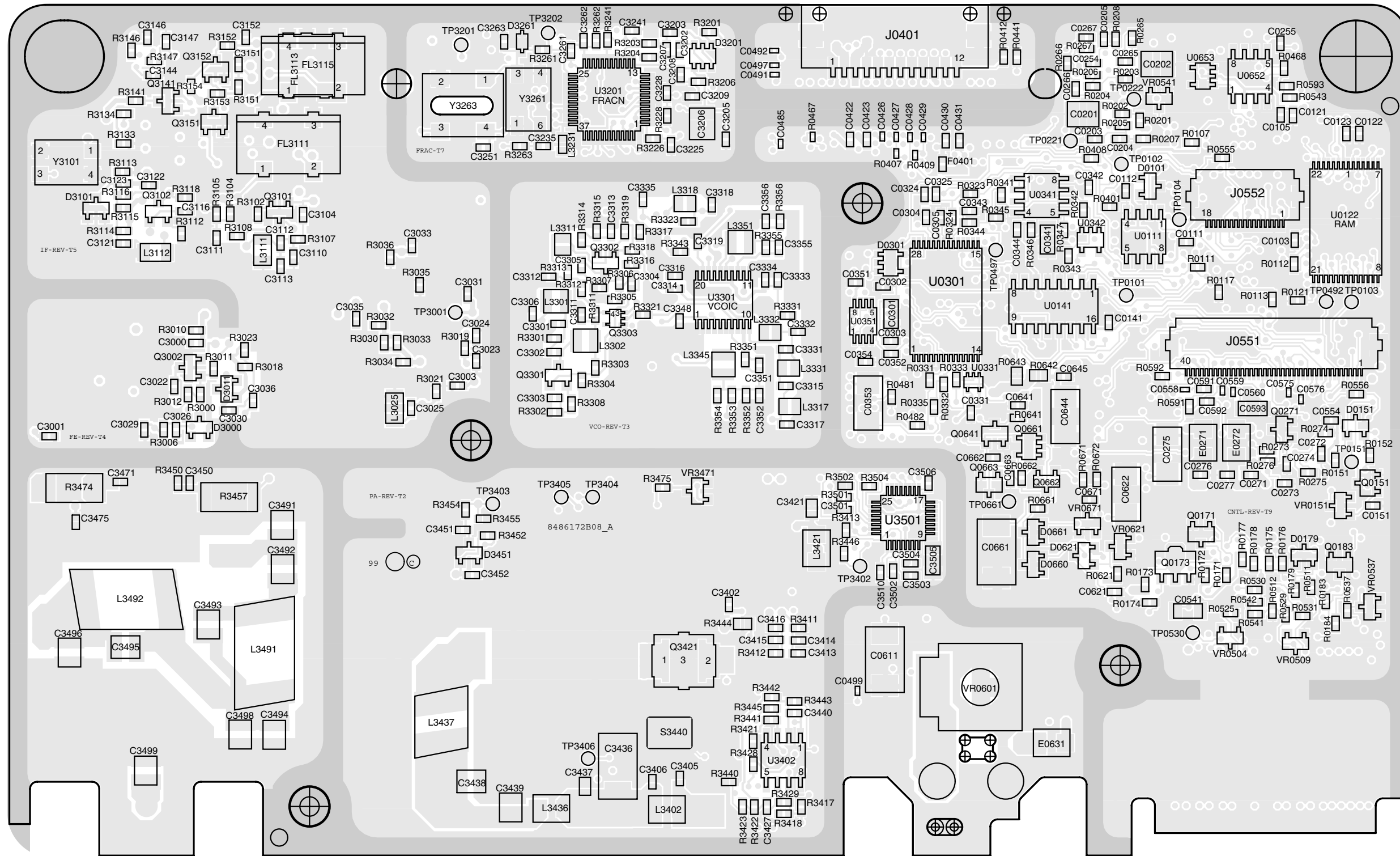

ZWG01300592-O

VHF (136-174 MHz) 1-25W 8486172B08 Bottom Side

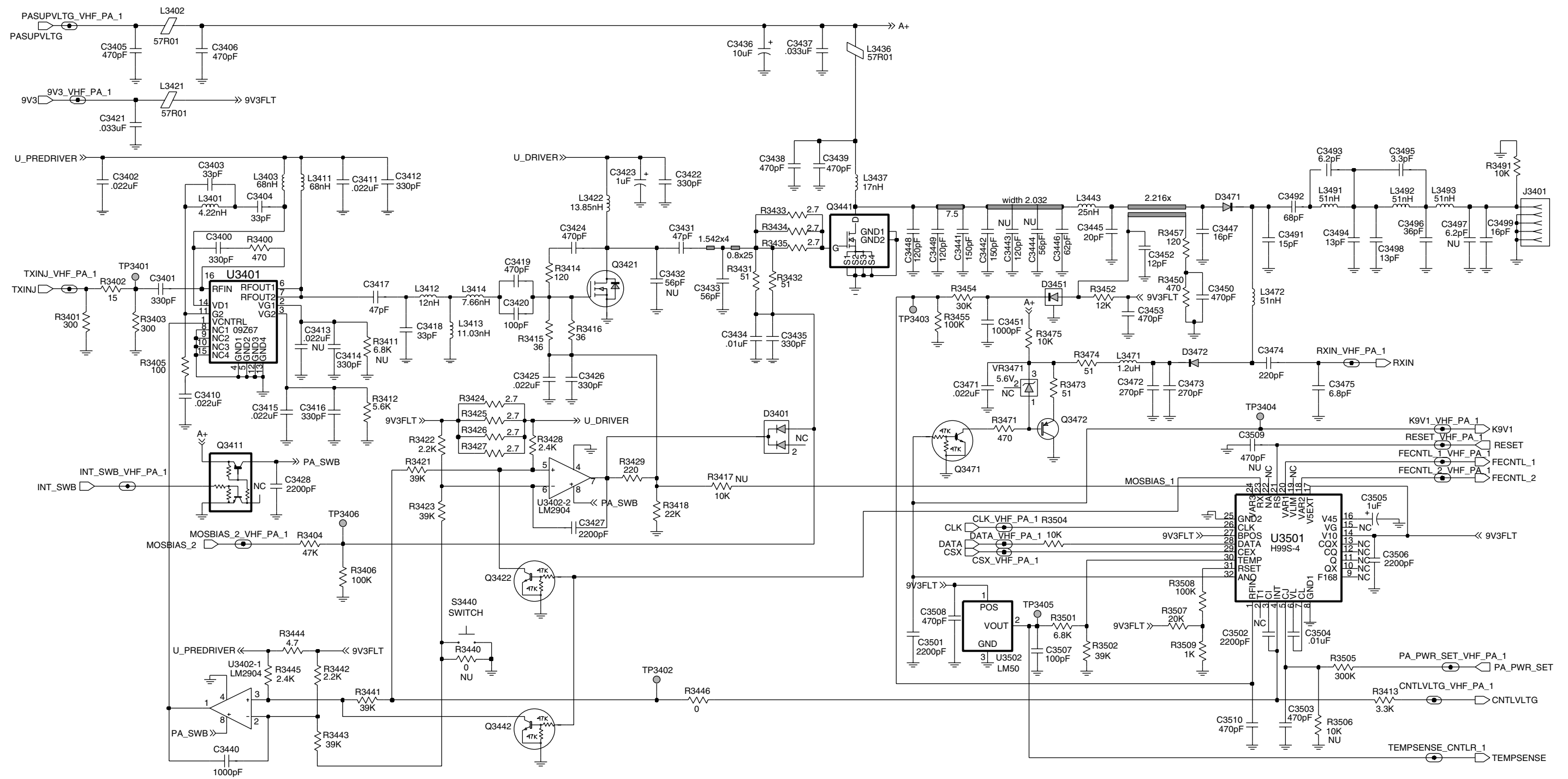

VHF (136-174 MHz) Power Amplifier 1 - 25W

ZWG0130628-O

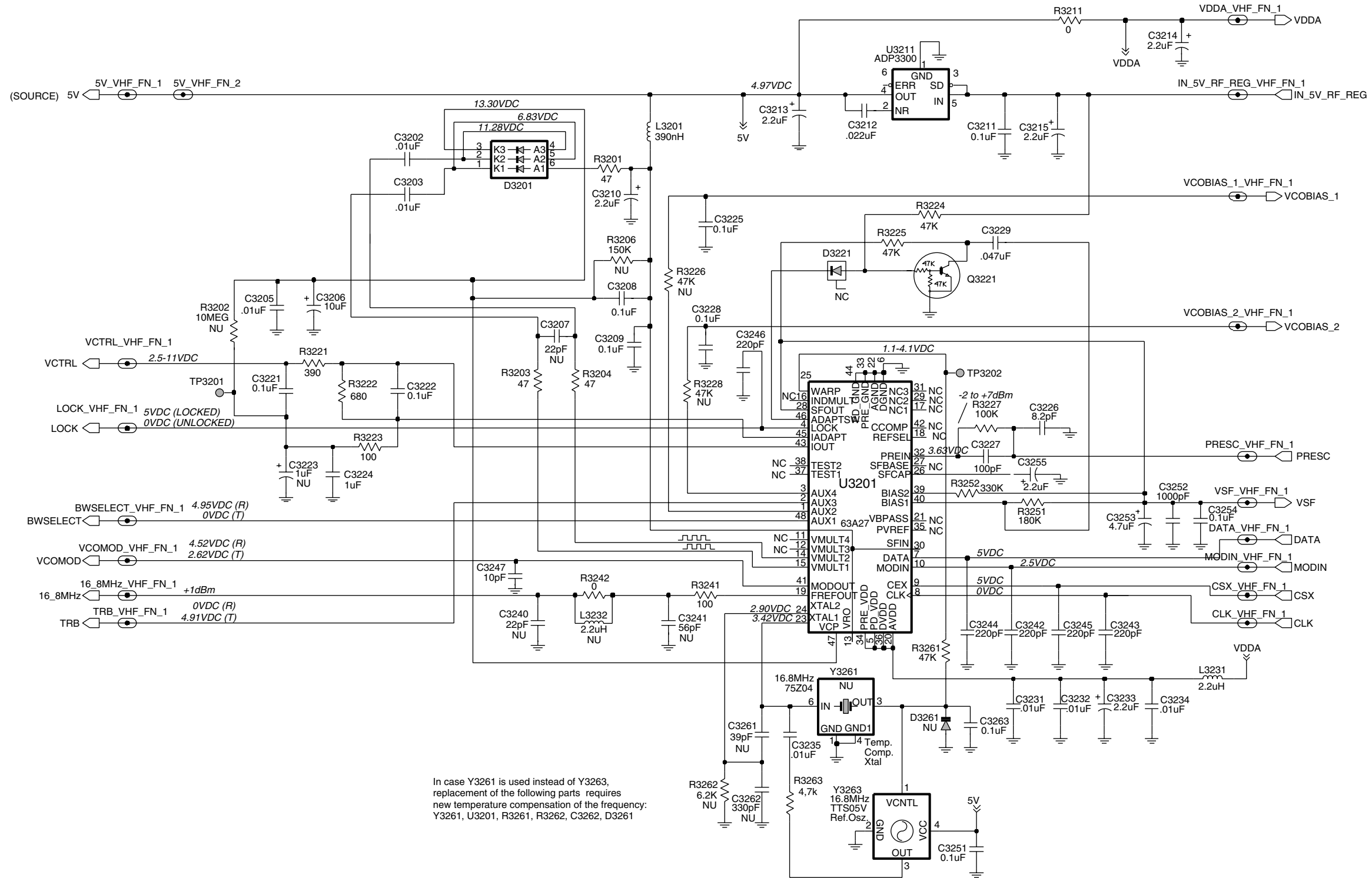

ZWG0130564-O

VHF (136-174 MHz) FRACN

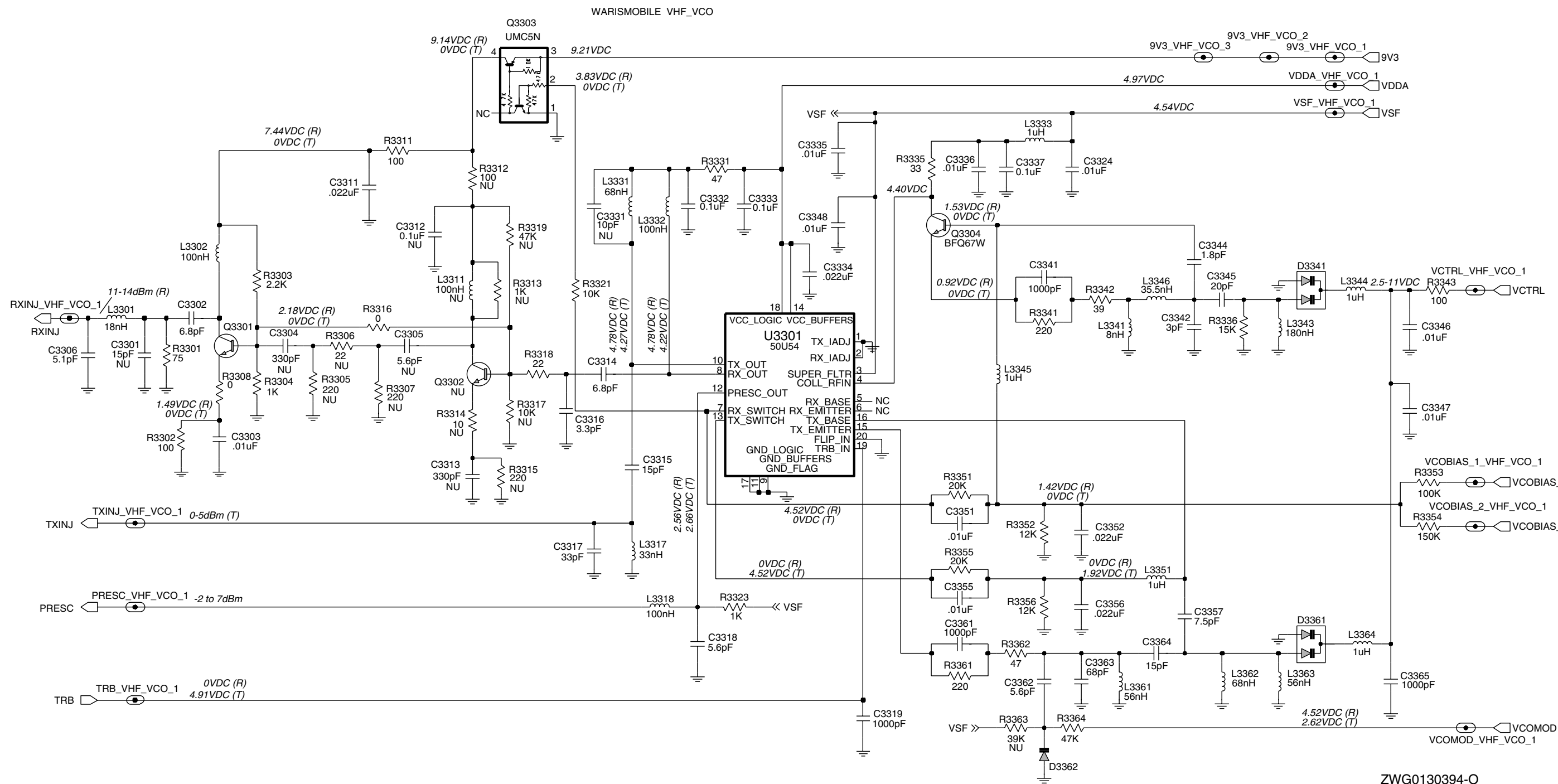

ZWG0130394-O

VHF (136-174 MHz) Voltage Controlled Oscillator

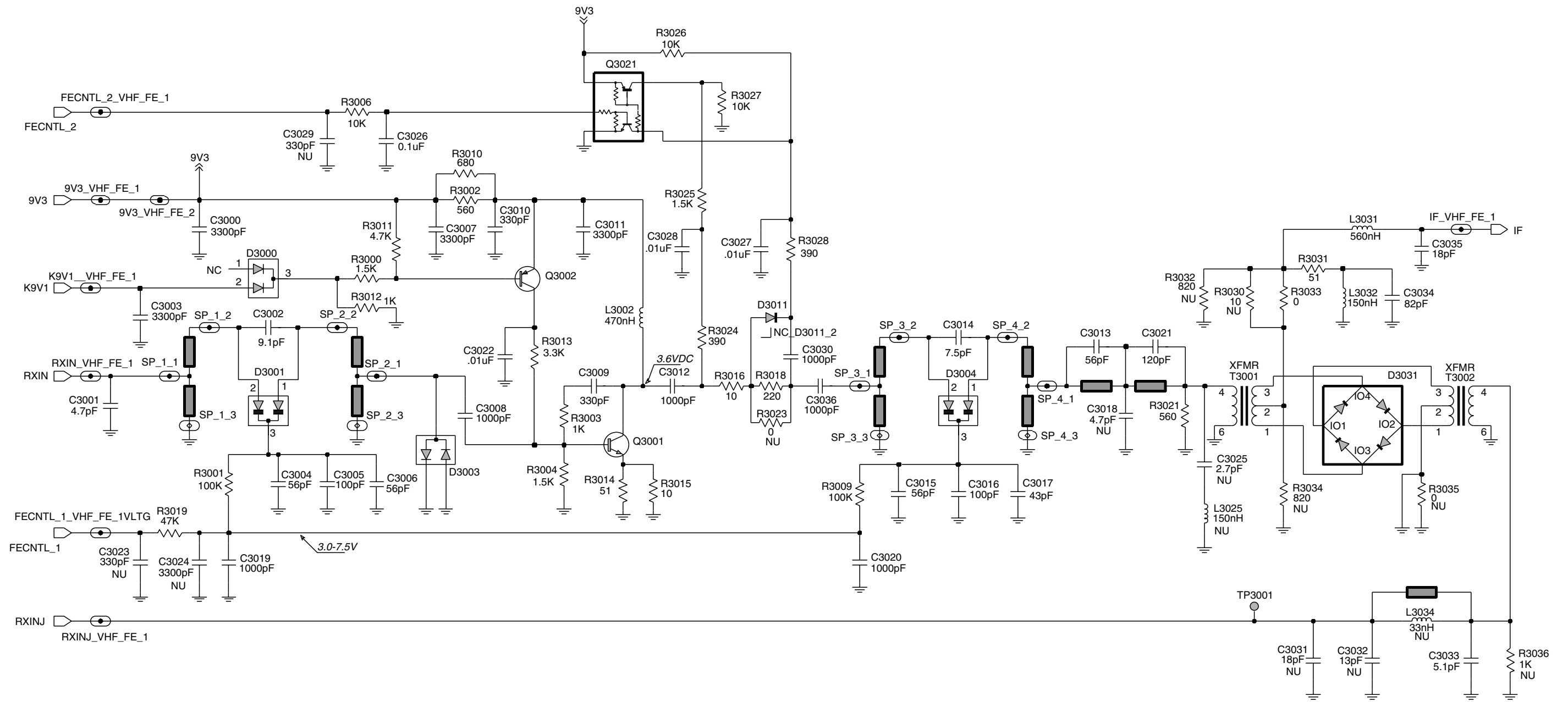

VHF (136-174 MHz) Receiver Front End

ZWG0130395-A

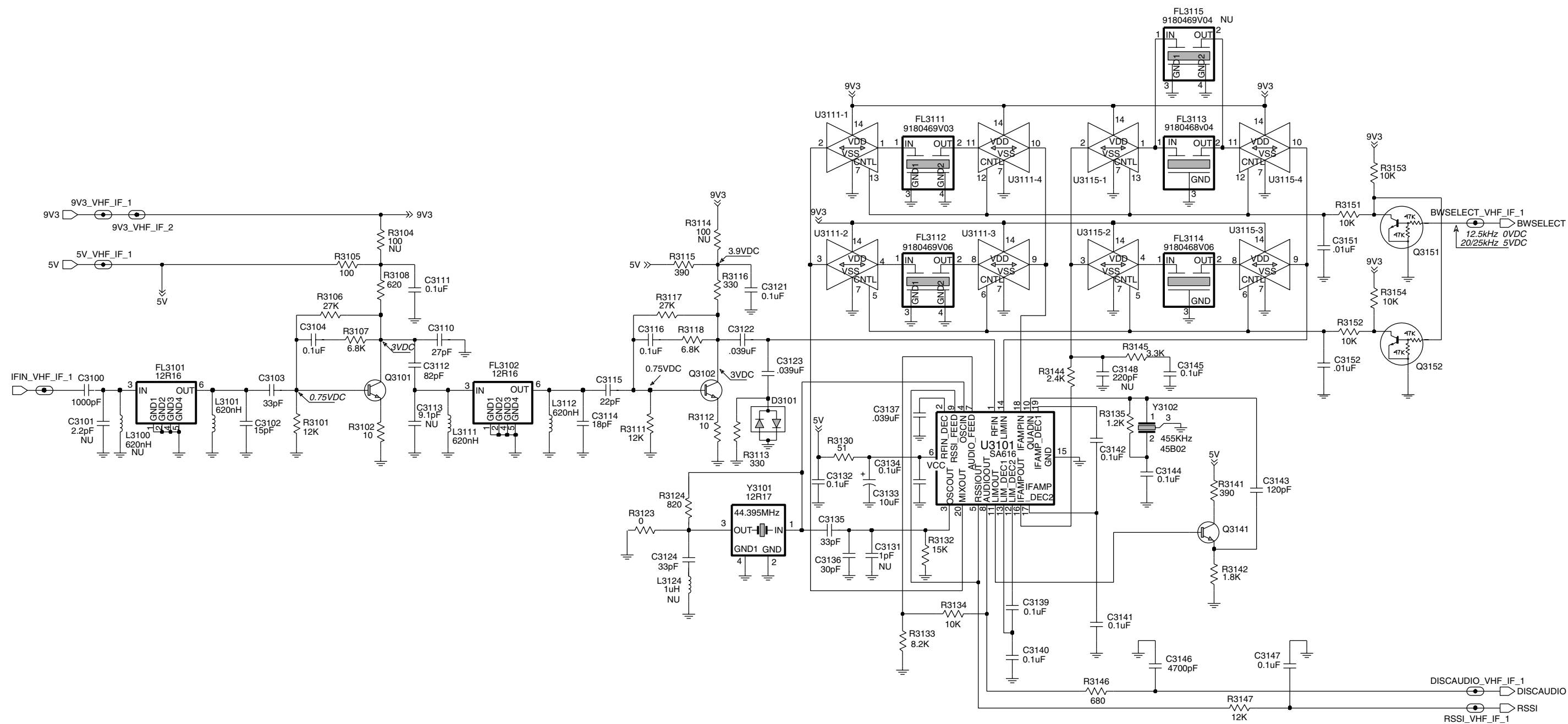

ZWG0130565-A

VHF (136-174 MHz) IF

5.1 VHF PCB 8486172B08 Parts List 1-25W

Circuit Ref	Motorola Part No.	Description
C3000	2113741F37	3.3nF 50V
C3001	2113740F19	4.7pF 5%
C3002	2113740F26	9.1pF 5%
C3003	2113741F37	3.3nF 50V
C3004	2113740F45	56pF 5%
C3005	2113740F51	100pF 5%
C3006	2113740F45	56pF 5%
C3007	2113741F37	3.3nF 50V
C3008	2113741F25	1nF 50V
C3009	2113741F13	330pF 50V
C3010	2113741F13	330pF 50V
C3011	2113741F37	3.3nF 50V
C3012	2113741F25	1nF 50V
C3013	2113740F45	56pF 5%
C3014	2113740F24	7.5pF 5%
C3015	2113740F45	56pF 5%
C3016	2113740F51	100pF 5% 50V
C3017	2113740F42	43pF 5% 50V
C3019	2113741F25	1nF 50V
C3020	2113741F25	1nF 50V
C3021	2113740F53	120pF 5% 50V
C3022	2113741F49	10nF 50V
C3026	2113743E20	100nF 16V
C3027	2113741F49	10nF 50V
C3028	2113741F49	10nF 50V
C3030	2113741F25	1nF 50V
C3033	2113740F20	5.1pF 5% 50V
C3034	2113740F49	82pF 5% 50V
C3035	2113740F33	18pF 5% 50V
C3036	2113741F25	1nF 50V
C3100	2113741F25	1nF 50V
C3102	2113740F31	15pF 5% 50V
C3103	2113740F39	33pF 5% 50V
C3104	2113743E20	100nF 16V
C3110	2113740F37	27pF 5% 50V
C3111	2113743E20	100nF 16V
C3112	2113740F49	82pF 5% 50V
C3114	2113740F33	18pF 5% 50V
C3115	2113740F35	22pF 5% 50V
C3116	2113743E20	100nF 16V
C3121	2113743E20	100nF 16V
C3122	2113743E11	39nF 10%
C3123	2113743E11	39nF 10%
C3124	2113740L30	33pF 2%
C3132	2113743E20	100nF 16V
C3133	2311049A57	TANT CP 10uF 10% 16V
C3134	2113743E20	100nF 16V
C3135	2113740L30	33pF 2%
C3136	2113740L29	30pF 2%
C3137	2113743E11	39nF 10%

Circuit Ref	Motorola Part No.	Description
C3139	2113743E20	100nF 16V
C3140	2113743E20	100nF 16V
C3141	2113743E20	100nF 16V
C3142	2113743E20	100nF 16V
C3143	2113740F53	120pF 5% 50V
C3144	2113743E20	100nF 16V
C3145	2113743E20	100nF 16V
C3146	2113741F41	4.7nF 50V
C3147	2113743E20	100nF 16V
C3151	2113741F49	10nF 50V
C3152	2113741F49	10nF 50V
C3202	2113741F49	10nF 50V
C3203	2113741F49	10nF 50V
C3205	2113741F49	10nF 50V
C3206	2311049A57	TANT CP 10uF 10% 16V
C3208	2113743E20	100nF 16V
C3209	2113743E20	100nF 16V
C3210	2311049A40	TANT CP 2.2uF 10% 10V
C3211	2113743E20	100nF 16V
C3212	2113743E07	22nF 16V
C3312	2113743E07	22nF 16V
C3213	2311049A40	TANT CP 2.2uF 10% 10V
C3214	2311049A09	TANT CP 2.2uF 10% 20V
C3215	2311049A09	TANT CP 2.2uF 10% 20V
C3221	2113743E20	100nF 16V
C3222	2113743E20	100nF 16V
C3224	0882422W23	FILM SM 1.0uF 15V 5%
C3225	2113743E20	100nF 16V
C3226	2113740F25	8.2pF 5% 50V
C3227	2113740F51	100pF 5% 50V
C3228	2113743E20	100nF 16V
C3229	2113743E12	47nF 10%
C3231	2113741F49	10nF 50V
C3232	2113741F49	10nF 50V
C3233	2311049A40	TANT CP 2.2uF 10%
C3234	2113741F49	10nF 50V
C3235	2113741F49	10nF 50V
C3242	2113740F59	220pF 5% 50V
C3243	2113740F59	220pF 5% 50V
C3244	2113740F59	220pF 5% 50V
C3245	2113740F59	220pF 5% 50V
C3246	2113740F59	220pF 5% 50V
C3247	2113740F27	10pF 5% 50V
C3251	2113743E20	100nF 16V
C3252	2113741F25	1nF 50V
C3253	2311049A56	TANT CP 4.7uF 20% 10V
C3254	2113743E20	100nF 16V
C3255	2311049A40	TANT CP 2.2uF 10% 10V
C3263	2113743E20	100nF 16V
C3302	2113740F23	6.8pF 5% 50V
C3303	2113741F49	10nF 50V

Circuit Ref	Motorola Part No.	Description
C3306	2113740F20	5.1pF 5% 50V
C3311	2113743E07	22nF 16V
C3314	2113740F23	6.8pF 5% 50V
C3315	2113740F31	15pF 5% 50V
C3316	2113740F15	3.3pF 5% 50V
C3317	2113740F39	33pF 5% 50V
C3318	2113740F21	5.6pF 5% 50V
C3319	2113741F25	1nF 50V
C3324	2113741F49	10nF 50V
C3332	2113743E20	100nF 16V
C3333	2113743E20	100nF 16V
C3334	2113743E07	22nF 16V
C3335	2113741F49	10nF 50V
C3336	2113741F49	10nF 50V
C3337	2113743E20	100nF 16V
C3341	2113741F25	1nF 50V
C3342	2113740L05	3.0pF +-0.1pF
C3344	2113740F09	1.8pF 5% 50V
C3345	2113740L25	20pF +-0.25pF
C3346	2113741F49	10nF 50V
C3347	2113741F49	10nF 50V
C3348	2113741F49	10nF 50V
C3351	2113741F49	10nF 50V
C3352	2113743E07	22nF 16V
C3355	2113741F49	10nF 50V
C3356	2113743E07	22nF 16V
C3357	2113740F24	7.5pF 5% 50V
C3361	2113741F25	1nF 50V
C3362	2113740F21	5.6pF 5% 50V
C3363	2113740F47	68pF 5% 50V
C3364	2113740F31	15pF 5% 50V
C3365	2113741F25	1nF 50V
C3400	2113740F63	330pF 5% 50V
C3401	2113740F63	330pF 5% 50V
C3402	2113743E07	22nF 16V
C3403	2113740F39	33pF 5% 50V
C3404	2113740F39	33pF 5% 50V
C3405	2113740F67	470pF 5% 50V
C3406	2113740F67	470pF 5% 50V
C3410	2113743E07	22nF 16V
C3411	2113743E07	22nF 16V
C3412	2113740F63	330pF 5% 50V
C3414	2113740F63	330pF 5% 50V
C3415	2113743E07	22nF 16V
C3416	2113740F63	330pF 5% 50V
C3417	2113740F43	47pF 5% 50V
C3418	2113740F39	33pF 5% 50V
C3419	2113740F63	330pF 5% 50V
C3420	2113740F63	330pF 5% 50V
C3421	2113741A57	33nF 50V
C3422	2113740A67	330pF 5% 50V

Circuit Ref	Motorola Part No.	Description
C3423	2311049A08	TANT CP 1uF 10% 35V
C3424	2113740F67	470pF 5% 50V
C3425	2113743E07	22nF 16V
C3426	2113740F63	330pF 5% 50V
C3427	2113741F33	2.2nF 50V
C3428	2113741F33	2.2nF 50V
C3431	2111078B34	HQ 47pF 5%
C3433	2111078B36	HQ 56pF 5%
C3434	2113741A45	10nF 50V
C3435	2113740A67	330pF 5% 50V
C3436	2311049A45	TANT CP 10uF 10% 35V
C3437	2113741A57	33nF 50V
C3438	2111078B59	HQ 470pF 5%
C3439	2111078B59	HQ 470pF 5%
C3440	2113741F25	1nF 50V
C3441	2111078B47	HQ 150pF 5%
C3442	2111078B47	HQ 150pF 5%
C3444	2111078B36	HQ 56pF 5%
C3445	2111078B23	HQ 24pF 5%
C3446	2111078B37	HQ 62pF 5%
C3447	2111078B19	HQ 16pF 5%
C3450	2113740F67	470pF 5% 50V
C3451	2113741F25	1nF 50V
C3452	2113740F29	12pF 5% 50V
C3453	2113740F67	470pF 5% 50V
C3471	2113743E07	22nF 16V
C3472	2111078B53	HQ 270pF 5%
C3473	2111078B53	HQ 270pF 5%
C3474	2113740F59	220pF 5% 50V
C3475	2113740F23	6.8pF 5% 50V
C3491	2111078B18	HQ 15pF 5%
C3492	2111078B38	HQ 68pF 5%
C3493	2111078B08	HQ 6.2pF 5%
C3494	2111078B16	HQ 13pF 5%
C3495	2111078B01	HQ 3.3pF 5%
C3496	2111078B31	HQ 36pF 5%
C3498	2111078B16	HQ 13pF 5%
C3499	2111078B19	HQ 16pF 5%
C3501	2113741F33	2.2nF 50V
C3502	2113741F33	2.2nF 50V
C3503	2113740F67	470pF 5% 50V
C3504	2113741F49	10nF 50V
C3505	2311049A07	TANT CP 1uF 10% 16V
C3506	2113741F33	2.2nF 50V X7R
C3507	2113740F51	100pF 5% 50V
C3508	2113740F67	470pF 5% 50V
C3510	2113740F67	470pF 5% 50V
D3000	4813833C02	DUAL SOT MMBD6100
D3001	4805649Q13	VCTR 1SV228 SOT23
D3003	4880154K03	DUAL SCHOTTKY SOT23
D3004	4805649Q13	VCTR 1SV228 SOT23

Circuit Ref	Motorola Part No.	Description
D3011	4880142L01	PIN
D3031	4886143B01	MIXER DIODE CROSSOVER
D3101	4880154K03	DIODE DUAL SCHOTTKY
D3201	4802233J09	TRIPLE SOT143-RH
D3221	4880236E05	CHIP SCHOTTKY
D3341	4805649Q13	VCTR 1SV228 SOT23
D3361	4805649Q13	VCTR 1SV228 SOT23
D3362	4862824C01	VARACTOR CHIP
D3401	4813833C02	DUAL SOT MMBD6100
D3451	4880236E05	CHIP SCHOTTKY
D3471	4802482J02	PIN MA/COM
D3472	4802482J02	PIN MA/COM
FL3101	9180112R16	44.85 MHZ CRYSTAL FLTR 80dB
FL3102	9180112R16	44.85 MHZ CRYSTAL FLTR 80dB
FL3111	9180469V03	CER FLTR 6EL 455 KHZ SMD
FL3112	9180469V06	CER FLTR 6EL 455 KHZ SMD
FL3113	9180468V04	CER FLTR 4EL 455 KHZ SMD
FL3114	9180468V06	CER FLTR 4EL 455 KHZ SMD
J3401	0986166B02	RF CONN MINI UHF
L3002	2462587T23	COIL CHIP 470nH
L3031	2462587T24	COIL CHIP 560nH
L3032	2462587T17	COIL CHIP 150nH
L3101	2462587T25	COIL CHIP 620nH
L3111	2462587T25	COIL CHIP 620nH
L3112	2462587T25	COIL CHIP 620nH
L3124	2462587N68	1uH
L3201	2462587Q42	IND CHIP 390nH 10%
L3231	2462587Q20	IND CHIP 2.2uH 20%
L3301	2462587N44	CHIP IND 18 NH 5%
L3302	2462587N53	CHIP IND 100 nH 5%
L3317	2462587V28	CHIP IND 33 NH 5%
L3318	2462587V34	IND CHIP 100nH 5%
L3331	2462587V32	CHIP IND 68NH 5%
L3332	2462587V15	IND CHIP 100nH 10%
L3333	2462587Q47	IND CHIP 1uH 10%
L3341	2484562T13	MINI-SPRING AW IND 8NH 2%
L3343	2462587N56	COIL CHIP 180nH 5%
L3344	2462587N68	CHIP IND 1 uH 5%
L3345	2462587N68	CHIP IND 1 uH 5%
L3346	2484562T18	MINI-SPRING AW IND 35.5NH 2%
L3351	2462587N68	CHIP IND 1 uH 5%
L3361	2462587N50	CHIP IND 56 nH 5%
L3362	2462587N51	CHIP IND 68 nH 5%
L3363	2462587N50	CHIP IND 56 nH 5%
L3364	2462587N68	CHIP IND 1 uH 5%
L3401	2460591A01	SQUARE COIL 4.22nH 3T
L3402	2484657R01	Ferrite Bead

Circuit Ref	Motorola Part No.	Description
L3403	2462587T13	COIL CHIP 68nH
L3411	2462587T13	COIL CHIP 68nH
L3412	2462587X42	IND CHIP LO-PRO 12nH 5%
L3414	2460591A11	SQUARE COIL 7.66nH 3T
L3421	2484657R01	Ferrite Bead
L3422	2460591C23	SQUARE COIL 16nH 3T
L3436	2484657R01	Ferrite Bead
L3437	2460592A01	COIL AW 17nH 2T
L3443	2460591X02	COIL SQUARE 25nH
L3471	2462587X69	IND CHIP 1.2uH 5%
L3472	2460592B01	COIL AW 51nH 4T
L3491	2460592B01	COIL AW 51nH 4T
L3492	2460592B01	COIL AW 51nH 4T
L3493	2460592B01	COIL AW 51nH 4T
M3421	2686201B01	HEAT SPREADER
Q3001	4813827A07	TSTR NPN SML SIG MMBR9
Q3002	4813824A17	TSTR PNP 40V .2A B=100-
Q3021	4805921T02	TSTR DUAL ROHM FMC2
Q3101	4813827A07	TSTR NPN SML SIG MMBR9
Q3102	4813827A07	TSTR NPN SML SIG MMBR9
Q3141	4813824A10	TSTR NPN 40V .2A B=50-150
Q3151	4880048M01	TSTR NPN DIG 47k/47k
Q3152	4880048M01	TSTR NPN DIG 47k/47k
Q3221	4880048M01	TSTR NPN DIG 47k/47k
Q3301	4813827A07	TSTR NPN SML SIG MMBR9
Q3303	4802245J50	TSTR DUAL NPN/PNP UMC5N
Q3304	4805218N63	RF TRANS SOT 323 BFG67W
Q3411	4805921T02	DUAL ROHM FMC2 RH
Q3421	4886212B01	LD MOS PWR TSTR MRF1518
Q3422	4880048M01	NPN DIG 47k/47k
Q3441	4886136B01	LD MOS PWR TSTR MRF1565 MRF1550
Q3442	4880048M01	NPN DIG 47k/47k
Q3471	4880048M01	NPN DIG 47k/47k
Q3472	4805128M27	PNP SOT89 BSR33 LH
R3000	0662057A53	1k5 1/16W 5%
R3001	0662057A97	100k 1/16W
R3002	0662057A43	560 1/16W 5%
R3003	0662057A49	1k 1/16W 5%
R3004	0662057A53	1k5 1/16W 5%
R3006	0662057A73	10k 1/16W 5%
R3009	0662057A97	100k 1/16W
R3010	0662057A45	680 OHMS 5%
R3011	0662057A65	4k7 1/16W 5%
R3012	0662057A49	1k 1/16W 5%
R3013	0662057A61	3k3 1/16W 5%
R3014	0662057A18	51 1/16W 5%
R3015	0662057A01	10 1/16W 5%
R3016	0662057A01	10 1/16W 5%

Circuit Ref	Motorola Part No.	Description
R3018	0662057A33	220 1/16W 5%
R3019	0662057A89	47k 1/16W 5%
R3021	0662057A43	560 1/16W 5%
R3024	0662057A39	390 1/16W 5%
R3025	0662057A53	1k5 1/16W 5%
R3026	0662057A73	10k 1/16W 5%
R3027	0662057A73	10k 1/16W 5%
R3028	0662057A39	390 1/16W 5%
R3031	0662057A18	51 1/16W 5%
R3033	0662057B47	0 1/16W
R3101	0662057A75	12k 1/16W 5%
R3102	0662057A01	10 1/16W 5%
R3105	0662057A25	100 1/16W 5%
R3106	0662057A83	27k 1/16W 5%
R3107	0662057A69	6k8 1/16W 5%
R3108	0662057A44	620 OHMS 5%
R3111	0662057A75	12k 1/16W 5%
R3112	0662057A01	10 1/16W 5%
R3113	0662057A37	330 1/16W 5%
R3115	0662057A39	390 1/16W 5%
R3116	0662057A37	330 1/16W 5%
R3117	0662057A83	27k 1/16W 5%
R3118	0662057A69	6k8 1/16W 5%
R3123	0662057B47	0 1/16W
R3124	0662057A47	820 1/16W
R3130	0662057A18	51 1/16W 5%
R3132	0662057A77	15k 1/16W 5%
R3133	0662057A71	8k2 1/16W 5%
R3134	0662057A73	10k 1/16W 5%
R3135	0662057A51	1k2 1/16W 5%
R3141	0662057A39	390 1/16W 5%
R3142	0662057A55	1k8 1/16W 5%
R3144	0662057A58	2k4 1/16W 5%
R3145	0662057A61	3k3 1/16W 5%
R3146	0662057A45	680 OHMS 5%
R3147	0662057A75	12k 1/16W 5%
R3151	0662057A73	10k 1/16W 5%
R3152	0662057A73	10k 1/16W 5%
R3153	0662057A73	10k 1/16W 5%
R3154	0662057A73	10k 1/16W 5%
R3201	0662057A17	47 1/16W 5%
R3202	0662057B46	10MEG
R3203	0662057A17	47 1/16W 5%
R3204	0662057A17	47 1/16W 5%
R3206	0662057B02	150k 1/16W
R3211	0662057B47	0 1/16W
R3221	0662057A39	390 1/16W 5%
R3222	0662057A45	680 OHMS 5%
R3223	0662057A25	100 1/16W 5%
R3224	0662057A89	47k 1/16W 5%
R3225	0662057A89	47k 1/16W 5%

Circuit Ref	Motorola Part No.	Description
R3227	0662057A97	100k 1/16W
R3241	0662057A25	100 1/16W 5%
R3242	0662057B47	0 1/16W
R3251	0662057B04	180k 1/16W 5%
R3252	0662057B10	330k 1/16W 5%
R3261	0662057A89	47k 1/16W 5%
R3263	0662057A65	4k7 1/16W 5%
R3301	0662057A22	75 1/16W 5%
R3302	0662057A25	100 1/16W 5%
R3303	0662057A57	2k2 1/16W 5%
R3304	0662057A49	1k 1/16W 5%
R3308	0662057B47	0 1/16W
R3311	0662057A25	100 1/16W 5%
R3316	0662057B47	0 1/16W
R3318	0662057A09	22 1/16W 5%
R3321	0662057A73	10k 1/16W 5%
R3323	0662057A49	1k 1/16W 5%
R3331	0662057A17	47 1/16W 5%
R3335	0662057A13	33 1/16W 5%
R3336	0662057A77	15k 1/16W 5%
R3341	0662057A33	220 1/16W 5%
R3342	0662057A15	39 1/16W 5%
R3343	0662057A25	100 1/16W 5%
R3351	0662057A80	20k 1/16W 5%
R3352	0662057A75	12k 1/16W 5%
R3353	0662057A97	100k 1/16W
R3354	0662057B02	150k 1/16W
R3355	0662057A80	20k 1/16W 5%
R3356	0662057A75	12k 1/16W 5%
R3361	0662057A33	220 1/16W 5%
R3362	0662057A17	47 1/16W 5%
R3364	0662057A89	47k 1/16W 5%
R3400	0662057A41	470 1/16W 5%
R3401	0662057A36	300 1/16W 5%
R3402	0662057A05	15 1/16W 5%
R3403	0662057A36	300 1/16W 5%
R3404	0662057A89	47k 1/16W 5%
R3405	0662057A25	100 1/16W 5%
R3406	0662057A97	100k 1/16W
R3412	0662057A67	5k6 1/16W 5%
R3413	0662057A61	3k3 1/16W 5%
R3414	0683962T51	120 1W 5%
R3415	0662057A14	36 1/16W 5%
R3416	0662057A14	36 1/16W 5%
R3418	0662057A81	22k 1/16W 5%
R3421	0662057A87	39k 1/16W 5%
R3422	0662057A57	2k2 1/16W 5%
R3423	0662057A87	39k 1/16W 5%
R3424	0662057C13	2R7 1/10W 5%
R3425	0662057C13	2R7 1/10W 5%
R3426	0662057C13	2R7 1/10W 5%

Circuit Ref	Motorola Part No.	Description
R3427	0662057C13	2R7 1/10W 5%
R3428	0662057A58	2k4 1/16W 5%
R3429	0662057A33	220 1/16W 5%
R3431	0680194M18	51 1W 5%
R3432	0680194M18	51 1W 5%
R3433	0662057C13	2R7 1/10W 5%
R3434	0662057C13	2R7 1/10W 5%
R3435	0662057C13	2R7 1/10W 5%
R3441	0662057A87	39k 1/16W 5%
R3442	0662057A57	2k2 1/16W 5%
R3443	0662057A87	39k 1/16W 5%
R3444	0662057C19	4R7 1/10W 5%
R3445	0662057A58	2k4 1/16W 5%
R3446	0662057B47	0 1/16W
R3450	0662057A41	470 1/16W 5%
R3452	0662057A75	12k 1/16W 5%
R3454	0662057A84	30k 1/16W 5%
R3455	0662057A97	100k 1/16W
R3457	0683962T51	120 1W 5%
R3471	0662057A41	470 1/16W 5%
R3473	0680194M18	51 1W 5%
R3474	0680194M18	51 1W 5%
R3475	0662057A73	10k 1/16W 5%
R3491	0662057A73	10k 1/16W 5%
R3501	0662057A69	6k8 1/16W 5%
R3502	0662057A87	39k 1/16W 5%
R3504	0662057A73	10k 1/16W 5%
R3505	0662057B09	300k 1/16W 5%
R3507	0662057A80	20k 1/16W 5%
R3508	0662057A97	100k 1/16W
R3509	0662057A49	1k 1/16W 5%
T3001	2508396X02	TRANSFORMER
T3002	2508397X02	TRANSFORMER
U3101	5186144B01	FM IF IC SA616
U3111	5113805A86	IC QUAD ANALOG MUX/ DEMUX
U3115	5113805A86	IC QUAD ANALOG MUX/ DEMUX
U3201	5185963A27	IC TESTED AT25016 48 PIN GFP
U3211	5105739X05	IC SOT 5V HI-PRECISION REGULAT
U3301	5105750U54	VCO BUFFER PKG DIE
U3401	5185130C65	LDMOS DRIVER VHF/UHF/ 800MHz
U3402	5180932W01	LINEAR IC OP AMP
U3501	5185765B01	IC POWER CONTROL
U3502	5185963A15	TEMP SENSOR 1M5
VR3471	4813830A15	5.6V 5% 225mW
Y3101	4880606B09	CRYSTAL 44.395 MHZ

Circuit Ref	Motorola Part No.	Description
Y3102	9186145B02	CERAMIC DISCRIMINATOR 455kHz
Y3263	4886182B01	VCTCXO 16.8MHz 2ppm TTSO5V
* Y3261	Not Used	16.8MHz 75Z04

* Motorola Depot Servicing only

Reference designators with an asterisk indicate components which are not fieldreplaceable because they need to be calibrated with specialized factory equipment after installation. Radios in which these parts have been replaced in the field will be off frequency at temperature extremes.

6.0 VHF 25-45W PCB 8486140B12 / Schematic

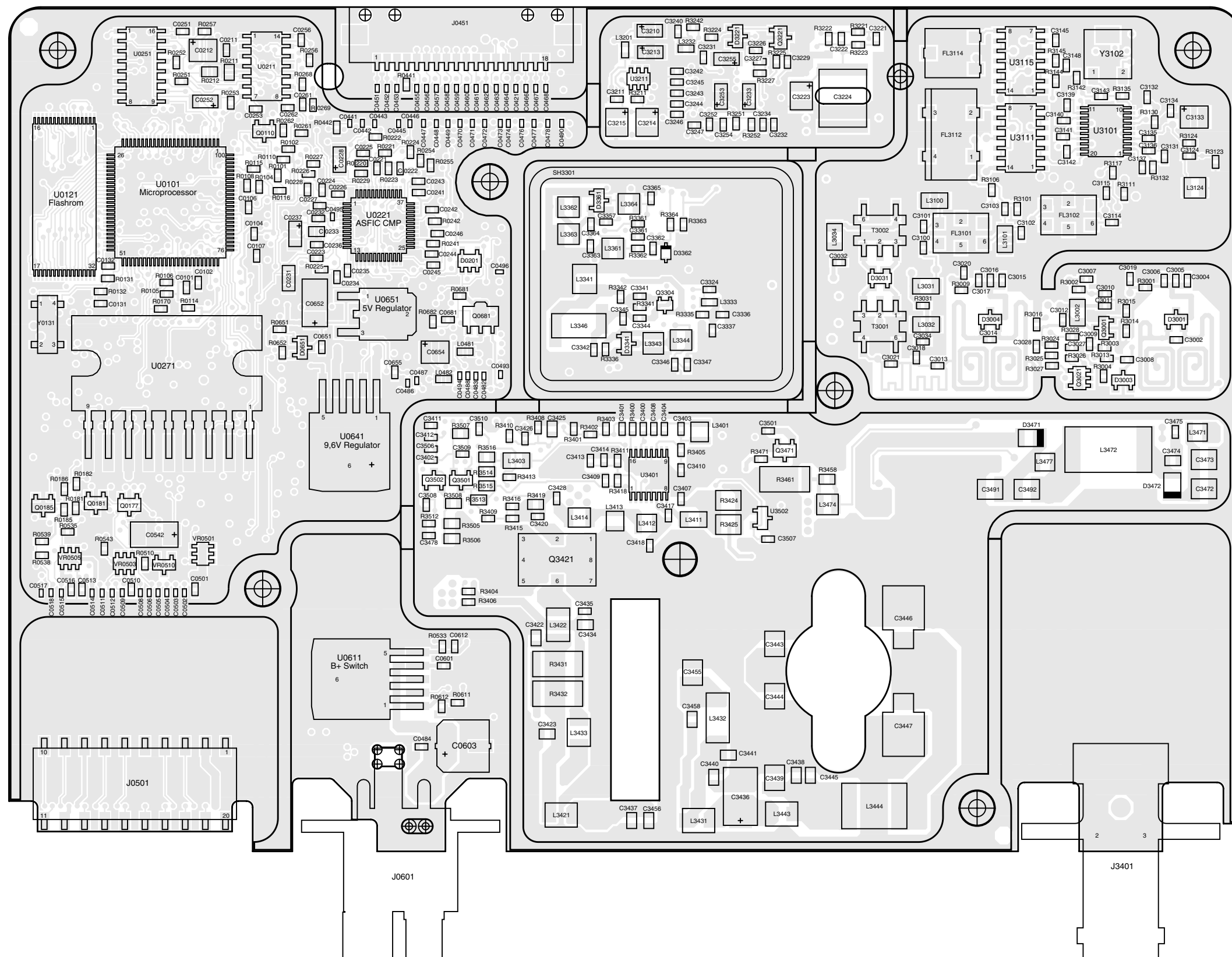

ZWG0130227-B

**VHF (136-174 MHz) 25-45W
8486140B12 Top Side**

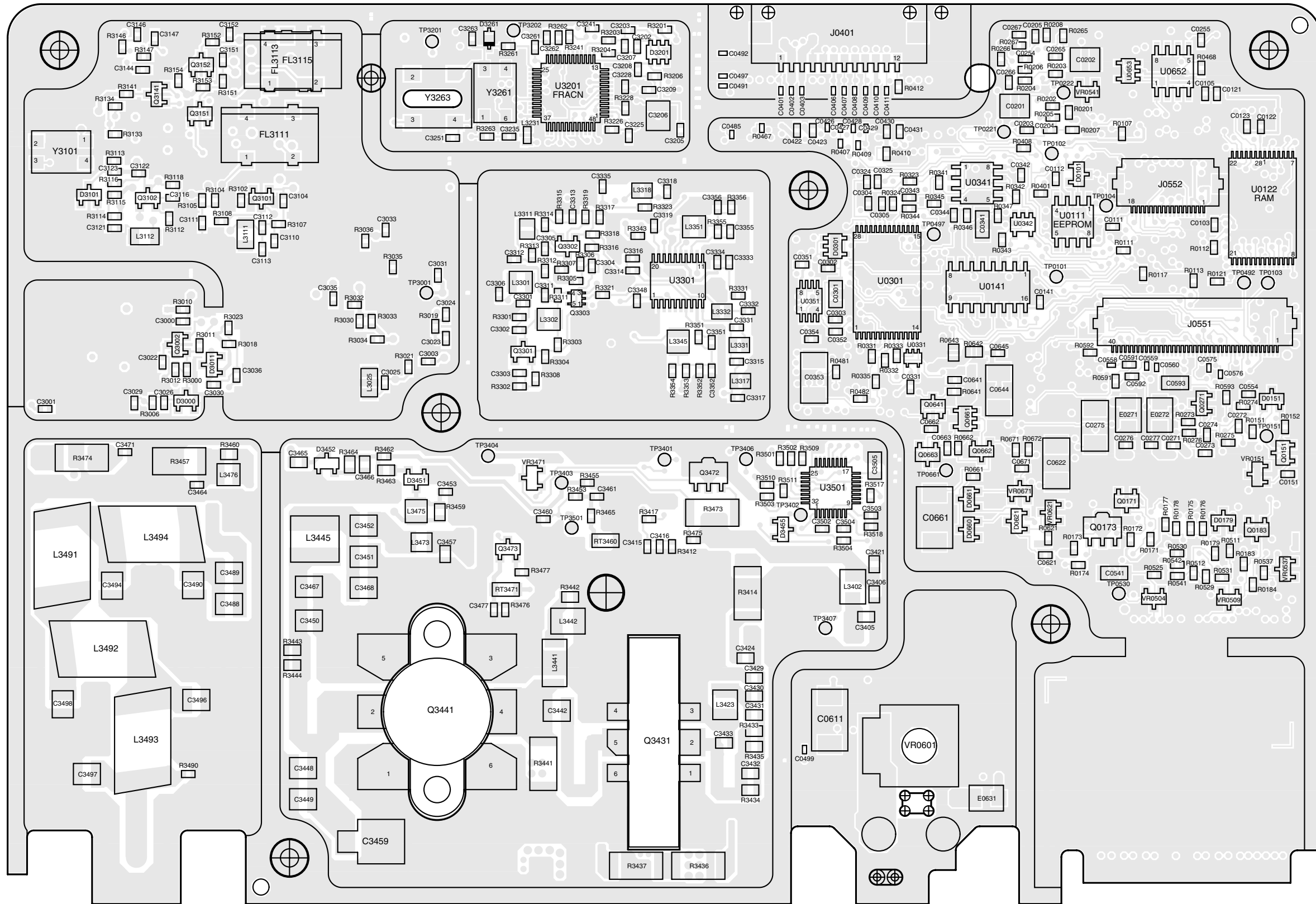

ZWG0130226-B

VHF (136-174 MHz) 25-45W 846140B12 Bottom Side

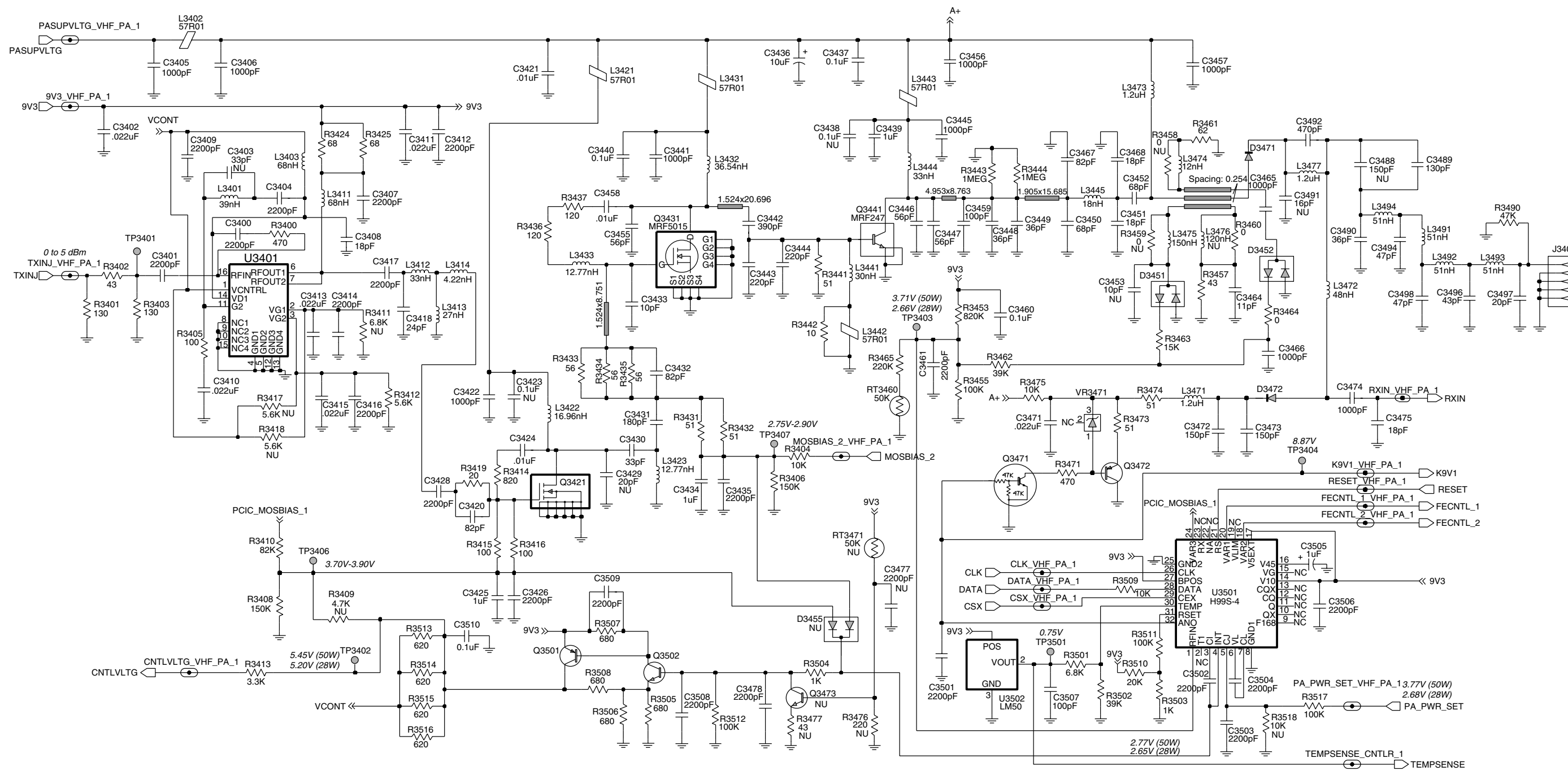

ZWG0130512-O

VHF (136-174 MHz) Power Amplifier 25-45W

6.1 VHF PCB 8486140B12 25-45W Parts List

Circuit Ref	Motorola Part No	Description
C3000	2113741F37	3.3nF 50V
C3001	2113740F19	4.7pF 5%
C3002	2113740F26	9.1pF 5%
C3003	2113741F37	3.3nF 50V
C3004	2113740F45	56pF 5%
C3005	2113740F51	100pF 5%
C3006	2113740F45	56pF 5%
C3007	2113741F37	3.3nF 50V
C3008	2113741F25	1nF 50V
C3009	2113741F13	330pF 50V
C3010	2113741F13	330pF 50V
C3011	2113741F37	3.3nF 50V
C3012	2113741F25	1nF 50V
C3013	2113740F45	56pF 5%
C3014	2113740F24	7.5pF 5%
C3015	2113740F45	56pF 5%
C3016	2113740F51	100pF 5% 50V
C3017	2113740F42	43pF 5% 50V
C3019	2113741F25	1nF 50V
C3020	2113741F25	1nF 50V
C3021	2113740F53	120pF 5% 50V
C3022	2113741F49	10nF 50V
C3026	2113743E20	100nF 16V
C3027	2113741F49	10nF 50V
C3028	2113741F49	10nF 50V
C3030	2113741F25	1nF 50V
C3033	2113740F20	5.1pF 5% 50V
C3034	2113740F49	82pF 5% 50V
C3035	2113740F33	18pF 5% 50V
C3036	2113741F25	1nF 50V
C3100	2113741F25	1nF 50V
C3102	2113740F31	15pF 5% 50V
C3103	2113740F39	33pF 5% 50V
C3104	2113743E20	100nF 16V
C3110	2113740F37	27pF 5% 50V
C3111	2113743E20	100nF 16V
C3112	2113740F49	82pF 5% 50V
C3114	2113740F33	18pF 5% 50V
C3115	2113740F35	22pF 5% 50V
C3116	2113743E20	100nF 16V
C3121	2113743E20	100nF 16V
C3122	2113743E11	39nF 10%
C3123	2113743E11	39nF 10%
C3132	2113743E20	100nF 16V
C3133	2311049A57	TANT CP 10uF 10% 16V
C3134	2113743E20	100nF 16V
C3135	2113740L30	33pF 2%
C3136	2113740L29	30pF 2%
C3137	2113743E11	39nF 10%
C3139	2113743E20	100nF 16V
C3140	2113743E20	100nF 16V
C3141	2113743E20	100nF 16V
C3142	2113743E20	100nF 16V
C3143	2113740F53	120pF 5% 50V
C3144	2113743E20	100nF 16V

Circuit Ref	Motorola Part No	Description
C3145	2113743E20	100nF 16V
C3146	2113741F41	4.7nF 50V
C3147	2113743E20	100nF 16V
C3151	2113741F49	10nF 50V
C3152	2113741F49	10nF 50V
C3202	2113741F49	10nF 50V
C3203	2113741F49	10nF 50V
C3205	2113741F49	10nF 50V
C3206	2311049A57	TANT CP 10uF 10% 16V
C3208	2113743E20	100nF 16V
C3209	2113743E20	100nF 16V
C3210	2311049A40	TANT CP 2.2uF 10% 10V
C3211	2113743E20	100nF 16V
C3213	2311049A40	TANT CP 2.2uF 10% 10V
C3214	2311049A09	TANT CP 2.2uF 10% 20V
C3215	2311049A09	TANT CP 2.2uF 10% 20V
C3221	2113743E20	100nF 16V
C3222	2113743E20	100nF 16V
C3224	0882422W23	FILM SM 1.0uF 15V 5%
C3225	2113743E20	100nF 16V
C3226	2113740F25	8.2pF 5% 50V
C3227	2113740F51	100pF 5% 50V
C3228	2113743E20	100nF 16V
C3229	2113743E12	47nF 10%
C3231	2113741F49	10nF 50V
C3232	2113741F49	10nF 50V
C3233	2311049A40	TANT CP 2.2uF 10%
C3234	2113741F49	10nF 50V
C3235	2113741F49	10nF 50V
C3242	2113740F59	220pF 5% 50V
C3243	2113740F59	220pF 5% 50V
C3244	2113740F59	220pF 5% 50V
C3245	2113740F59	220pF 5% 50V
C3246	2113740F59	220pF 5% 50V
C3247	2113740F27	10pF 5% 50V
C3251	2113743E20	100nF 16V
C3252	2113741F25	1nF 50V
C3253	2311049A56	TANT CP 4.7uF 20% 10V
C3254	2113743E20	100nF 16V
C3255	2311049A40	TANT CP 2.2uF 10% 10V
C3263	2113743E20	100nF 16V
C3302	2113740F23	6.8pF 5% 50V
C3303	2113741F49	10nF 50V
C3306	2113740F20	5.1pF 5% 50V
C3311	2113743E07	22nF 16V
C3314	2113740F23	6.8pF 5% 50V
C3315	2113740F31	15pF 5% 50V
C3316	2113740F15	3.3pF 5% 50V
C3317	2113740F39	33pF 5% 50V
C3318	2113740F21	5.6pF 5% 50V
C3319	2113741F25	1nF 50V
C3324	2113741F49	10nF 50V
C3332	2113743E20	100nF 16V
C3333	2113743E20	100nF 16V
C3334	2113743E07	22nF 16V
C3335	2113741F49	10nF 50V

Circuit Ref	Motorola Part No	Description
C3336	2113741F49	10nF 50V
C3337	2113743E20	100nF 16V
C3341	2113741F25	1nF 50V
C3342	2113740L05	3.0pF +-0.1pF
C3344	2113740F09	1.8pF 5% 50V
C3345	2113740L25	20pF +-0.25pF
C3346	2113741F49	10nF 50V
C3347	2113741F49	10nF 50V
C3348	2113741F49	10nF 50V
C3351	2113741F49	10nF 50V
C3352	2113743E07	22nF 16V
C3355	2113741F49	10nF 50V
C3356	2113743E07	22nF 16V
C3357	2113740F24	7.5pF 5% 50V
C3361	2113741F25	1nF 50V
C3362	2113740F21	5.6pF 5% 50V
C3363	2113740F47	68pF 5% 50V
C3364	2113740F31	15pF 5% 50V
C3365	2113741F25	1nF 50V
C3400	2113741F33	2.2nF 50V
C3401	2113741F33	2.2nF 50V
C3402	2113743E07	22nF 16V
C3404	2113741F33	2.2nF 50V
C3405	2113740A79	1nF 5% 50V
C3406	2113740A79	1nF 5% 50V
C3407	2113741F33	2.2nF 50V
C3408	2113740F33	18pF 5% 50V
C3409	2113741F33	2.2nF 50V
C3410	2113743E07	22nF 16V
C3411	2113743E07	22nF 16V
C3412	2113741F33	2.2nF 50V
C3413	2113743E07	22nF 16V
C3414	2113741F33	2.2nF 50V
C3415	2113743E07	22nF 16V
C3416	2113741F33	2.2nF 50V
C3417	2113741F33	2.2nF 50V
C3418	2113740F36	24pF 5% 50V
C3420	2113740F49	82pF 5% 50V
C3421	2113741A45	10nF 50V
C3422	2113740A79	1nF 5% 50V
C3424	2113741A45	10nF 50V
C3425	2113928E01	1uF 10% 10V
C3426	2113741F33	2.2nF 50V
C3428	2113741F33	2.2nF 50V
C3430	2113740A41	33pF 5% 50V
C3431	2113740A61	180pF 5% 50V
C3432	2113740A53	82pF 5% 50V
C3433	2113740A29	10pF 5% 50V
C3434	2113928E01	1uF 10% 10V
C3435	2113741F33	2.2nF 50V
C3436	2311049A45	TANT CP 10uF 10% 35V
C3437	2113741M69	0.1uF 50V
C3439	2113741W01	1uF 10% 25V
C3440	2113741M69	0.1uF 50V
C3441	2113740A79	1nF 5% 50V
C3442	2111078B57	HQ 390pF 5%

Circuit Ref	Motorola Part No	Description
C3443	2111078B51	RF 220 5 NPO 100V
C3444	2111078B51	RF 220 5 NPO 100V
C3445	2113740A79	1nF 5% 50V
C3446	2180464E50	56pF 5% 250V
C3447	2180464E50	56pF 5% 250V
C3448	2111078B31	HQ 36pF 5%
C3449	2111078B31	HQ 36pF 5%
C3450	2111078B38	HQ 68pF 5%
C3451	2111078B20	HQ 18pF 5%
C3452	2111078B38	HQ 68pF 5%
C3455	2111078B36	HQ 56pF 5%
C3456	2113740A79	1nF 5% 50V
C3457	2113740A79	1nF 5% 50V
C3458	2113741A45	10nF 50V
C3459	2180464E16	100pF 5% 250V
C3460	2113743E20	100nF 16V
C3461	2113741F33	2.2nF 50V
C3464	2113740F28	11pF 5% 50V
C3465	2113740A79	1nF 5% 50V
C3466	2113740A79	1nF 5% 50V
C3467	2111078B40	HQ 82pF 5%
C3468	2111078B20	HQ 18pF 5%
C3471	2113743E07	22nF 16V
C3472	2111078B47	HQ 150pF 5%
C3473	2111078B47	HQ 150pF 5%
C3474	2113740A79	1nF 5% 50V
C3475	2113740F33	18pF 5% 50V
C3478	2113741F33	2.2nF 50V
C3489	2111078B45	HQ 130pF 5%
C3490	2111078B31	HQ 36pF 5%
C3492	2111078B59	HQ 470pF 5%
C3494	2111078B34	HQ 47pF 5%
C3496	2111078B33	HQ 43pF 5%
C3497	2111078B21	HQ 20pF 5%
C3498	2111078B34	HQ 47pF 5%
C3501	2113741F33	2.2nF 50V
C3502	2113741F33	2.2nF 50V
C3503	2113741F33	2.2nF 50V
C3504	2113741F33	2.2nF 50V
C3505	2311049A07	TANT CP 1uF 10% 16V
C3506	2113741F33	2.2nF 50V
C3507	2113740F51	100pF 5% 50V
C3508	2113741F33	2.2nF 50V
C3509	2113741F33	2.2nF 50V
C3510	2113743E20	100nF 16V
D3000	4813833C02	DUAL SOT MMBD6100
D3001	4805649Q13	VCTR 1SV228 SOT23
D3003	4880154K03	DUAL SCHOTTKY SOT23
D3004	4805649Q13	VCTR 1SV228 SOT23
D3011	4880142L01	PIN
D3031	4886143B01	MIXER DIODE CROSSOVER
D3101	4880154K03	DIODE DUAL SCHOTTKY
D3201	4802233J09	TRIPLE SOT143-RH
D3221	4880236E05	CHIP SCHOTTKY
D3341	4805649Q13	VCTR 1SV228 SOT23
D3361	4805649Q13	VCTR 1SV228 SOT23

Circuit Ref	Motorola Part No	Description
D3362	4862824C01	VARACTOR CHIP
D3451	4882290T02	HOT CARRIER HSMS2802
D3452	4882290T02	HOT CARRIER HSMS2802
D3471	4802482J02	PIN MA/COM
D3472	4802482J02	PIN MA/COM
FL3101	9180112R16	44.85 MHZ XSTAL FLTR 80dB
FL3102	9180112R16	44.85 MHZ XSTAL FLTR 80dB
FL3111	9180469V03	CER FLTR 6EL 455 KHZ SMD
FL3112	9180469V06	CER FLTR 6EL 455 KHZ SMD
FL3113	9180468V04	CER FLTR 4EL 455 KHZ SMD
FL3114	9180468V06	CER FLTR 4EL 455 KHZ SMD
J3401	0986166B02	RF CONN MINI UHF
L3002	2462587T23	COIL CHIP 470nH
L3031	2462587T24	COIL CHIP 560nH
L3032	2462587T17	COIL CHIP 150nH
L3101	2462587T25	COIL CHIP 620nH
L3111	2462587T25	COIL CHIP 620nH
L3112	2462587T25	COIL CHIP 620nH
L3201	2462587Q42	IND CHIP 390nH 10%
L3231	2462587Q20	IND CHIP 2.2uH 20%
L3301	2462587N44	CHIP IND 18 NH 5%
L3302	2462587N53	CHIP IND 100 nH 5%
L3317	2462587V28	CHIP IND 33 NH 5%
L3318	2462587V34	IND CHIP 100nH 5%
L3331	2462587V32	CHIP IND 68NH 5%
L3332	2462587V15	IND CHIP 100nH 10%
L3333	2462587Q47	IND CHIP 1uH 10%
L3341	2484562T13	MINI-SPRING AW IND 8NH 2%
L3343	2462587N56	COIL CHIP 180nH 5%
L3344	2462587N68	CHIP IND 1 uH 5%
L3345	2462587N68	CHIP IND 1 uH 5%
L3346	2484562T18	MINI-SPRING AW IND 35.5NH 2%
L3351	2462587N68	CHIP IND 1 uH 5%
L3361	2462587N50	CHIP IND 56 nH 5%
L3362	2462587N51	CHIP IND 68 nH 5%
L3363	2462587N50	CHIP IND 56 nH 5%
L3364	2462587N68	CHIP IND 1 uH 5%
L3401	2462587X48	IND CHIP LO-PRO 39nH 5%
L3402	2484657R01	Ferrite Bead
L3403	2462587T13	COIL CHIP 68nH
L3411	2462587T13	COIL CHIP 68nH
L3412	2462587X47	IND CHIP LO-PRO 33.0 N
L3413	2462587X46	IND CHIP LO-PRO 27.0 N
L3414	2460591A01	SQUARE COIL 4.22nH 3T
L3421	2484657R01	Ferrite Bead
L3422	2460591C73	COIL AIRW 16.96nH 10% 5TNS
L3423	2460591B73	SQUARE COIL 12.77nH 10%
L3431	2484657R01	Ferrite Bead
L3432	2460591F77	SQUARE COIL 35.5nH 10% 8T AWG22 U
L3433	2460591B73	SQUARE COIL 12.77nH 10%
L3441	2460591E77	SQUARE COIL 30nH 10% 7T
L3442	2484657R01	Ferrite Bead

Circuit Ref	Motorola Part No	Description
L3443	2484657R01	Ferrite Bead
L3444	2460591X03	COIL SQUARE 5 TNS
L3445	2460591X01	COIL SQUARE
L3471	2462587X69	IND CHIP 1.2uH 5%
L3472	2460591X05	COIL SQUARE 48nH 10% 7TNS
L3473	2462587X69	IND CHIP 1.2uH 5%
L3474	2462587N42	CHIP IND 12nH 5%
L3475	2462587N55	CHIP IND 150nH 5%
L3477	2462587X69	IND CHIP 1.2uH 5%
L3491	2460592B01	COIL AW 51nH 4T
L3492	2460592B01	COIL AW 51nH 4T
L3493	2460592B01	COIL AW 51nH 4T
L3494	2460592B01	COIL AW 51nH 4T
Q3001	4813827A07	NPN SML SIG MMBR9
Q3002	4813824A17	PNP 40V .2A B=100-
Q3021	4805921T02	DUAL ROHM FMC2
Q3101	4813827A07	NPN SML SIG MMBR9
Q3102	4813827A07	NPN SML SIG MMBR9
Q3141	4813824A10	NPN 40V .2A B=50-150
Q3151	4880048M01	NPN DIG 47k/47k
Q3152	4880048M01	NPN DIG 47k/47k
Q3221	4880048M01	NPN DIG 47k/47k
Q3301	4813827A07	NPN SML SIG MMBR9
Q3303	4802245J50	DUAL NPN/PNP UMC5N
Q3304	4805218N63	RF TRANS SOT 323 BFOQ67W
Q3421	5105385Y91	LD MOS PWR MODULE 16 CELL
Q3431	4805537W01	MRF5015 MOS1
Q3441	4884411L04	RF PWR TSTR MRF247 75W
Q3471	4880048M01	NPN DIG 47k/47k
Q3472	4805128M27	PNP SOT89 BSR33 LH
Q3501	4813824A17	PNP 40V .2A B=100-
Q3502	4813824A10	NPN 40V .2A B=50-150
R3000	0662057A53	1k5 1/16W 5%
R3001	0662057A97	100k 1/16W
R3002	0662057A43	560 1/16W 5%
R3003	0662057A49	1k 1/16W 5%
R3004	0662057A53	1k5 1/16W 5%
R3006	0662057A73	10k 1/16W 5%
R3009	0662057A97	100k 1/16W
R3010	0662057A45	680 OHMS 5%
R3011	0662057A65	4k7 1/16W 5%
R3012	0662057A49	1k 1/16W 5%
R3013	0662057A61	3k3 1/16W 5%
R3014	0662057A18	51 1/16W 5%
R3015	0662057A01	10 1/16W 5%
R3016	0662057A01	10 1/16W 5%
R3018	0662057A33	220 1/16W 5%
R3019	0662057A89	47k 1/16W 5%
R3021	0662057A43	560 1/16W 5%
R3024	0662057A39	390 1/16W 5%
R3025	0662057A53	1k5 1/16W 5%
R3026	0662057A73	10k 1/16W 5%
R3027	0662057A73	10k 1/16W 5%
R3028	0662057A39	390 1/16W 5%

Circuit Ref	Motorola Part No	Description
R3031	0662057A18	51 1/16W 5%
R3033	0662057B47	0 1/16W
R3101	0662057A75	12k 1/16W 5%
R3102	0662057A01	10 1/16W 5%
R3105	0662057A25	100 1/16W 5%
R3106	0662057A83	27k 1/16W 5%
R3107	0662057A69	6k8 1/16W 5%
R3108	0662057A44	620 OHMS 5%
R3111	0662057A75	12k 1/16W 5%
R3112	0662057A01	10 1/16W 5%
R3113	0662057A37	330 1/16W 5%
R3115	0662057A39	390 1/16W 5%
R3116	0662057A37	330 1/16W 5%
R3117	0662057A83	27k 1/16W 5%
R3118	0662057A69	6k8 1/16W 5%
R3130	0662057A18	51 1/16W 5%
R3132	0662057A77	15k 1/16W 5%
R3133	0662057A71	8k2 1/16W 5%
R3134	0662057A73	10k 1/16W 5%
R3135	0662057A51	1k2 1/16W 5%
R3141	0662057A39	390 1/16W 5%
R3142	0662057A55	1k8 1/16W 5%
R3144	0662057A58	2k4 1/16W 5%
R3145	0662057A61	3k3 1/16W 5%
R3146	0662057A45	680 OHMS 5%
R3147	0662057A75	12k 1/16W 5%
R3151	0662057A73	10k 1/16W 5%
R3152	0662057A73	10k 1/16W 5%
R3153	0662057A73	10k 1/16W 5%
R3154	0662057A73	10k 1/16W 5%
R3201	0662057A17	47 1/16W 5%
R3203	0662057A17	47 1/16W 5%
R3204	0662057A17	47 1/16W 5%
R3211	0662057B47	0 1/16W
R3221	0662057A39	390 1/16W 5%
R3222	0662057A45	CHIP RES 680 OHMS 5%
R3223	0662057A25	100 1/16W 5%
R3224	0662057A89	47k 1/16W 5%
R3225	0662057A89	47k 1/16W 5%
R3227	0662057A97	100k 1/16W
R3241	0662057A25	100 1/16W 5%
R3242	0662057B47	0 1/16W
R3251	0662057B04	180k 1/16W 5%
R3252	0662057B10	330k 1/16W 5%
R3261	0662057A89	47k 1/16W 5%
R3263	0662057A65	4k7 1/16W 5%
R3301	0662057A22	75 1/16W 5%
R3302	0662057A25	100 1/16W 5%
R3303	0662057A57	2k2 1/16W 5%
R3304	0662057A49	1k 1/16W 5%
R3308	0662057B47	0 1/16W
R3311	0662057A25	100 1/16W 5%
R3316	0662057B47	0 1/16W
R3318	0662057A09	22 1/16W 5%
R3321	0662057A73	10k 1/16W 5%
R3323	0662057A49	1k 1/16W 5%

Circuit Ref	Motorola Part No	Description
R3331	0662057A17	47 1/16W 5%
R3335	0662057A13	33 1/16W 5%
R3336	0662057A77	15k 1/16W 5%
R3341	0662057A33	220 1/16W 5%
R3342	0662057A15	39 1/16W 5%
R3343	0662057A25	100 1/16W 5%
R3351	0662057A80	20k 1/16W 5%
R3352	0662057A75	12k 1/16W 5%
R3353	0662057A97	100k 1/16W
R3354	0662057B02	150k 1/16W
R3355	0662057A80	20k 1/16W 5%
R3356	0662057A75	12k 1/16W 5%
R3361	0662057A33	220 1/16W 5%
R3362	0662057A17	47 1/16W 5%
R3364	0662057A89	47k 1/16W 5%
R3400	0662057A41	470 1/16W 5%
R3401	0662057A28	130 1/16W 5%
R3402	0662057A16	43 1/16W
R3403	0662057A28	130 1/16W
R3404	0662057A73	10k 1/16W
R3405	0662057A25	100 1/16W
R3406	0662057B02	150k 1/16W
R3408	0662057B02	150k 1/16W
R3410	0662057A95	82k 1/16W 5%
R3412	0662057A67	5k6 1/16W 5%
R3413	0662057A61	3k3 1/16W 5%
R3414	0683962T71	820 1W 5%
R3415	0662057A25	100 1/16W 5%
R3416	0662057A25	100 1/16W 5%
R3419	0662057C34	20 1/10W 5%
R3424	0662057K21	68 5% 1210
R3425	0662057K21	68 5% 1210
R3431	0680194M18	51 1W 5%
R3432	0680194M18	51 1W 5%
R3433	0662057C45	56 1/10W 5%
R3434	0662057C45	56 1/10W 5%
R3435	0662057C45	56 1/10W 5%
R3436	0683962T51	120 1W 5%
R3437	0683962T51	120 1W 5%
R3441	0680194M18	51 1W 5%
R3442	0662057C27	10R 1/10W 5%
R3443	0662057D48	1M 1/10W 5%
R3444	0662057D48	1M 1/10W 5%
R3453	0662057B20	820K 1/16W 5%
R3455	0662057A97	100k 1/16W
R3457	0680194M16	xx 1W 5%
R3460	0662057C01	0 1/10W 5%
R3461	0680194M20	62 1W 5%
R3462	0662057A87	39k 1/16W 5%
R3463	0662057D04	15kK 1/10W 5%
R3464	0662057C01	0 1/10W 5%
R3465	0662057B06	220k 1/16W
R3471	0662057A41	470 1/16W 5%
R3473	0680194M18	51 1W 5%
R3474	0680194M18	51 1W 5%
R3475	0662057A73	10k 1/16W 5%

Circuit Ref	Motorola Part No	Description
R3490	0662057A89	47k 1/16W 5%
R3501	0662057A69	6k8 1/16W 5%
R3502	0662057A87	39k 1/16W 5%
R3503	0662057A49	1k 1/16W 5%
R3504	0662057A49	1k 1/16W 5%
R3505	0662057C71	680 1/10W 5%
R3506	0662057C71	680 1/10W 5%
R3507	0662057C71	680 1/10W 5%
R3508	0662057C71	680 1/10W 5%
R3509	0662057A73	10k 1/16W 5%
R3510	0662057A80	20k 1/16W 5%
R3511	0662057A97	100k 1/16W
R3512	0662057A97	100k 1/16W
R3513	0611079A69	6k8 1/16W 5%
R3514	0611079A69	6k8 1/16W 5%
R3515	0611079A69	6k8 1/16W 5%
R3516	0611079A69	6k8 1/16W 5%
R3517	0662057A97	100k 1/16W
RT3460	0605621T02	THERMISTOR CHIP
T3001	2508396X02	TRANSFORMER
T3002	2508397X02	TRANSFORMER
U3101	5186144B01	FM IF IC SA616
U3111	5113805A86	IC QUAD ANALOG MUX/ DEMUX
U3115	5113805A86	IC QUAD ANALOG MUX/ DEMUX
U3201	5185963A27	IC TESTED AT25016 48 PIN GFP
U3211	5105739X05	IC SOT 5V HI-PRECISION REGULAT
U3301	5105750U54	VCO BUFFER PKG DIE
U3401	5105109Z67	LDMOS DRIVER VHF/UHF
U3501	5185765B01	IC POWER CONTROL
U3502	5185963A15	TEMP SENSOR 1M5
VR3471	4813830A15	5.6V 5% 225mW
Y3101	4880606B09	CRYSTAL 44.395 MHZ
Y3102	9186145B02	CERAMIC DISCRIMINATOR 455kHz
Y3263	4886182B01	VCTCXO 16.8MHz 2ppm TTSO5V
* Y3261	Not Used	16.8MHz 75Z04

* Motorola Depot Servicing only

Reference designators with an asterisk indicate components which are not fieldreplaceable because they need to be calibrated with specialized factory equipment after installation. Radios in which these parts have been replaced in the field will be off frequency at temperature extremes.

7.0 VHF 25-45W PCB 8486140B13

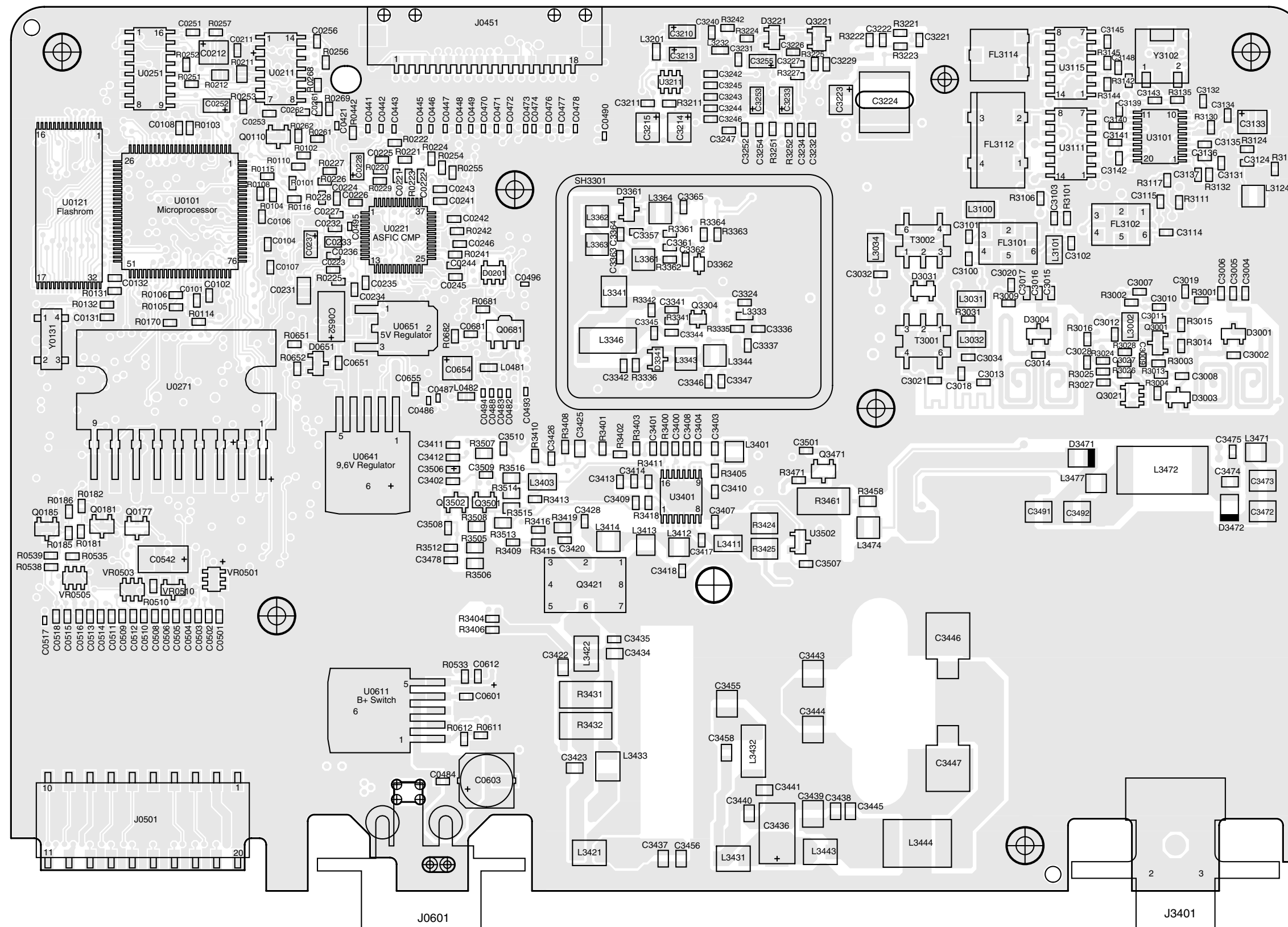

ZWG0130589-O

**VHF (136-174 MHz) 25-45W
8486140B12 Top Side**

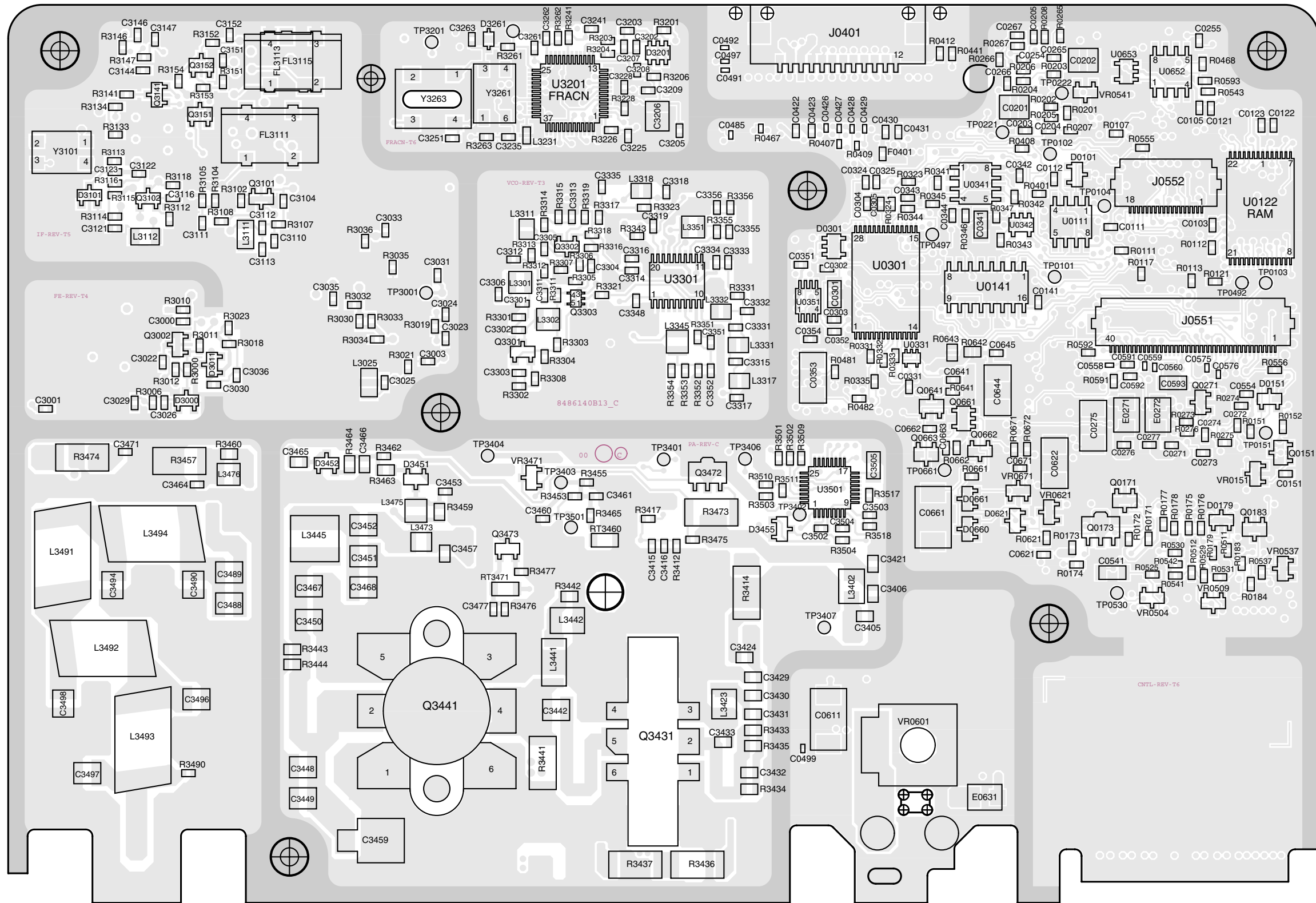

ZWG0130590-O

VHF (136-174 MHz) 25-45W 846140B12 Bottom Side

7.1 VHF PCB 8486140B12 25-45W Parts List

Circuit Ref	Motorola Part No	Description
C3000	2113741F37	3.3nF 50V
C3001	2113740F19	4.7pF 5%
C3002	2113740F26	9.1pF 5%
C3003	2113741F37	3.3nF 50V
C3004	2113740F45	56pF 5%
C3005	2113740F51	100pF 5%
C3006	2113740F45	56pF 5%
C3007	2113741F37	3.3nF 50V
C3008	2113741F25	1nF 50V
C3009	2113741F13	330pF 50V
C3010	2113741F13	330pF 50V
C3011	2113741F37	3.3nF 50V
C3012	2113741F25	1nF 50V
C3013	2113740F45	56pF 5%
C3014	2113740F24	7.5pF 5%
C3015	2113740F45	56pF 5%
C3016	2113740F51	100pF 5% 50V
C3017	2113740F42	43pF 5% 50V
C3019	2113741F25	1nF 50V
C3020	2113741F25	1nF 50V
C3021	2113740F53	120pF 5% 50V
C3022	2113741F49	10nF 50V
C3026	2113743E20	100nF 16V
C3027	2113741F49	10nF 50V
C3028	2113741F49	10nF 50V
C3030	2113741F25	1nF 50V
C3033	2113740F20	5.1pF 5% 50V
C3034	2113740F49	82pF 5% 50V
C3035	2113740F33	18pF 5% 50V
C3036	2113741F25	1nF 50V
C3100	2113741F25	1nF 50V
C3102	2113740F31	15pF 5% 50V
C3103	2113740F39	33pF 5% 50V
C3104	2113743E20	100nF 16V
C3110	2113740F37	27pF 5% 50V
C3111	2113743E20	100nF 16V
C3112	2113740F49	82pF 5% 50V
C3114	2113740F33	18pF 5% 50V
C3115	2113740F35	22pF 5% 50V
C3116	2113743E20	100nF 16V
C3121	2113743E20	100nF 16V
C3122	2113743E11	39nF 10%
C3123	2113743E11	39nF 10%
C3132	2113743E20	100nF 16V
C3133	2311049A57	TANT CP 10uF 10% 16V
C3134	2113743E20	100nF 16V
C3135	2113740L30	33pF 2%
C3136	2113740L29	30pF 2%
C3137	2113743E11	39nF 10%
C3139	2113743E20	100nF 16V
C3140	2113743E20	100nF 16V
C3141	2113743E20	100nF 16V
C3142	2113743E20	100nF 16V
C3143	2113740F53	120pF 5% 50V
C3144	2113743E20	100nF 16V

Circuit Ref	Motorola Part No	Description
C3145	2113743E20	100nF 16V
C3146	2113741F41	4.7nF 50V
C3147	2113743E20	100nF 16V
C3151	2113741F49	10nF 50V
C3152	2113741F49	10nF 50V
C3202	2113741F49	10nF 50V
C3203	2113741F49	10nF 50V
C3205	2113741F49	10nF 50V
C3206	2311049A57	TANT CP 10uF 10% 16V
C3208	2113743E20	100nF 16V
C3209	2113743E20	100nF 16V
C3210	2311049A40	TANT CP 2.2uF 10% 10V
C3211	2113743E20	100nF 16V
C3213	2311049A40	TANT CP 2.2uF 10% 10V
C3214	2311049A09	TANT CP 2.2uF 10% 20V
C3215	2311049A09	TANT CP 2.2uF 10% 20V
C3221	2113743E20	100nF 16V
C3222	2113743E20	100nF 16V
C3224	0882422W23	FILM SM 1.0uF 15V 5%
C3225	2113743E20	100nF 16V
C3226	2113740F25	8.2pF 5% 50V
C3227	2113740F51	100pF 5% 50V
C3228	2113743E20	100nF 16V
C3229	2113743E12	47nF 10%
C3231	2113741F49	10nF 50V
C3232	2113741F49	10nF 50V
C3233	2311049A40	TANT CP 2.2uF 10%
C3234	2113741F49	10nF 50V
C3235	2113741F49	10nF 50V
C3242	2113740F59	220pF 5% 50V
C3243	2113740F59	220pF 5% 50V
C3244	2113740F59	220pF 5% 50V
C3245	2113740F59	220pF 5% 50V
C3246	2113740F59	220pF 5% 50V
C3247	2113740F27	10pF 5% 50V
C3251	2113743E20	100nF 16V
C3252	2113741F25	1nF 50V
C3253	2311049A56	TANT CP 4.7uF 20% 10V
C3254	2113743E20	100nF 16V
C3255	2311049A40	TANT CP 2.2uF 10% 10V
C3263	2113743E20	100nF 16V
C3302	2113740F23	6.8pF 5% 50V
C3303	2113741F49	10nF 50V
C3306	2113740F20	5.1pF 5% 50V
C3311	2113743E07	22nF 16V
C3314	2113740F23	6.8pF 5% 50V
C3315	2113740F31	15pF 5% 50V
C3316	2113740F15	3.3pF 5% 50V
C3317	2113740F39	33pF 5% 50V
C3318	2113740F21	5.6pF 5% 50V
C3319	2113741F25	1nF 50V
C3324	2113741F49	10nF 50V
C3332	2113743E20	100nF 16V
C3333	2113743E20	100nF 16V
C3334	2113743E07	22nF 16V
C3335	2113741F49	10nF 50V

Circuit Ref	Motorola Part No	Description
C3336	2113741F49	10nF 50V
C3337	2113743E20	100nF 16V
C3341	2113741F25	1nF 50V
C3342	2113740L05	3.0pF +/-0.1pF
C3344	2113740F09	1.8pF 5% 50V
C3345	2113740L25	20pF +/-0.25pF
C3346	2113741F49	10nF 50V
C3347	2113741F49	10nF 50V
C3348	2113741F49	10nF 50V
C3351	2113741F49	10nF 50V
C3352	2113743E07	22nF 16V
C3355	2113741F49	10nF 50V
C3356	2113743E07	22nF 16V
C3357	2113740F24	7.5pF 5% 50V
C3361	2113741F25	1nF 50V
C3362	2113740F21	5.6pF 5% 50V
C3363	2113740F47	68pF 5% 50V
C3364	2113740F31	15pF 5% 50V
C3365	2113741F25	1nF 50V
C3400	2113741F33	2.2nF 50V
C3401	2113741F33	2.2nF 50V
C3402	2113743E07	22nF 16V
C3404	2113741F33	2.2nF 50V
C3405	2113740A79	1nF 5% 50V
C3406	2113740A79	1nF 5% 50V
C3407	2113741F33	2.2nF 50V
C3408	2113740F33	18pF 5% 50V
C3409	2113741F33	2.2nF 50V
C3410	2113743E07	22nF 16V
C3411	2113743E07	22nF 16V
C3412	2113741F33	2.2nF 50V
C3413	2113743E07	22nF 16V
C3414	2113741F33	2.2nF 50V
C3415	2113743E07	22nF 16V
C3416	2113741F33	2.2nF 50V
C3417	2113741F33	2.2nF 50V
C3418	2113740F36	24pF 5% 50V
C3420	2113740F49	82pF 5% 50V
C3421	2113741A45	10nF 50V
C3422	2113740A79	1nF 5% 50V
C3424	2113741A45	10nF 50V
C3425	2113928E01	1uF 10% 10V
C3426	2113741F33	2.2nF 50V
C3428	2113741F33	2.2nF 50V
C3430	2113740A41	33pF 5% 50V
C3431	2113740A61	180pF 5% 50V
C3432	2113740A53	82pF 5% 50V
C3433	2113740A29	10pF 5% 50V
C3434	2113928E01	1uF 10% 10V
C3435	2113741F33	2.2nF 50V
C3436	2311049A45	TANT CP 10uF 10% 35V
C3437	2113741M69	0.1uF 50V
C3439	2113741W01	1uF 10% 25V
C3440	2113741M69	0.1uF 50V
C3441	2113740A79	1nF 5% 50V
C3442	2111078B57	HQ 390pF 5%

Circuit Ref	Motorola Part No	Description
C3443	2111078B51	RF 220 5 NPO 100V
C3444	2111078B51	RF 220 5 NPO 100V
C3445	2113740A79	1nF 5% 50V
C3446	2180464E50	56pF 5% 250V
C3447	2180464E50	56pF 5% 250V
C3448	2111078B31	HQ 36pF 5%
C3449	2111078B31	HQ 36pF 5%
C3450	2111078B38	HQ 68pF 5%
C3451	2111078B20	HQ 18pF 5%
C3452	2111078B38	HQ 68pF 5%
C3455	2111078B36	HQ 56pF 5%
C3456	2113740A79	1nF 5% 50V
C3457	2113740A79	1nF 5% 50V
C3458	2113741A45	10nF 50V
C3459	2180464E16	100pF 5% 250V
C3460	2113743E20	100nF 16V
C3461	2113741F33	2.2nF 50V
C3464	2113740F28	11pF 5% 50V
C3465	2113740A79	1nF 5% 50V
C3466	2113740A79	1nF 5% 50V
C3467	2111078B40	HQ 82pF 5%
C3468	2111078B20	HQ 18pF 5%
C3471	2113743E07	22nF 16V
C3472	2111078B47	HQ 150pF 5%
C3473	2111078B47	HQ 150pF 5%
C3474	2113740A79	1nF 5% 50V
C3475	2113740F33	18pF 5% 50V
C3478	2113741F33	2.2nF 50V
C3489	2111078B45	HQ 130pF 5%
C3490	2111078B31	HQ 36pF 5%
C3492	2111078B59	HQ 470pF 5%
C3494	2111078B34	HQ 47pF 5%
C3496	2111078B33	HQ 43pF 5%
C3497	2111078B21	HQ 20pF 5%
C3498	2111078B34	HQ 47pF 5%
C3501	2113741F33	2.2nF 50V
C3502	2113741F33	2.2nF 50V
C3503	2113741F33	2.2nF 50V
C3504	2113741F33	2.2nF 50V
C3505	2311049A07	TANT CP 1uF 10% 16V
C3506	2113741F33	2.2nF 50V
C3507	2113740F51	100pF 5% 50V
C3508	2113741F33	2.2nF 50V
C3509	2113741F33	2.2nF 50V
C3510	2113743E20	100nF 16V
D3000	4813833C02	DUAL SOT MMBD6100
D3001	4805649Q13	VCTR 1SV228 SOT23
D3003	4880154K03	DUAL SCHOTTKY SOT23
D3004	4805649Q13	VCTR 1SV228 SOT23
D3011	4880142L01	PIN
D3031	4886143B01	MIXER DIODE CROSSOVER
D3101	4880154K03	DIODE DUAL SCHOTTKY
D3201	4802233J09	TRIPLE SOT143-RH
D3221	4880236E05	CHIP SCHOTTKY
D3341	4805649Q13	VCTR 1SV228 SOT23
D3361	4805649Q13	VCTR 1SV228 SOT23

Circuit Ref	Motorola Part No	Description
D3362	4862824C01	VARACTOR CHIP
D3451	4882290T02	HOT CARRIER HSMS2802
D3452	4882290T02	HOT CARRIER HSMS2802
D3471	4802482J02	PIN MA/COM
D3472	4802482J02	PIN MA/COM
FL3101	9180112R16	44.85 MHZ XSTAL FLTR 80dB
FL3102	9180112R16	44.85 MHZ XSTAL FLTR 80dB
FL3111	9180469V03	CER FLTR 6EL 455 KHZ SMD
FL3112	9180469V06	CER FLTR 6EL 455 KHZ SMD
FL3113	9180468V04	CER FLTR 4EL 455 KHZ SMD
FL3114	9180468V06	CER FLTR 4EL 455 KHZ SMD
J3401	0986166B02	RF CONN MINI UHF
L3002	2462587T23	COIL CHIP 470nH
L3031	2462587T24	COIL CHIP 560nH
L3032	2462587T17	COIL CHIP 150nH
L3101	2462587T25	COIL CHIP 620nH
L3111	2462587T25	COIL CHIP 620nH
L3112	2462587T25	COIL CHIP 620nH
L3201	2462587Q42	IND CHIP 390nH 10%
L3231	2462587Q20	IND CHIP 2.2uH 20%
L3301	2462587N44	CHIP IND 18 NH 5%
L3302	2462587N53	CHIP IND 100 nH 5%
L3317	2462587V28	CHIP IND 33 NH 5%
L3318	2462587V34	IND CHIP 100nH 5%
L3331	2462587V32	CHIP IND 68NH 5%
L3332	2462587V15	IND CHIP 100nH 10%
L3333	2462587Q47	IND CHIP 1uH 10%
L3341	2484562T13	MINI-SPRING AW IND 8NH 2%
L3343	2462587N56	COIL CHIP 180nH 5%
L3344	2462587N68	CHIP IND 1 uH 5%
L3345	2462587N68	CHIP IND 1 uH 5%
L3346	2484562T18	MINI-SPRING AW IND 35.5NH 2%
L3351	2462587N68	CHIP IND 1 uH 5%
L3361	2462587N50	CHIP IND 56 nH 5%
L3362	2462587N51	CHIP IND 68 nH 5%
L3363	2462587N50	CHIP IND 56 nH 5%
L3364	2462587N68	CHIP IND 1 uH 5%
L3401	2462587X48	IND CHIP LO-PRO 39nH 5%
L3402	2484657R01	Ferrite Bead
L3403	2462587T13	COIL CHIP 68nH
L3411	2462587T13	COIL CHIP 68nH
L3412	2462587X47	IND CHIP LO-PRO 33.0 N
L3413	2462587X46	IND CHIP LO-PRO 27.0 N
L3414	2460591A01	SQUARE COIL 4.22nH 3T
L3421	2484657R01	Ferrite Bead
L3422	2460591C73	COIL AIRW 16.96nH 10% 5TNS
L3423	2460591B73	SQUARE COIL 12.77nH 10%
L3431	2484657R01	Ferrite Bead
L3432	2460591F77	SQUARE COIL 35.5nH 10% 8T AWG22 U
L3433	2460591B73	SQUARE COIL 12.77nH 10%
L3441	2460591E77	SQUARE COIL 30nH 10% 7T
L3442	2484657R01	Ferrite Bead

Circuit Ref	Motorola Part No	Description
L3443	2484657R01	Ferrite Bead
L3444	2460591X03	COIL SQUARE 5 TNS
L3445	2460591X01	COIL SQUARE
L3471	2462587X69	IND CHIP 1.2uH 5%
L3472	2460591X05	COIL SQUARE 48nH 10% 7TNS
L3473	2462587X69	IND CHIP 1.2uH 5%
L3474	2462587N42	CHIP IND 12nH 5%
L3475	2462587N55	CHIP IND 150nH 5%
L3477	2462587X69	IND CHIP 1.2uH 5%
L3491	2460592B01	COIL AW 51nH 4T
L3492	2460592B01	COIL AW 51nH 4T
L3493	2460592B01	COIL AW 51nH 4T
L3494	2460592B01	COIL AW 51nH 4T
Q3001	4813827A07	NPN SML SIG MMBR9
Q3002	4813824A17	PNP 40V .2A B=100-
Q3021	4805921T02	DUAL ROHM FMC2
Q3101	4813827A07	NPN SML SIG MMBR9
Q3102	4813827A07	NPN SML SIG MMBR9
Q3141	4813824A10	NPN 40V .2A B=50-150
Q3151	4880048M01	NPN DIG 47k/47k
Q3152	4880048M01	NPN DIG 47k/47k
Q3221	4880048M01	NPN DIG 47k/47k
Q3301	4813827A07	NPN SML SIG MMBR9
Q3303	4802245J50	DUAL NPN/PNP UMC5N
Q3304	4805218N63	RF TRANS SOT 323 Bfq67W
Q3421	5105385Y91	LD MOS PWR MODULE 16 CELL
Q3431	4805537W01	MRF5015 MOS1
Q3441	4884411L04	RF PWR TSTR MRF247 75W
Q3471	4880048M01	NPN DIG 47k/47k
Q3472	4805128M27	PNP SOT89 BSR33 LH
Q3501	4813824A17	PNP 40V .2A B=100-
Q3502	4813824A10	NPN 40V .2A B=50-150
R3000	0662057A53	1k5 1/16W 5%
R3001	0662057A97	100k 1/16W
R3002	0662057A43	560 1/16W 5%
R3003	0662057A49	1k 1/16W 5%
R3004	0662057A53	1k5 1/16W 5%
R3006	0662057A73	10k 1/16W 5%
R3009	0662057A97	100k 1/16W
R3010	0662057A45	680 OHMS 5%
R3011	0662057A65	4k7 1/16W 5%
R3012	0662057A49	1k 1/16W 5%
R3013	0662057A61	3k3 1/16W 5%
R3014	0662057A18	51 1/16W 5%
R3015	0662057A01	10 1/16W 5%
R3016	0662057A01	10 1/16W 5%
R3018	0662057A33	220 1/16W 5%
R3019	0662057A89	47k 1/16W 5%
R3021	0662057A43	560 1/16W 5%
R3024	0662057A39	390 1/16W 5%
R3025	0662057A53	1k5 1/16W 5%
R3026	0662057A73	10k 1/16W 5%
R3027	0662057A73	10k 1/16W 5%
R3028	0662057A39	390 1/16W 5%

Circuit Ref	Motorola Part No	Description
R3031	0662057A18	51 1/16W 5%
R3033	0662057B47	0 1/16W
R3101	0662057A75	12k 1/16W 5%
R3102	0662057A01	10 1/16W 5%
R3105	0662057A25	100 1/16W 5%
R3106	0662057A83	27k 1/16W 5%
R3107	0662057A69	6k8 1/16W 5%
R3108	0662057A44	620 OHMS 5%
R3111	0662057A75	12k 1/16W 5%
R3112	0662057A01	10 1/16W 5%
R3113	0662057A37	330 1/16W 5%
R3115	0662057A39	390 1/16W 5%
R3116	0662057A37	330 1/16W 5%
R3117	0662057A83	27k 1/16W 5%
R3118	0662057A69	6k8 1/16W 5%
R3130	0662057A18	51 1/16W 5%
R3132	0662057A77	15k 1/16W 5%
R3133	0662057A71	8k2 1/16W 5%
R3134	0662057A73	10k 1/16W 5%
R3135	0662057A51	1k2 1/16W 5%
R3141	0662057A39	390 1/16W 5%
R3142	0662057A55	1k8 1/16W 5%
R3144	0662057A58	2k4 1/16W 5%
R3145	0662057A61	3k3 1/16W 5%
R3146	0662057A45	680 OHMS 5%
R3147	0662057A75	12k 1/16W 5%
R3151	0662057A73	10k 1/16W 5%
R3152	0662057A73	10k 1/16W 5%
R3153	0662057A73	10k 1/16W 5%
R3154	0662057A73	10k 1/16W 5%
R3201	0662057A17	47 1/16W 5%
R3203	0662057A17	47 1/16W 5%
R3204	0662057A17	47 1/16W 5%
R3211	0662057B47	0 1/16W
R3221	0662057A39	390 1/16W 5%
R3222	0662057A45	CHIP RES 680 OHMS 5%
R3223	0662057A25	100 1/16W 5%
R3224	0662057A89	47k 1/16W 5%
R3225	0662057A89	47k 1/16W 5%
R3227	0662057A97	100k 1/16W
R3241	0662057A25	100 1/16W 5%
R3242	0662057B47	0 1/16W
R3251	0662057B04	180k 1/16W 5%
R3252	0662057B10	330k 1/16W 5%
R3261	0662057A89	47k 1/16W 5%
R3263	0662057A65	4k7 1/16W 5%
R3301	0662057A22	75 1/16W 5%
R3302	0662057A25	100 1/16W 5%
R3303	0662057A57	2k2 1/16W 5%
R3304	0662057A49	1k 1/16W 5%
R3308	0662057B47	0 1/16W
R3311	0662057A25	100 1/16W 5%
R3316	0662057B47	0 1/16W
R3318	0662057A09	22 1/16W 5%
R3321	0662057A73	10k 1/16W 5%
R3323	0662057A49	1k 1/16W 5%

Circuit Ref	Motorola Part No	Description
R3331	0662057A17	47 1/16W 5%
R3335	0662057A13	33 1/16W 5%
R3336	0662057A77	15k 1/16W 5%
R3341	0662057A33	220 1/16W 5%
R3342	0662057A15	39 1/16W 5%
R3343	0662057A25	100 1/16W 5%
R3351	0662057A80	20k 1/16W 5%
R3352	0662057A75	12k 1/16W 5%
R3353	0662057A97	100k 1/16W
R3354	0662057B02	150k 1/16W
R3355	0662057A80	20k 1/16W 5%
R3356	0662057A75	12k 1/16W 5%
R3361	0662057A33	220 1/16W 5%
R3362	0662057A17	47 1/16W 5%
R3364	0662057A89	47k 1/16W 5%
R3400	0662057A41	470 1/16W 5%
R3401	0662057A28	130 1/16W 5%
R3402	0662057A16	43 1/16W
R3403	0662057A28	130 1/16W
R3404	0662057A73	10k 1/16W
R3405	0662057A25	100 1/16W
R3406	0662057B02	150k 1/16W
R3408	0662057B02	150k 1/16W
R3410	0662057A95	82k 1/16W 5%
R3412	0662057A67	5k6 1/16W 5%
R3413	0662057A61	3k3 1/16W 5%
R3414	0683962T71	820 1W 5%
R3415	0662057A25	100 1/16W 5%
R3416	0662057A25	100 1/16W 5%
R3419	0662057C34	20 1/10W 5%
R3424	0662057K21	68 5% 1210
R3425	0662057K21	68 5% 1210
R3431	0680194M18	51 1W 5%
R3432	0680194M18	51 1W 5%
R3433	0662057C45	56 1/10W 5%
R3434	0662057C45	56 1/10W 5%
R3435	0662057C45	56 1/10W 5%
R3436	0683962T51	120 1W 5%
R3437	0683962T51	120 1W 5%
R3441	0680194M18	51 1W 5%
R3442	0662057C27	10R 1/10W 5%
R3443	0662057D48	1M 1/10W 5%
R3444	0662057D48	1M 1/10W 5%
R3453	0662057B20	820K 1/16W 5%
R3455	0662057A97	100k 1/16W
R3457	0680194M16	xx 1W 5%
R3460	0662057C01	0 1/10W 5%
R3461	0680194M20	62 1W 5%
R3462	0662057A87	39k 1/16W 5%
R3463	0662057D04	15kK 1/10W 5%
R3464	0662057C01	0 1/10W 5%
R3465	0662057B06	220k 1/16W
R3471	0662057A41	470 1/16W 5%
R3473	0680194M18	51 1W 5%
R3474	0680194M18	51 1W 5%
R3475	0662057A73	10k 1/16W 5%

Circuit Ref	Motorola Part No	Description
R3490	0662057A89	47k 1/16W 5%
R3501	0662057A69	6k8 1/16W 5%
R3502	0662057A87	39k 1/16W 5%
R3503	0662057A49	1k 1/16W 5%
R3504	0662057A49	1k 1/16W 5%
R3505	0662057C71	680 1/10W 5%
R3506	0662057C71	680 1/10W 5%
R3507	0662057C71	680 1/10W 5%
R3508	0662057C71	680 1/10W 5%
R3509	0662057A73	10k 1/16W 5%
R3510	0662057A80	20k 1/16W 5%
R3511	0662057A97	100k 1/16W
R3512	0662057A97	100k 1/16W
R3513	0611079A69	6k8 1/16W 5%
R3514	0611079A69	6k8 1/16W 5%
R3515	0611079A69	6k8 1/16W 5%
R3516	0611079A69	6k8 1/16W 5%
R3517	0662057A97	100k 1/16W
RT3460	0605621T02	THERMISTOR CHIP
T3001	2508396X02	TRANSFORMER
T3002	2508397X02	TRANSFORMER
U3101	5186144B01	FM IF IC SA616
U3111	5113805A86	IC QUAD ANALOG MUX/ DEMUX
U3115	5113805A86	IC QUAD ANALOG MUX/ DEMUX
U3201	5185963A27	IC TESTED AT25016 48 PIN GFP
U3211	5105739X05	IC SOT 5V HI-PRECISION REGULAT
U3301	5105750U54	VCO BUFFER PKG DIE
U3401	5185130C65	IC VHF/UHF/800MHz LDMOS DRIVER
U3501	5185765B01	IC POWER CONTROL
U3502	5185963A15	TEMP SENSOR 1M5
VR3471	4813830A15	5.6V 5% 225mW
Y3101	4880606B09	CRYSTAL 44.395 MHZ
Y3102	9186145B02	CERAMIC DISCRIMINATOR 455kHz
Y3263	4886182B01	VCTCXO 16.8MHz 2ppm TTSO5V
* Y3261	Not Used	16.8MHz 75Z04

* Motorola Depot Servicing only

Reference designators with an asterisk indicate components which are not fieldreplaceable because they need to be calibrated with specialized factory equipment after installation. Radios in which these parts have been replaced in the field will be off frequency at temperature extremes.



Professional Radio

GM Series

Controller
Service Information

Computer Software Copyrights

The Motorola products described in this manual may include copyrighted Motorola computer programs stored in semiconductor memories or other media. Laws in the United States and other countries preserve for Motorola certain exclusive rights for copyrighted computer programs, including the exclusive right to copy or reproduce in any form, the copyrighted computer program. Accordingly, any copyrighted Motorola computer programs contained in the Motorola products described in this manual may not be copied or reproduced in any manner without the express written permission of Motorola. Furthermore, the purchase of Motorola products shall not be deemed to grant, either directly or by implication, estoppel or otherwise, any license under the copyrights, patents or patent applications of Motorola, except for the normal non-exclusive royalty-free license to use that arises by operation of law in the sale of a product.

Table of Contents

Chapter 1 THEORY OF OPERATION

1.0	Controller Circuits	1-1
1.1	Overview.....	1-1
1.2	General.....	1-1
1.3	Radio Power Distribution	1-2
1.4	Electronic ON/OFF	1-3
1.5	Emergency	1-4
1.6	Mechanical ON/OFF.....	1-4
1.7	Ignition	1-5
1.8	Microprocessor Clock Synthesizer	1-5
1.9	Serial Peripheral Interface (SPI).....	1-5
1.10	SBEP Serial Interface.....	1-6
1.11	General Purpose Input/Output	1-6
1.12	Normal Microprocessor Operation.....	1-7
1.13	FLASH Electronically Erasable Programmable Memory	1-8
1.14	Electrically Erasable Programmable Memory (EEPROM).....	1-9
1.15	Static Random Access Memory (SRAM)	1-9
1.16	Universal Asynchronous Receiver Transmitter (UART)	1-9
2.0	Controller Board Audio and Signalling Circuits.....	1-9
2.1	General - Audio Signalling Filter IC with Compander	1-9
2.2	Transmit Audio Circuits	1-10
2.3	Transmit Signalling Circuits	1-12
2.4	Receive Audio Circuits	1-14
2.5	Receive Signalling Circuits.....	1-17
2.6	Voice Storage	1-18

Chapter 2 TROUBLESHOOTING CHARTS

1.0 Controller	2-1
----------------------	-----

Chapter 3 CONTROLLER SCHEMATICS

1.0 Allocation of Schematics and Circuit Boards	3-1
2.0 T2 Controller	3-3
3.0 T5 Controller	3-10
4.0 T6/7 Controller	3-19
5.0 T9 Controller	3-29

Chapter 1

THEORY OF OPERATION

1.0 Controller Circuits

1.1 Overview

This section provides a detailed theory of operation for the radio and its components. The main radio is a single board design, consisting of the transmitter, receiver, and controller circuits. The main board is designed to accept one additional option board. This may provide functions such as secure voice/data, voice storage or signalling decoder.

A controlhead is either mounted directly or connected by an extension cable. The controlhead contains, LED indicators, a microphone connector, buttons and dependant of the radio type, a display and a speaker. These provide the user with interface control over the various features of the radio.

If no controlhead is mounted directly on the front of the radio, an expansion board containing circuitry for special applications can be mounted on the front of the radio. An additional controlhead can be connected by an extension cable.

In addition to the power cable and antenna cable, an accessory cable can be attached to a connector on the rear of the radio. The accessory cable provides the necessary connections for items such as external speaker, emergency switch, foot operated PTT, and ignition sensing, etc

1.2 General

The radio controller consists of 3 main subsections:

- Digital Control
- Audio Processing
- Voltage Regulation.

The digital control section of the radio is based upon an open architecture controller configuration. It consists of a microprocessor, support memory, support logic, signal MUX ICs, the On/Off circuit, and general purpose Input/Output circuitry.

The controller uses the Motorola 68HC11FL0 microprocessor (U0101). In addition to the microprocessor, the controller has 3 external memory devices. The 3 memory devices consist of a 32Kbyte SRAM (U0122), a 512Kbyte FLASH EEPROM (U0121), and a 16Kbyte EEPROM (U0111).

Note: From this point on the 68HC11FL0 microprocessor will be referred to as μ P. References to a controlhead will be to the controlheads with display.

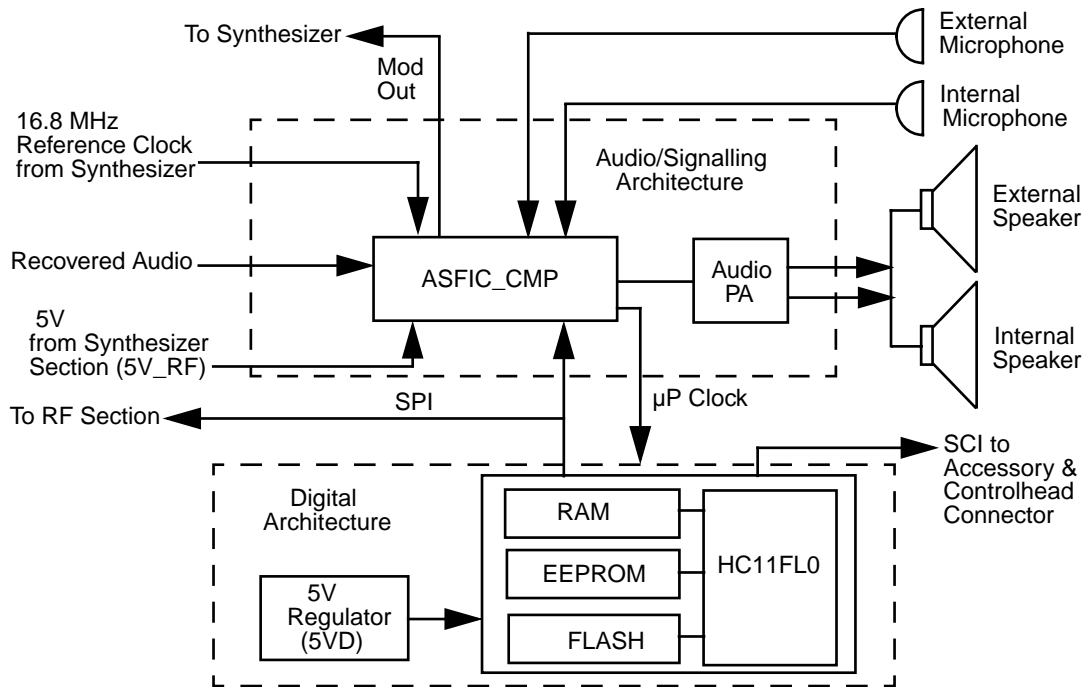

Figure 1-1 Controller Block Diagram

1.3 Radio Power Distribution

The DC power distribution throughout the radio board is shown in Figure 2-1. Voltage regulation for the controller is provided by 4 separate devices; U0651 (MC78M05) +5V, U0641 (LM2941) +9.3V, U0611 (LM2941) SWB+ limited to 16.5V and VSTBY 5V (a combination of R0621 and VR0621). An additional 5V regulator is located on the RF section.

The DC voltage applied to connector J0601 supplies power directly to the electronic on/off control, RF power amplifier, 16.5V limiter, 9.3V regulator, Audio PA and 5.6V stabilization circuit. The 9.3V regulator (U0641) supplies power to the 5V regulator (U0651) and the 6V voltage divider Q0681.

Regulator U0641 is used to generate the 9.3 volts required by some audio circuits, the RF circuitry and power control circuitry. Input and output capacitors (C0641 and C0644 / C0645) are used to reduce high frequency noise. R0642 / R0643 set the output voltage of the regulator. If the voltage at pin 1 is greater than 1.3 volts the regulator output decreases and if the voltage is less than 1.3 volts the regulator output increases. This regulator output is electronically enabled by a 0 volt signal on pin 2. Q0661, Q0641 and R0641 are used to disable the regulator when the radio is turned off.

Voltage regulation providing 5V for the digital circuitry is done by U0651. Operating voltage is from the regulated 9.3V supply. Input and output capacitors (C0651 / C0652 and C0654 / C0655) are used to reduce high frequency noise and provide proper operation during battery transients. Voltage sense device U0652 or alternatively U0653 provides a reset output that goes to 0 volts if the regulator output goes below 4.5 volts. This is used to reset the controller to prevent improper operation. Diode D0651 prevents discharge of C0652 by negative spikes on the 9V3 voltage.

Transistor Q0681 and resistors R0681 / R0682 divide the regulated 9.3V down to about 6 volts. This voltage supplies the 5V regulator, located on the RF section. By reducing the supply voltage of the regulator, the power dissipation is divided between the RF section and the controller section.

The voltage VSTBY, which is derived directly from the supply voltage by components R0621 and VR0621, is used to buffer the internal RAM. C0622 allows the battery voltage to be disconnected for a couple of seconds without losing RAM parameters. Dual diode D0621 prevents radio circuitry from discharging this capacitor. When the supply voltage is applied to the radio, C0622 is charged via R0621 and D0621. To avoid that the μ P enters the wrong mode when the radio is switched on while the voltage across C0622 is still too low, the regulated 5V charges C0622 via diode D0621.

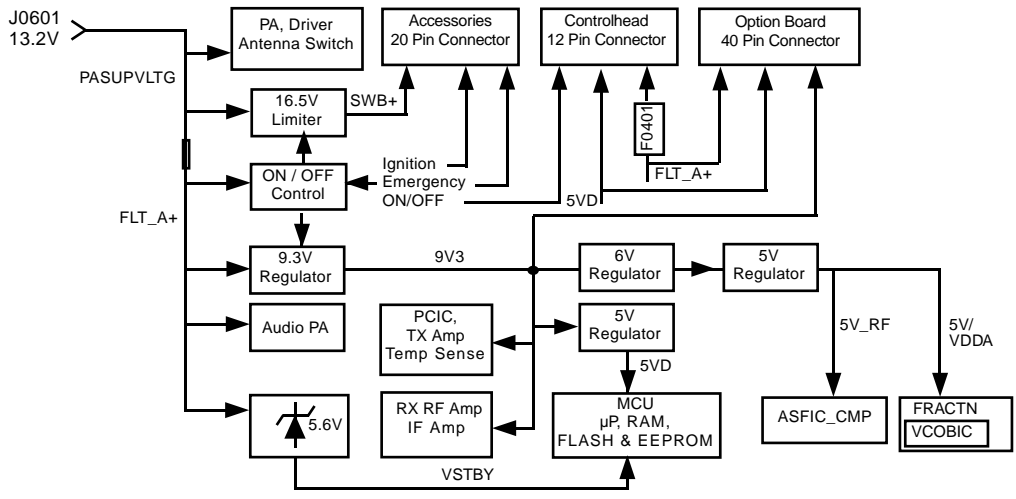

Figure 2-1 DC Power Distribution Block Diagram

The voltage INT SW B+ from switching transistor Q0661 provides power to the circuit controlling the audio PA output. The voltage INT SW B+ voltage is monitored by the μ P through voltage divider R0671 / R0672 and line BATTERY VOLTAGE. Diode VR0671 limits the divided voltage to 5.6V to protect the μ P.

Regulator U0611 is used to generate the voltage for the switched supply voltage output (SWB+) at the accessory connector J0501 pin 13. U0611 is configured to operate as a switch with voltage and current limit. R0611 / R0612 set the maximum output voltage to 16.5 volts. This limitation is only active at high supply voltage levels. The regulator output is electronically enabled by a 0 volt signal on pin 2. Q0661, Q0641 and R0641 are used to disable the regulator when the radio is turned off. Input and output capacitors (C0603 and C0611 / C0612) are used to reduce high frequency noise.

Diode VR0601 acts as protection against transients and wrong polarity of the supply voltage.

Fuse F0401 prevents damage of the board in case the FLT A+ line is shorted at the controlhead connector.

1.4 Electronic ON/OFF

The radio has circuitry which allows radio software and/or external triggers to turn the radio on or off without direct user action. For example, automatic turn on when ignition is sensed and off when ignition is off.

Q0661 is used to provide INT SW B+ to the various radio circuits and to enable the voltage regulators via transistor Q0641. Q0661 contains an pnp and an npn transistor and acts as an electronic on/off switch. The switch is on when the collector of the npn transistor within Q0661 is low. When the radio is off the collector is at supply voltage level. This effectively prevents current flow

from emitter to collector of the pnp transistor. When the radio is turned on the voltage at the base of the npn transistor is pulled high and the pnp transistor switches on (saturation). With voltage INT SWB+ now at supply voltage level, transistor Q0641 pulls pin 2 of the voltage regulators U0611 and U 0641 to ground level and thereby enables their outputs.

The electronic on/off circuitry can be enabled by the microprocessor (through ASFIC CMP port GCB2, line DC POWER ON), the emergency switch (line EMERGENCY CONTROL), the mechanical On/Off/Volume knob on the controlhead (line ON OFF CONTROL), or the ignition sense circuitry (line IGNITION CONTROL). If any of the 4 paths cause a low at the collector of the npn transistor within Q0661, the electronic "ON" is engaged.

1.5 Emergency

The emergency switch (J0501 pin 9), when engaged, grounds the base of Q0662 via line EMERGENCY CONTROL. This switches Q0662 off and resistor R0662 pulls the collector of Q0662 and the base of Q0663 to levels above 2 volts. Transistor Q0663 switches on and pulls the collector of the npn transistor within Q0661 to ground level and thereby enables the voltage regulators via Q0641. When the emergency switch is released R0541 pulls the base of Q0662 up to 0.6 volts. This causes the collector of transistor Q0662 to go low (0.2V), thereby switching Q0663 off.

While the radio is switched on, the microprocessor monitors the voltage at the emergency input on the accessory connector via pin 60 and line GP5 IN ACC9. Three different conditions are distinguished, no emergency, emergency, and open connection to the emergency switch. If no emergency switch is connected or the connection to the emergency switch is broken, the resistive divider R0541 / R0512 will set the voltage to about 4.7 volts. If an emergency switch is connected, a resistor to ground within the emergency switch will reduce the voltage on line GP5 IN ACC9 to inform the microprocessor that the emergency switch is operational. An engaged emergency switch pulls line GP5 IN ACC9 to ground level. Diode D0179 limits the voltage to protect the microprocessor input.

While EMERGENCY CONTROL is low, INT SW B+ is on, the microprocessor starts execution, reads that the emergency input is active through the voltage level of line GP5 IN ACC9, and sets the DC POWER ON output of the ASFIC CMP pin 13 to a logic high. This high will keep Q0661 and Q0641 switched on. This operation allows a momentary press of the emergency switch to power up the radio. When the microprocessor has finished processing the emergency press, it sets the DC POWER ON line to a logic 0. This turns off Q0661 and the radio turns off. Notice that the microprocessor is alerted to the emergency condition via line GP5 IN ACC9. If the radio was already on when emergency was triggered then DC POWER ON would already be high.

1.6 Mechanical ON/OFF

This refers to the typical on/off/volume knob, located on the controlhead, and which turns the radio on and off.

If the radio is turned off and the on/off/volume knob is pressed, line ON OFF CONTROL (J0401 pin 11) goes high and switches the radio's voltage regulators on as long as the button is pressed. The microprocessor is alerted through line ON OFF SENSE (U0101 pin 6) which is pulled to low by Q0110 while the on / off / volume knob is pressed. In addition, an interrupt is generated at μ P pin 96. The μ P asserts line DC POWER ON via ASFIC CMP, pin 13 high which keeps Q0661 and Q0641, and in turn the radio, switched on. When the on/off/volume knob is released again the controlhead informs the μ P via SBEP bus about the knob release. (See SBEP Serial Interface subsection for more details). This informs the μ P to keep the radio switched on and continue with normal operation. If the on/off/volume knob is pressed while the radio is on, the controlhead informs the μ P via SBEP bus about the knob status. (See SBEP Serial Interface subsection for more details). After a short delay time the microprocessor switches the radio off by setting DC POWER ON to low via ASFIC CMP pin 13.

1.7 Ignition

Ignition sense is used to prevent the radio from draining the vehicle's battery because the engine is not running.

When the IGNITION input (J0501 pin 10) goes above 5 volts Q0661 is turned on via line IGNITION CONTROL. Q0661 turns on INT SW B+ and the voltage regulators by turning on Q0641 and the microprocessor starts execution. The microprocessor is alerted through line GP6 IN ACC10. The voltage at the IGNITION input turns Q0181 on, which pulls microprocessor pin 74 to low. If the software detects a low state it asserts DC POWER ON via ASFIC pin 13 high which keeps Q0661 and Q0641, and in turn the radio switched on.

When the IGNITION input goes below 3 volts, Q0181 switches off and R0181 pulls microprocessor pin 74 to high. This alerts the software to switch off the radio by setting DC POWER ON to low. The next time the IGNITION input goes above 5 volts the above process will be repeated.

1.8 Microprocessor Clock Synthesizer

The clock source for the microprocessor system is generated by the ASFIC CMP (U0221). Upon power-up the synthesizer IC (FRAC-N) generates a 16.8 MHz waveform that is routed from the RF section to the ASFIC CMP pin 34. For the main board controller the ASFIC CMP uses 16.8 MHz as a reference input clock signal for its internal synthesizer. The ASFIC CMP, in addition to audio circuitry, has a programmable synthesizer which can generate a synthesized signal ranging from 1200Hz to 32.769MHz in 1200Hz steps.

When power is first applied, the ASFIC CMP will generate its default 3.6864MHz CMOS square wave UP CLK (on U0221 pin 28) and this is routed to the microprocessor (U0101 pin 90). After the microprocessor starts operation, it reprograms the ASFIC CMP clock synthesizer to a higher UP CLK frequency (usually 7.3728 or 14.7456 MHz) and continues operation.

The ASFIC CMP may be reprogrammed to change the clock synthesizer frequencies at various times depending on the software features that are executing. In addition, the clock frequency of the synthesizer is changed in small amounts if there is a possibility of harmonics of this clock source interfering with the desired radio receive frequency.

The ASFIC CMP synthesizer loop uses C0245, C0246 and R0241 to set the switching time and jitter of the clock output. If the synthesizer cannot generate the required clock frequency it will switch back to its default 3.6864MHz output.

Because the ASFIC CMP synthesizer and the μ P system will not operate without the 16.8 MHz reference clock it (and the voltage regulators) should be checked first in debugging the system.

The microprocessor uses XTAL Y0131 and associated components to form a Real Time Clock (RTC). It may be used to display the time on controlheads with display or as time stamp for incoming calls or messages. The real time clock is powered from the voltage VSTBY to keep it running while the radio is switched off. When the radio was disconnected from its supply voltage, the time must be set again.

1.9 Serial Peripheral Interface (SPI)

The μ P communicates to many of the IC's through its SPI port. This port consists of SPI TRANSMIT DATA (MOSI) (U0101-100), SPI RECEIVE DATA (MISO) (U0101-99), SPI CLK (U0101-1) and chip select lines going to the various ICs, connected on the SPI PORT (BUS). This BUS is a synchronous bus, in that the timing clock signal CLK is sent while SPI data (SPI TRANSMIT DATA or SPI RECEIVE DATA) is sent. Therefore, whenever there is activity on either SPI TRANSMIT DATA or SPI RECEIVE DATA there should be a uniform signal on CLK. The SPI TRANSMIT DATA is used to send serial from a μ P to a device, and SPI RECEIVE DATA is used to send data from a device to a μ P.

On the controller there are two ICs on the SPI BUS, ASFIC CMP (U0221-22), and EEPROM (U0111-5). In the RF sections there are 2 ICs on the SPI BUS, the FRAC-N Synthesizer, and the Power Control IC (PCIC). The SPI TRANSMIT DATA and CLK lines going to the RF section are filtered by L0481 / R0481 and L0482 / R0482 to minimize noise. The chip select line CSX from U0101 pin 2 is shared by the ASFIC CMP, FRAC-N Synthesizer and PCIC. Each of these IC's check the SPI data and when the sent address information matches the IC's address, the following data is processed. The chip select lines for the EEPROM (EE CS), Voice Storage (VS CS), expansion board (EXP1 CS, EXP2 CS) and option board (OPT CS) are decoded by the address decoder U0141.

When the μ P needs to program any of these IC's it brings the chip select line CSX to a logic 0 and then sends the proper data and clock signals. The amount of data sent to the various IC's are different, for example the ASFIC CMP can receive up to 19 bytes (152 bits) while the PCIC can receive up to 6 bytes (48 bits). After the data has been sent the chip select line is returned to logic 1.

The Option board interfaces are different in that the μ P can also read data back from devices connected. The timing and operation of this interface is specific to the option connected, but generally follows the pattern:

1. an option board device generates a service request via J0551-29, line RDY and μ P pin 79,
2. the main board asserts a chip select for that option board device via U0141-14, line OPT CS, J0551-30,
3. the main board μ P generates the CLK (J0551-3),
4. the main board μ P writes serial data via J0551-15 and reads serial data via J0551-16 and,
5. when data transfer is complete the main board terminates the chip select and CLK activity.

1.10 SBEP Serial Interface

The SBEP serial interface allows the radio to communicate with the Customer Programming Software (CPS), or the Universal Tuner via the Radio Interface Box (RIB). This interface connects to the microphone connector via controlheadcontrolhead connector (J0401-8) and to the accessory connector J0501-17 and comprises BUS+. The line is bi-directional, meaning that either the radio or the RIB can drive the line. The microprocessor sends serial data via pin 98 and D0101 and it reads serial data via pin 97. Whenever the microprocessor detects activity on the BUS+ line, it starts communication.

In addition, the SBEP serial interface is used to communicate with a connected controlhead. When a controlhead key is pressed or the volume knob is rotated, the line ON OFF CONTROL goes high. This turns on transistor Q0110 which pulls line ON OFF SENSE and μ P pin 6 to ground level. In addition, an interrupt is generated at μ P pin 96. This indicates that the controlhead wants to start SBEP communication. The microprocessor then requests the data from the controlhead. The controlhead starts sending and after all data has been send, the ON OFF CONTROL line goes low. The controlheadcontrolhead ignores any data on BUS+ during SBEP communication with the CPS or Universal Tuner.

1.11 General Purpose Input/Output

The controller provides eight general purpose lines (DIG1 through DIG8) available on the accessory connector J0501 to interface to external options. Lines DIG IN 1,3,5,6, are inputs, DIG OUT 2 is an output and DIG IN OUT 4,7,8 are bidirectional. The software and the hardware configuration of the radio model define the function of each port.

DIG IN 1 can be used as external PTT input, DATA PTT input or others, set by the CPS. The μ P reads this port via pin 77 and Q0171.

DIG OUT 2 can be used as normal output or external alarm output, set by the CPS. Transistor Q0173 is controlled by the μ P via ASFIC CMP pin 14.

DIG IN 3 is read by μ P pin 61 via resistor R0176

DIG IN 5 can be used as normal input or emergency input, set by the CPS. The μ P reads this port via R0179 and μ P pin 60. Diode D0179 limits the voltage to protect the μ P input.

DIG IN 6 can be used as normal input, set by the CPS. The μ P reads this port via pin 74 and Q0181.

DIG IN OUT 4,7,8 are bi-directional and use the same circuit configuration. Each port uses an output transistor Q0177, Q0183, Q0185 controlled by μ P pins 46, 47, 53. The ports are read by μ P pins 75, 54, 76. To use one of the ports as input the μ P must turn off the corresponding output transistor.

In addition the signals from DIG IN 1, DIG IN OUT 4 are fed to the option board connector J0551 and the expansion board connector J0451.

1.12 Normal Microprocessor Operation

For this radio, the μ P is configured to operate in one of two modes, expanded and bootstrap. In expanded mode the μ P uses external memory devices to operate, whereas in bootstrap operation the μ P uses only its internal memory. In normal operation of the radio the μ P is operating in expanded mode as described below.

In expanded mode on this radio, the μ P (U0101) has access to 3 external memory devices; U0121 (FLASH EEPROM), U0122 (SRAM), U0111 (EEPROM). Also, within the μ P there are 3Kbytes of internal RAM, as well as logic to select external memory devices.

The external EEPROM (U0111) space contains the information in the radio which is customer specific, referred to as the codeplug. This information consists of items such as: 1) what band the radio operates in, 2) what frequencies are assigned to what channel, and 3) tuning information. (See the particular device subsection for more details.)

The external SRAM (U0122) as well as the μ P's own internal RAM space are used for temporary calculations required by the software during execution. All of the data stored in both of these locations is lost when the radio powers off (See the particular device subsection for more details).

The FLASH EEPROM contains the actual Radio Operating Software. This software is common to all open architecture radios within a given model type. For example Trunking radios may have a different version of software in the FLASH EEPROM than a non Trunking radio (See the particular device subsection for more details).

The μ P provides an address bus of 16 address lines (ADDR 0 - ADDR 15), and a data bus of 8 data lines (DATA 0 - DATA 7). There are also 3 control lines; CSPROG (U0101-38) to chip select U0121-30 (FLASH EEPROM), CSGP2 (U0101-41) to chip select U0122-20 (SRAM) and PG7 R W (U0101-4) to select whether to read or to write. The external EEPROM (U0111-1), the OPTION BOARD and EXPANSION BOARD are selected by 3 lines of the μ P using address decoder U0141. The chips ASFIC CMP / FRAC-N / PCIC are selected by line CSX (U0101-2).

When the μ P is functioning normally, the address and data lines should be toggling at CMOS logic levels. Specifically, the logic high levels should be between 4.8 and 5.0V, and the logic low levels should be between 0 and 0.2V. No other intermediate levels should be observed, and the rise and fall times should be <30ns.

The low-order address lines (ADDR 0 - ADDR 7) and the data lines (DATA 0-DATA 7) should be toggling at a high rate, e. g. , you should set your oscilloscope sweep to 1us/div. or faster to observe individual pulses. High speed CMOS transitions should also be observed on the μ P control lines.

On the μP the lines XIRQ (U0101-48), MODA LIR (U0101-58), MODB VSTPY (U0101-57) and RESET (U0101-94) should be high at all times during normal operation. Whenever a data or address line becomes open or shorted to an adjacent line, a common symptom is that the RESET line goes low periodically, with the period being in the order of 20msecs. In the case of shorted lines you may also detect the line periodically at an intermediate level, i.e. around 2.5V when 2 shorted lines attempt to drive to opposite rails.

The MODA LIR (U0101-58) and MODB VSTPY (U0101-57) inputs to the μP must be at a logic 1 for it to start executing correctly. After the μP starts execution it will periodically pulse these lines to determine the desired operating mode. While the Central Processing Unit (CPU) is running, MODA LIR is an open-drain CMOS output which goes low whenever the μP begins a new instruction (an instruction typically requires 2-4 external bus cycles, or memory fetches). However, since it is an open-drain output, the waveform rise assumes an exponential shape similar to an RC circuit.

There are 8 analogue to digital converter ports (A/D) on U0101. They are labelled within the device block as PE0-PE7. These lines sense the voltage level ranging from 0 to 5V of the input line and convert that level to a number ranging from 0 to 255 which can be read by the software to take appropriate action.

For example U0101-67 is the battery voltage detect line. R0671 and R0672 form a resistor divider on INT SWB+. With 30K and 10K and a voltage range of 11V to 17V, that A/D port would see 2.74V to 4.24V which would then be converted to ~140 to 217 respectively.

U0101-69 is the high reference voltage for the A/D ports on the μP . Capacitor C0101 filters the +5V reference. If this voltage is lower than +5V the A/D readings will be incorrect. Likewise U0101-68 is the low reference for the A/D ports. This line is normally tied to ground. If this line is not connected to ground, the A/D readings will be incorrect.

1.13 FLASH Electronically Erasable Programmable Memory (FLASH EEPROM)

The 512KByte FLASH EEPROM (U0121) contains the radio's operating software. This software is common to all open architecture radios within a given model type. For example Trunking radios may have a different version of software in the FLASH EEPROM than a non Trunking radio. This is, as opposed to the codeplug information stored in EEPROM (U0111) which could be different from one user to another in the same company.

In normal operating mode, this memory is only read, not written to. The memory access signals (CE, OE and WE) are generated by the μP .

To upgrade/reprogram the FLASH software, the μP must be set in bootstrap operating mode. This is done by pulling microprocessor pins MODA LIR (U0101-58) and MODB VSTBY (U0101-57) to low during power up. When accessory connector pin 18 is at ground level, diode D0151 will pull both microprocessor pins to low. The same can be done by a level of 12 volts on line ON OFF CONTROL from the controlhead. Q0151 pulls diode D0151 and in turn both microprocessor pins to low. Diode VR0151 prevents entering bootstrap operating mode during normal power up.

In bootstrap operating mode the μP controls the FLASH EN OE (U0121-32) input by μP pin 86. Chip select (U0121-30) and read or write operation (U0121-7) are controlled by μP pins 38 and 4.

The FLASH device may be reprogrammed 1,000 times without issue. It is not recommended to reprogram the FLASH device at a temperature below 0°C.

Capacitor C0121 serves to filter out any AC noise which may ride on +5V at U0121.

1.14 Electrically Erasable Programmable Memory (EEPROM)

The external 16 Kbyte EEPROM (U0111) contains additional radio operating parameters such as operating frequency and signalling features, commonly known as the codeplug. It is also used to store radio operating state parameters such as current mode and volume. This memory can be written to in excess of 100,000 times and will retain the data when power is removed from the radio. The memory access signals (SI, SO and SCK) are generated by the μ P and chip select (CS) is generated by address decoder U0141-15.

1.15 Static Random Access Memory (SRAM)

The SRAM (U0121) contains temporary radio calculations or parameters that can change very frequently, and which are generated and stored by the software during its normal operation. The information is lost when the radio is turned off.

The device allows an unlimited number of write cycles. SRAM accesses are indicated by the CS signal U0122-20 (which comes from U0101-CSGP2) going low. U0122 is commonly referred to as the external RAM as opposed to the internal RAM which is the 3 Kbytes of RAM which is part of the 68HC11FL0. Both RAM spaces serve the purpose. However, the internal RAM is used for the calculated values which are accessed most often.

Capacitor C0122 serves to filter out any ac noise which may ride on +5V at U0122.

2.0 Controller Board Audio and Signalling Circuits

2.1 General - Audio Signalling Filter IC with Compander (ASFIC CMP)

The ASFIC CMP (U0221) used in the controller has 4 functions;

- 1) RX/TX audio shaping, i.e. filtering, amplification, attenuation
- 2) RX/TX signalling, PL/DPL/HST/MDC/MPT
- 3) Squelch detection
- 4) Microprocessor clock signal generation (see Microprocessor Clock Synthesizer Description).

The ASFIC CMP is programmable through the SPI BUS (U0221-20/21/22), normally receiving 19 bytes. This programming sets up various paths within the ASFIC CMP to route audio and/or signalling signals through the appropriate filtering, gain and attenuator blocks. The ASFIC CMP also has 6 General Control Bits GCB0-5 which are CMOS level outputs and used for NOISE BLANKER (GCB0) in Low Band radios, EXTERNAL ALARM (GCB1) and DC POWER ON (GCB2) to switch the voltage regulators (and the radio) on and off. GCB3 controls U0251 pin 11 to output either RX FLAT AUDIO or RX FILTERED AUDIO on the accessory connector pin 11. GCB4 controls U0251 pin 10 to use either the external microphone input or the voice storage playback signal. GCB5 is used to switch the audio PA on and off.

2.2 Transmit Audio Circuits

Refer to Figure 3-1 for reference for the following sections.

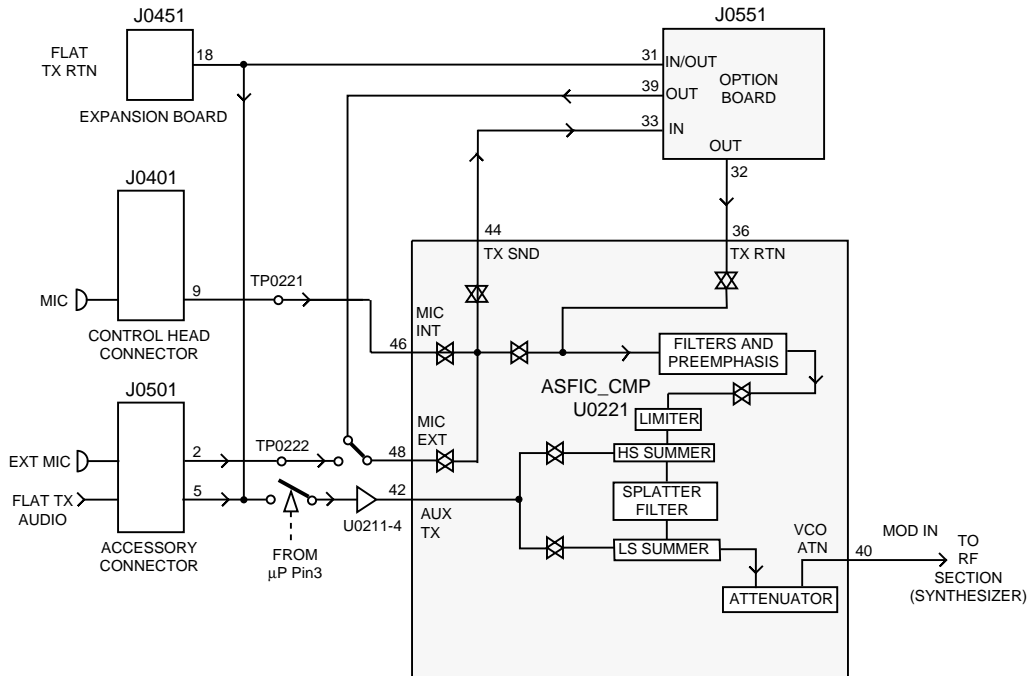

Figure 3-1 Transmit Audio Paths

2.2.1 Mic/Data Input Path

The radio supports 2 distinct microphone paths known as internal (from controlhead) and external mic (from accessory connector J0501-2) and an auxiliary path (FLAT TX AUDIO, from accessory connector J0501-5). The microphones used for the radio require a DC biasing voltage provided by a resistive network.

These two microphone audio input paths enter the ASFIC CMP at U0221-48 (external mic) and U0221-46 (internal mic). Following the internal mic path; the microphone is plugged into the radio controlhead and is connected to the controller board via J0401-9.

From here the signal is routed via R0409 and line INT MIC to R0205. R0201 and R0202 provide the 9.3VDC bias. Resistive divider R0205 / R0207 divide the input signal by 5.5 and provide input protection for the CMOS amplifier input. R0202 and C0201 provide a 560 ohm AC path to ground that sets the input impedance for the microphone and determines the gain based on the emitter resistor in the microphone's amplifier circuit.

C0204 serves as a DC blocking capacitor. The audio signal at U0221-46 (TP0221) should be approximately 14mV for 1.5kHz or 3kHz of deviation with 12.5kHz or 25kHz channel spacing.

The external microphone signal enters the radio on accessory connector J0501 pin 2 and is routed via line EXT MIC to R0206. R0203 and R0204 provide the 9.3VDC bias. Resistive divider R0206 / R0208 divide the input signal by 5.5 and provide input protection for the CMOS amplifier input. R0204 and C0202 provide a 560 ohm AC path to ground that sets the input impedance for the microphone and determines the gain based on the emitter resistor in the microphone's amplifier circuit.

C0254 serves as a DC blocking capacitor. Multi switch U0251 controlled by ASFIC CMP port GCB4 selects either the external microphone input signal or the voice storage playback signal for entering the ASFIC CMP at pin 48. The audio signal at U0221-48 (TP0222) should be approximately 14mV for 1.5kHz or 3kHz of deviation with 12.5kHz or 25kHz channel spacing.

The FLAT TX AUDIO path is used for transmitting data signals and has therefore no limiter or filters enabled inside the ASFIC CMP. When this path is enabled via CPS and DATA PTT is asserted, any signal on this path is directly fed to the modulator. Signals applied to this path either via accessory connector J0501, expansion board connector J0451 or option board connector J0551 must be filtered and set to the correct level externally or on the option board in order not to exceed the maximum specified transmit deviation and transmitted power in the adjacent channels. The attenuator inside the ASFIC CMP changes the FM deviation of the data signal according to the channel spacing of the active transmit channel.

The FLAT TX AUDIO signal from accessory connector J0501-5 is fed to the ASFIC CMP (U0221) pin42 through C0541 and line FLAT TX RTN, switch U0251 and buffer U0211-4. When the radio switches from receive to transmit mode the μ P opens switch U0251 for a short period to prevent that any applied signal can cause a transmit frequency offset. Buffer U0211-4 sets the correct DC level and ensures a short settle period when the radio is switched on. Inside the ASFIC CMP the signal is routed directly to the attenuator, which sets the FM deviation according to the channel spacing of the active transmit channel and emerges from the ASFIC CMP at U0221-40, at which point it is routed to the RF section.

The ASFIC has an internal AGC that can control the gain in the mic audio path. The AGC can be disabled / enabled by the μ P. Another feature that can be enabled or disabled in the ASFIC is the VOX. This circuit, along with the capacitor at U0221-7, provides a DC voltage that can allow the μ P to detect microphone audio. The ASFIC can also be programmed to route the microphone audio to the speaker for public address operation.

2.2.2 PTT Sensing and TX Audio Processing

Microphone PTT coming from the controlhead is sent via SBEP bus to the microprocessor. An external PTT can be generated by grounding pin 3 on the accessory connector if this input is programmed for PTT by the CPS. When microphone PTT is sensed, the μ P will always configure the ASFIC CMP for the "internal" mic audio path, and external PTT will result in the external mic audio path being selected.

Inside the ASFIC CMP, the mic audio is filtered to eliminate frequency components outside the 300-3000Hz voice band, and pre-emphasized if pre-emphasis is enabled. The signal is then limited to prevent the transmitter from over deviating. The limited mic audio is then routed through a summer, which is used to add in signalling data, and then to a splatter filter to eliminate high frequency spectral components that could be generated by the limiter. The audio is then routed to an attenuator, which is tuned in the factory or the field to set the proper amount of FM deviation. The TX audio emerges from the ASFIC CMP at U0221-40 MOD IN, at which point it is routed to the RF section.

Dependent on the radio model, input pin 3 on the accessory connector can be programmed for DATA PTT by the CPS. When DATA PTT is sensed, the μ P will always configure the ASFIC CMP for the flat TX audio path. Limiter and any filtering will be disabled. The signal is routed directly to the attenuator, which sets the FM deviation according to the channel spacing of the active transmit channel and emerges from the ASFIC CMP at U0221-40, at which point it is routed to the RF section.

2.2.3 TX Secure Audio (optional)

The audio follows the normal transmit audio processing until it emerges from the ASFIC CMP TX SND pin (U0221-44), which is fed to the Secure board residing at option connector J0551-33. The

Secure board contains circuitry to amplify, encrypt, and filter the audio. The encrypted signal is then fed back from J0551-32 to the ASFIC CMP TX RTN input (U0221-36). The signal level at this pin should be about 65mVrms. The signal is then routed through the TX path in the ASFIC CMP and emerges at MOD IN pin 40.

2.2.4 Option Board Transmit Audio

The audio follows the normal transmit audio processing until it emerges from the ASFIC CMP TX SND pin (U0221-44), which is fed to the option board residing at option connector J0551-33. The option board contains circuitry to process the audio. The processed signal is then fed back from J0551-32 to the ASFIC CMP TX RTN input (U0221-36). The signal level at this pin should be about 65mVrms. The signal is then routed through the TX path in the ASFIC CMP and emerges at MOD IN pin 40.

2.3 Transmit Signalling Circuits

Refer to Figure 4-1 for reference for the following sections.

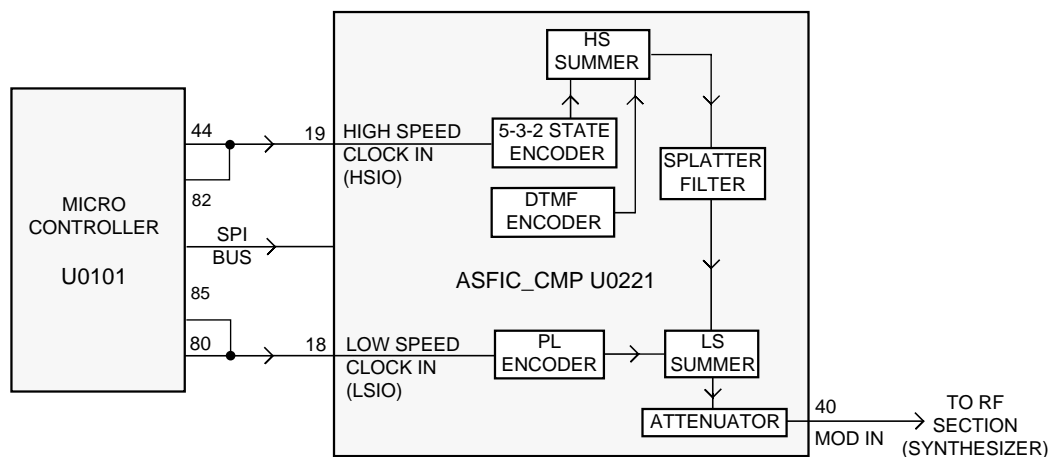

Figure 4-1 Transmit Signalling Paths

From a hardware point of view, there are 3 types of signalling:

- 1) sub-audible data (PL / DPL / Connect Tone) that gets summed with transmit voice or signalling,
- 2) DTMF data for telephone communication in trunked and conventional systems, and
- 3) Audible signalling including Select 5, MPT-1327, MDC, High speed Trunking.

NOTE: All three types are supported by the hardware while the radio software determines which signalling type is available.

2.3.1 Sub-audible Data (PL/DPL)

Sub-audible data implies signalling whose bandwidth is below 300Hz. PL and DPL waveforms are used for conventional operation and connect tones for trunked voice channel operation. The trunking connect tone is simply a PL tone at a higher deviation level than PL in a conventional system. Although it is referred to as "sub-audible data," the actual frequency spectrum of these waveforms

may be as high as 250 Hz, which is audible to the human ear. However, the radio receiver filters out any audio below 300Hz, so these tones are never heard in the actual system.

Only one type of sub-audible data can be generated by U0221 (ASFIC CMP) at any one time. The process is as follows, using the SPI BUS, the μ P programs the ASFIC CMP to set up the proper low-speed data deviation and select the PL or DPL filters. The μ P then generates a square wave which strobes the ASFIC PL / DPL encode input LSIO U0221-18 at twelve times the desired data rate. For example, for a PL frequency of 103Hz, the frequency of the square wave would be 1236Hz.

This drives a tone generator inside U0221 which generates a staircase approximation to a PL sine wave or DPL data pattern. This internal waveform is then low-pass filtered and summed with voice or data. The resulting summed waveform then appears on U0221-40 (MOD IN), where it is sent to the RF board as previously described for transmit audio. A trunking connect tone would be generated in the same manner as a PL tone.

2.3.2 High Speed Data

High speed data refers to the 3600 baud data waveforms, known as Inbound Signalling Words (ISWs) used in a trunking system for high speed communication between the central controller and the radio. To generate an ISW, the μ P first programs the ASFIC CMP (U0221) to the proper filter and gain settings. It then begins strobing U0221-19 (HSIO) with a pulse when the data is supposed to change states. U0221's 5-3-2 State Encoder (which is in a 2-state mode) is then fed to the post-limiter summer block and then the splatter filter. From that point it is routed through the modulation attenuators and then out of the ASFIC CMP to the RF board. MPT 1327 and MDC are generated in much the same way as Trunking ISW. However, in some cases these signals may also pass through a data pre-emphasis block in the ASFIC CMP. Also these signalling schemes are based on sending a combination of 1200 Hz and 1800 Hz tones only. Microphone audio is muted during High Speed Data signalling.

2.3.3 Dual Tone Multiple Frequency (DTMF) Data

DTMF data is a dual tone waveform used during phone interconnect operation. It is the same type of tones which are heard when using a "Touch Tone" telephone.

There are seven frequencies, with four in the low group (697, 770, 852, 941Hz) and three in the high group (1209, 1336, 1477Hz).

The high-group tone is generated by the μ P (U0101-44) strobing U0221-19 at six times the tone frequency for tones less than 1440Hz or twice the frequency for tones greater than 1440Hz. The low group tone is generated by the ASFIC CMP, controlled by the μ P via SPI bus. Inside U0221 the low-group and high-group tones are summed (with the amplitude of the high group tone being approximately 2 dB greater than that of the low group tone) and then pre-emphasized before being routed to the summer and splatter filter. The DTMF waveform then follows the same path as was described for high-speed data.

2.4 Receive Audio Circuits

Refer to Figure5-5 for reference for the following sections.

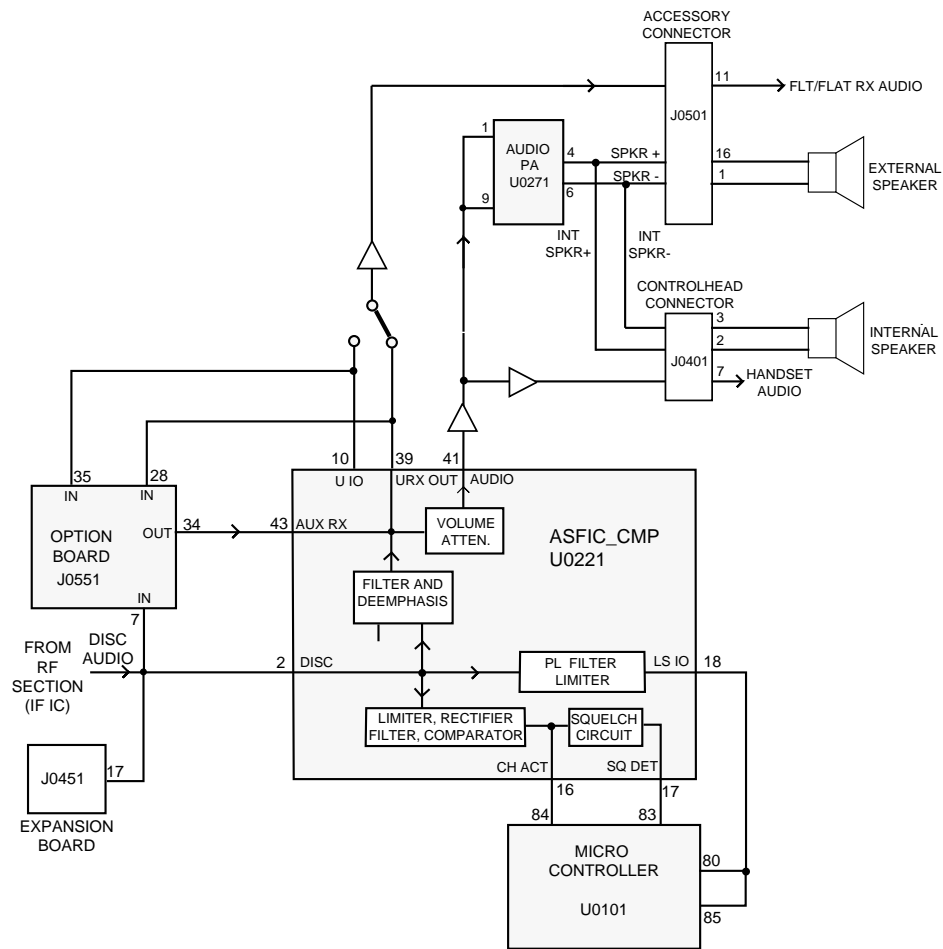

Figure 4-1 Receive Audio Paths

2.4.1 Squelch Detect

The radio's RF circuits are constantly producing an output at the discriminator (IF IC). This signal (DISC AUDIO) is routed to the ASFIC CMP's squelch detect circuitry input DISC (U0221-2). All of the squelch detect circuitry is contained within the ASFIC CMP. Therefore from a user's point of view, DISC AUDIO enters the ASFIC CMP, and the ASFIC CMP produces two CMOS logic outputs based on the result. They are CH ACT (U0221-16) and SQ DET (U0221-17).

The squelch signal entering the ASFIC CMP is amplified, filtered, attenuated, and rectified. It is then sent to a comparator to produce an active high signal on CH ACT. A squelch tail circuit is used to produce SQ DET (U0221-17) from CH ACT. The state of CH ACT and SQ DET is high (logic 1) when carrier is detected, otherwise low (logic 0).

CH ACT is routed to the μ P pin 84 while SQ DET is routed to the μ P pin 83.

SQ DET is used to determine all audio mute / unmute decisions except for Conventional Scan. In this case CH ACT is a pre-indicator as it occurs slightly faster than SQ DET.

2.4.2 Audio Processing and Digital Volume Control

The receiver audio signal enters the controller section from the IF IC on DISC AUDIO. The signal is DC coupled by R0228 and enters the ASFIC CMP via the DISC pin U0221-2.

Inside the ASFIC CMP, the signal goes through 2 paths in parallel, the audio path and the PL/DPL path.

The audio path has a programmable amplifier, whose setting is based on the channel bandwidth being received, then a LPF filter to remove any frequency components above 3000Hz and then an HPF to strip off any sub-audible data below 300Hz. Next, the recovered audio passes through a de-emphasis filter if it is enabled (to compensate for Pre-emphasis which is used to reduce the effects of FM noise). The IC then passes the audio through the 8-bit programmable attenuator whose level is set depending on the value of the volume control. Finally the filtered audio signal passes through an output buffer within the ASFIC CMP. The audio signal exits the ASFIC CMP at pin AUDIO (U0221-41).

The μ P programs the attenuator, using the SPI BUS, based on the volume setting. The minimum / maximum settings of the attenuator are set by codeplug parameters.

Since sub-audible signalling is summed with voice information on transmit, it must be separated from the voice information before processing. Any sub-audible signalling enters the ASFIC CMP from the IF IC at DISC U0221-2. Once inside it goes through the PL/DPL path. The signal first passes through one of 2 low pass filters, either PL low pass filter or DPL/LST low pass filter. Either signal is then filtered and goes through a limiter and exits the ASFIC CMP at LSIO (U0221-18). At this point the signal will appear as a square wave version of the sub-audible signal which the radio received. The microprocessor U0101-80 will decode the signal directly to determine if it is the tone / code which is currently active on that mode.

2.4.3 Audio Amplification Speaker (+) Speaker (-)

The output of the ASFIC CMP's digital volume pot, U0221-41 is routed through dc blocking capacitor C0265 to a buffer formed by U0211-1. Resistors R0265 and R0268 set the correct input level to the audio PA (U0271). This is necessary because the gain of the audio PA is 46 dB, and the ASFIC CMP output is capable of overdriving the PA unless the maximum volume is limited. Resistor R0267 and capacitor C0267 increase frequency components below 350 Hz.

The audio then passes through R0269 and C0272 which provides AC coupling and low frequency roll-off. C0273 provides high frequency roll-off as the audio signal is routed to pins 1 and 9 of the audio power amplifier U0271.

The audio power amplifier has one inverted and one non-inverted output that produces the differential audio output SPK+ / SPK- (U0271-4/6). The inputs for each of these amplifiers are pins 1 and 9 respectively; these inputs are both tied to the received audio. The audio PA's DC biases are not activated until the audio PA is enabled at pin 8.

The audio PA is enabled via the ASFIC CMP (U0221-38). When the base of Q0271 is low, the transistor is off and U0271-8 is high, using pull up resistor R0273, and the Audio PA is ON. The voltage at U0273-8 must be above 8.5VDC to properly enable the device. If the voltage is between 3.3 and 6.4V, the device will be active but has its input (U0273-1/9) off. This is a mute condition which is used to prevent an audio pop when the PA is enabled.

The SPK+ and SPK- outputs of the audio PA have a DC bias which varies proportionately with FLT A+ (U0271-7). FLT A+ of 11V yields a DC offset of 5V, and FLT A+ of 17V yields a DC offset of 8.5V. If either of these lines is shorted to ground, it is possible that the audio PA will be damaged. SPK+ and SPK- are routed to the accessory connector (J0501-16 and 1) and to the controlhead (connector J0401-2 and 3).

2.4.4 Handset Audio

Certain hand held accessories have a speaker within them which require a different voltage level than that provided by U0271. For those devices HANDSET AUDIO is available at controlhead connector J0401-7.

The received audio from the output of the ASFIC CMP's digital volume attenuator and buffered by U0211-1 is also routed to U0211-3 pin 9 where it is amplified 20 dB; this is set by the 10k/100k combination of R0261 and R0262. This signal is routed from the output of the op amp U0211-3 pin 8 to J0401-7. The controlhead sends this signal directly out to the microphone jack. The maximum value of this output is 6.6Vp-p.

2.4.5 Filtered Audio and Flat Audio

The ASFIC CMP has an audio whose output at U0221-39 has been filtered and de-emphasized, but has not gone through the digital volume attenuator. From ASFIC CMP U0221-39 the signal is routed via R0251 through gate U0251-12 and AC coupled to U0211-2. The gate controlled by ASFIC CMP port GCB3 (U0221-35) selects between the filtered audio signal from the ASFIC CMP pin 39 (URXOUT) or the unfiltered (flat) audio signal from the ASFIC CMP pin 10 (UIO). R0251 and R0253 determine the gain of op-amp U0211-2 for the filtered audio while R0252 and R0253 determine the gain for the flat Audio. The output of U0253-7 is then routed to J0501-11 via dc blocking capacitor C0542 and R0531. Note that any volume adjustment of the signal on this path must be done by the accessory

2.4.6 RX Secure Audio (optional)

Discriminator audio, which is now encrypted audio, follows the normal receive audio processing until it emerges from the ASFIC CMP UIO pin (U0221-10), which is fed to the Secure board residing at option connector J0551-35. On the Secure board, the encrypted signal is converted back to normal audio format, and then fed back through (J0551-34) to AUX RX of the ASFIC CMP (U0221-43). From then on it follows a path identical to conventional receive audio, where it is filtered (0.3 - 3kHz) and de-emphasized. The signal URX SND from the ASFIC CMP (U0221-39), also routed to option connector J0551-28, is not used for the Secure board but for other option boards.

2.4.7 Option Board Receive Audio

Unfiltered audio from the ASFIC CMP pin UIO (U0221-10) enters the option board at connector J0551-35. Filtered audio from the ASFIC CMP pin URXOUT (U0221-39) enters the option board at connector J0551-28. On the option board, the signal may be processed, and then fed back through J0551-34 to AUX RX of the ASFIC CMP (U0221-43). From then on it follows a path identical to conventional receive audio, where it may be filtered (0.3 - 3kHz) and de-emphasized.

2.5 RECEIVE SIGNALLING CIRCUITS

Refer to Figure 5-6 for reference for the following sections.

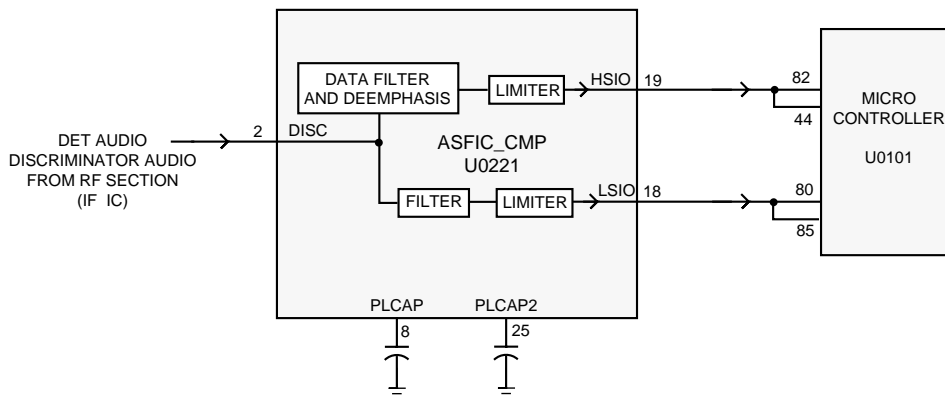

Figure 4-2 Receive Signalling Paths

2.5.1 Sub-audible (PL/DPL) and High Speed Data Decoder

The ASFIC CMP (U0221) is used to filter and limit all received data. The data enters the ASFIC CMP at input DISC (U0221-2). Inside U0221 the data is filtered according to data type (HS or LS), then it is limited to a 0-5V digital level. The MDC and trunking high speed data appear at U0221-19, where it connects to the μ P U0101-82

The low speed limited data output (PL, DPL, and trunking LS) appears at U0221-18, where it connects to the μ P U0101-80.

The low speed data is read by the μ P at twice the frequency of the sampling waveform; a latch configuration in the ASFIC CMP stores one bit every clock cycle. The external capacitors C0236, and C0244 set the low frequency pole for a zero crossings detector in the limiters for PL and HS data. The hysteresis of these limiters is programmed based on the type of received data.

2.5.2 Alert Tone Circuits

When the software determines that it needs to give the operator an audible feedback (for a good key press, or for a bad key press), or radio status (trunked system busy, phone call, circuit failures), it sends an alert tone to the speaker. It does so by sending SPI BUS data to U0221 which sets up the audio path to the speaker for alert tones. The alert tone itself can be generated in one of two ways: internally by the ASFIC CMP, or externally using the μ P and the ASFIC CMP.

The allowable internal alert tones are 304, 608, 911, and 1823Hz. In this case a code contained within the SPI BUS load to the ASFIC CMP sets up the path and determines the tone frequency, and at what volume level to generate the tone. (It does not have to be related to the voice volume setting).

For external alert tones, the μ P can generate any tone within the 100-3000Hz audio band. This is accomplished by the μ P generating a square wave which enters the ASFIC CMP at U0221-19. Inside the ASFIC CMP this signal is routed to the alert tone generator

The output of the generator is summed into the audio chain just after the RX audio de-emphasis block. Inside U0221 the tone is amplified and filtered, then passed through the 8-bit digital volume attenuator, which is typically loaded with a special value for alert tone audio. The tone exits at U0221-41 and is routed to the audio PA like receive audio

2.6 Voice Storage (optional)

The Voice Storage (VS) option can be used to store audio signals coming from the receiver or from the microphone. Any stored audio signal can be played back over the radio's speaker or sent out via the radio's transmitter.

The Voice Storage option can be placed on the controller section or on an additional option board which resides on option board connector J0551. Voice Storage IC U0301 provides all required functionality and is powered from 3.3 volts regulator U0351 which, is powered from the regulated 5 volts. Dual shottky diode D0301 reduces the supply voltage for U0301 to 3 volts. The microprocessor controls U0301 via SPI bus lines CLK (U0301-8), DATA (U0301-10) and MISO (U0301-11). To transfer data, the μ P first selects the U0301 via address decoder U0141, line VS CS and U0301 pin 9. Then the μ P sends data through line DATA and receives data through line MISO. Pin 2 (RAC) of U0301 indicates the end of a message row by a low state for 12.5 ms and connects to μ P pin 52. A low at pin 5 (INT), which is connected to μ P pin 55 indicates that the Voice Storage IC requires service from the μ P.

Audio, either from the radio's receiver or from one of the microphone inputs, emerges the ASFIC CMP (U0221) at pin 39, is buffered by op-amp U0341-1 and enters the Voice Storage IC U0301 at pin 25. During playback, the stored audio emerges U0301 at pin 20. To transmit the audio signal it is fed through resistive divider R0344 / R0345 and line VS MIC to input selector IC U0251. When this path is selected by the μ P via ASFIC CMP port GCB 4, the audio signal enters the ASFIC CMP at pin 48 and is processed like normal transmit audio. To play the stored audio over the radio's speaker, the audio from U0301 pin 20 is buffered by op-amp U0341-2 and fed via switch U0342 and line FLAT RX SND to ASFIC CMP pin 10 (UIO). In this case, this ASFIC CMP pin is programmed as input and feeds the audio signal through the normal receiver audio path to the speaker or handset. Switch U0342 is controlled by the μ P via ASFIC CMP port GCB 4 and feeds the stored audio only to the ASFIC CMP port UIO when it is programmed as input.

TROUBLESHOOTING CHARTS

1.0 Controller Troubleshooting Chart

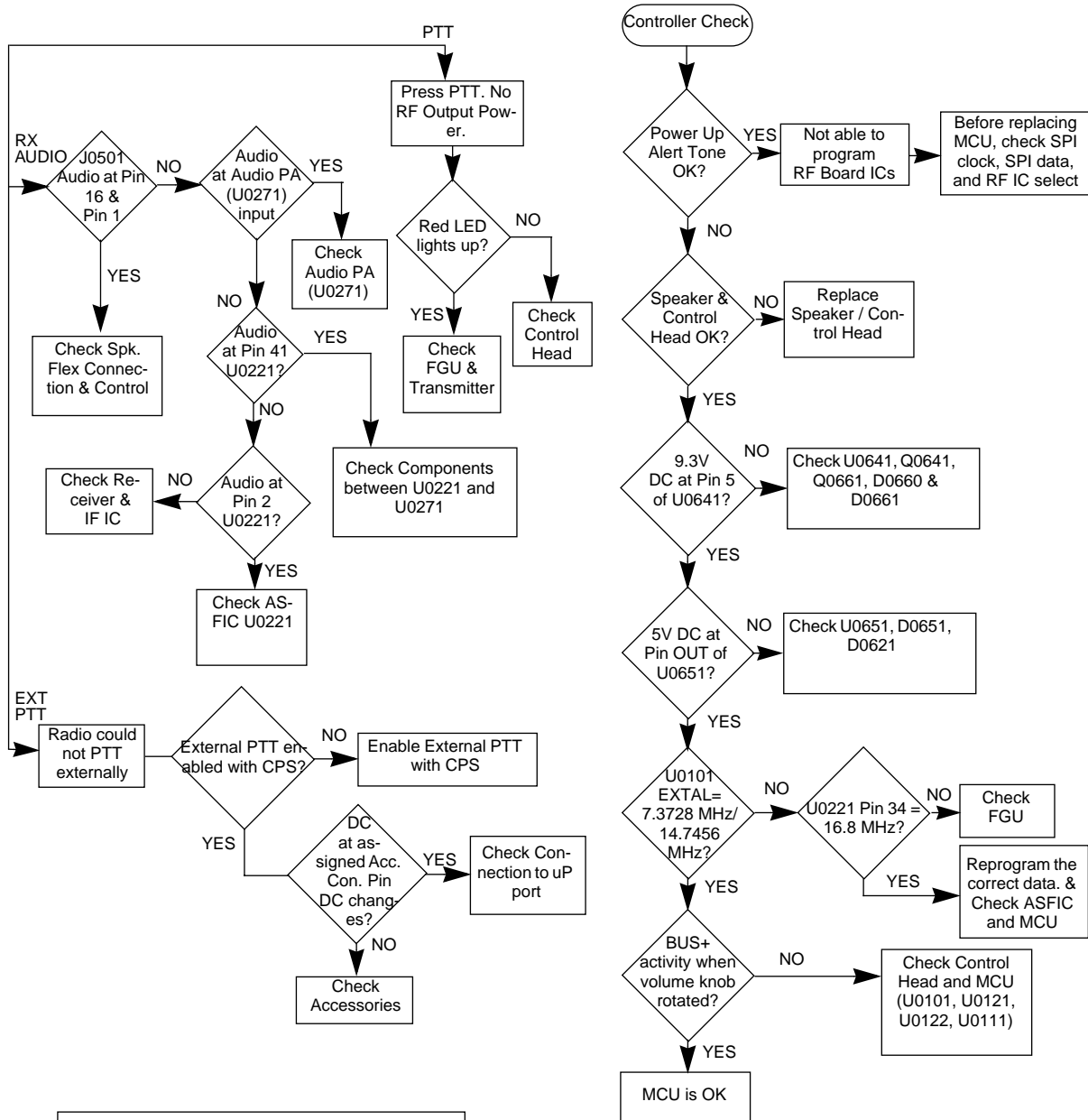

Before troubleshooting the controller section according to this chart please check the following:

1. Check tuning and CPS settings
2. Check if Alert Tones are enabled
3. Check if Control Head is OK
4. Check board visually

CONTROLLER SCHEMATICS / PARTS LIST

1.0 Allocation of Schematics and Circuit Boards

1.1 Controller Circuits

This Chapter shows the Schematics and the the Parts Lists for the Controller circuits.

1.2 Voice Storage Facility

The Voice Storage is fitted on all MPT radios GM640/660/1280 and on GM380 as standard. The schematics, component layout and parts list for these circuits are shown in this chapter. The Voice Storage schematic is shown in Tables below.

Table 3-1 Controller T2 Diagrams and Parts Lists

Controller T2 used on PCB : 8486172B04 VHF, 1-25W	
SCHEMATICS	
Controller Overall	Page 3-3
Supply Voltage	Page 3-4
Audio	Page 3-5
I/O	Page 3-6
Microprocessor	Page 3-7
Parts List	
Controller T2	Page 3-8

Table 3-2 Controller T5 Diagrams and Parts Lists

Controller T5 used on PCB : 8486172B06 VHF, 1-25W	
SCHEMATICS	
Controller Overall	Page 3-10
Supply Voltage	Page 3-11
Audio	Page 3-12
I/O	Page 3-13
Microprocessor	Page 3-14
Voice Storage (if fitted)	Page 3-15
Parts List	
Controller T5	Page 3-16

Table 3-3 Controller T6/T7 Diagrams and Parts Lists

Controller T6/T7 used on PCB : T6 on 8486206B06 LB1, 25-60W T6 on 8486207B05 LB2, 25-60W T6 on 8486140B12 VHF, 25-45W T6 on 8480643z06 UHF B1, 25-40W T7 on 8486172B07 VHF, 1-25W T7 on 8485670z02 UHF B1, 1-25W	
SCHEMATICS Controller Overall Supply Voltage Audio I/O T6 I/O T7 Microprocessor Voice Storage (if fitted)	Page 3-18 Page 3-19 Page 3-20 Page 3-21 Page 3-22 Page 3-23 Page 3-24
Parts List Controller T6/T7	Page 3-25

Table 3-4 Controller T9 Diagrams and Parts Lists

Controller T9 used on PCB : 8486172B08 VHF, 1-25W 8485670z03 UHF B1, 1-25W	
SCHEMATICS Controller Overall Supply Voltage Audio I/O Microprocessor Voice Storage (if fitted)	Page 3-27 Page 3-28 Page 3-29 Page 3-30 Page 3-31 Page 3-32
Parts List Controller T9	Page 3-33

2.0 Controller T2 / Schematic Diagrams

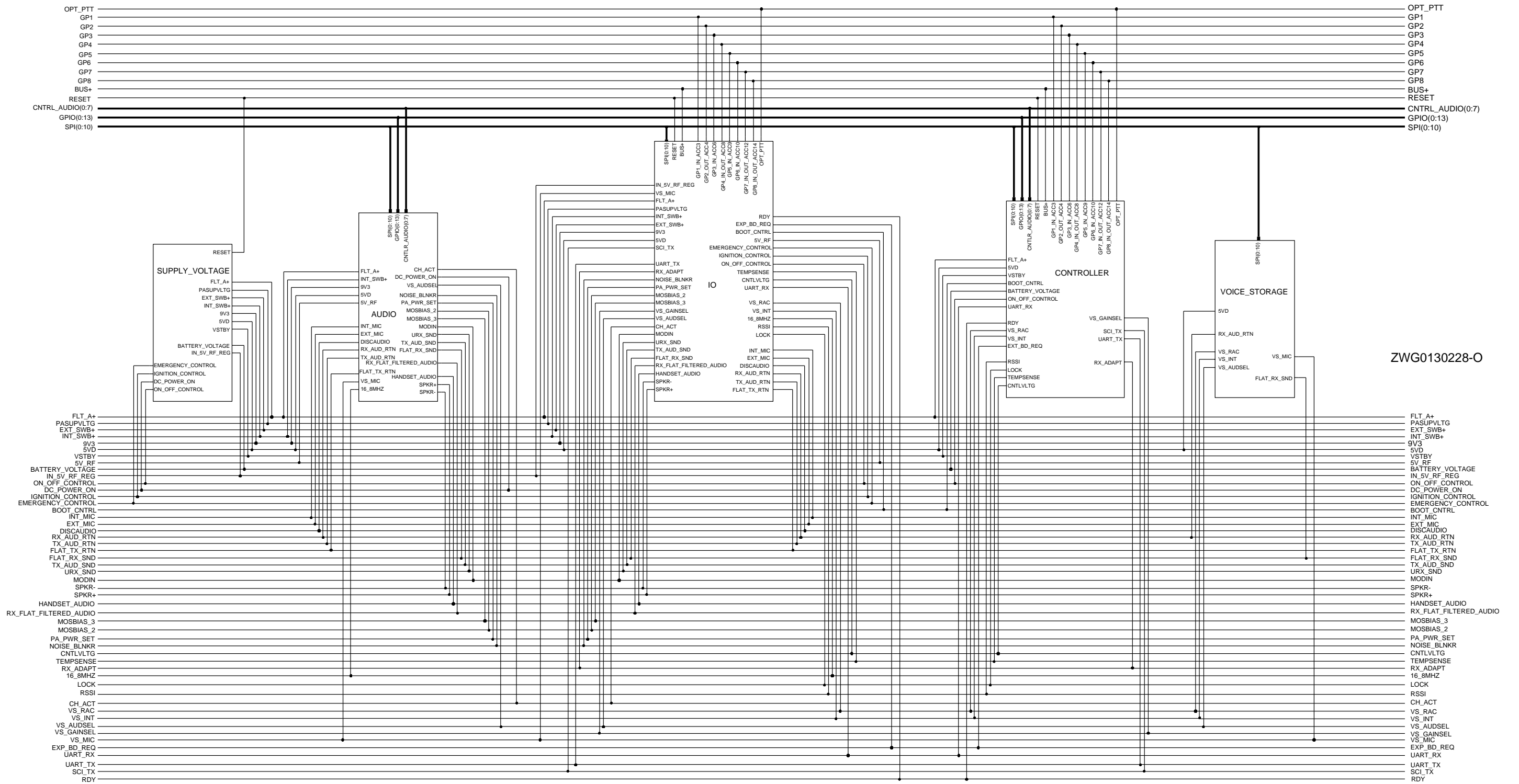

Controller T2 Schematic Diagram - Controller Overall

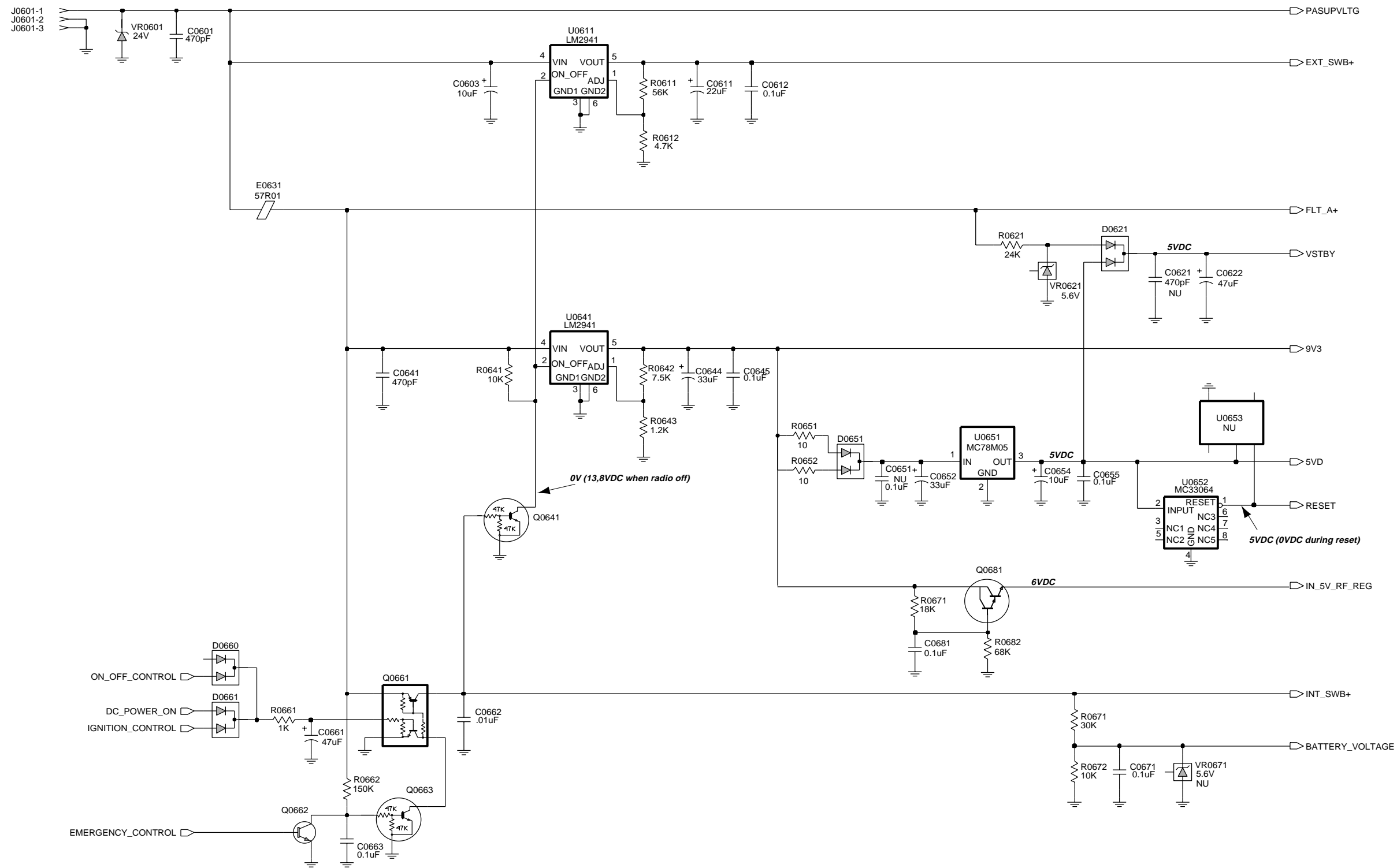

ZWG01300232-A

Controller T2 Schematic Diagram - Supply Voltage

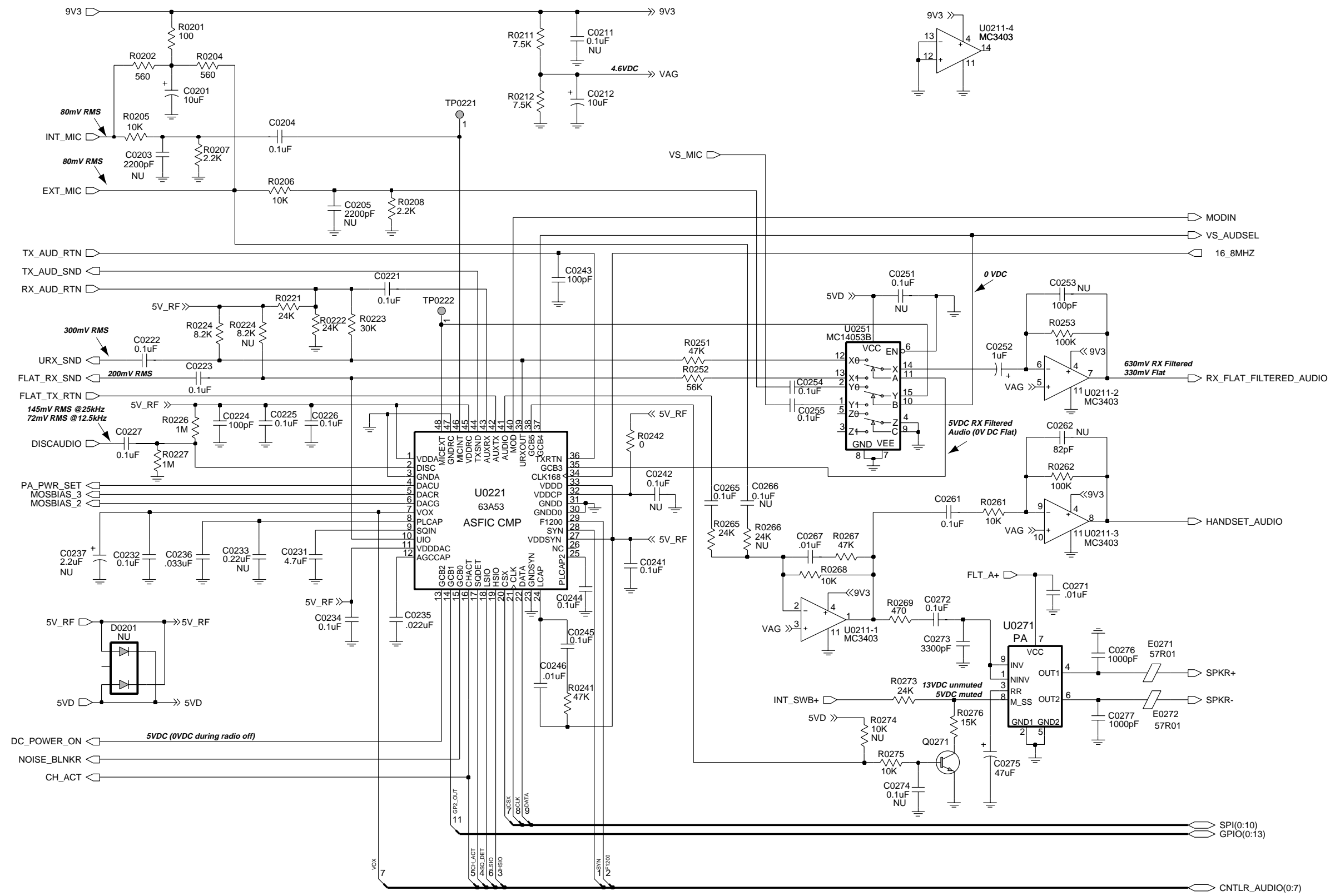

ZWG0130231-A

ControllerT2 Schematic Diagram - Audio

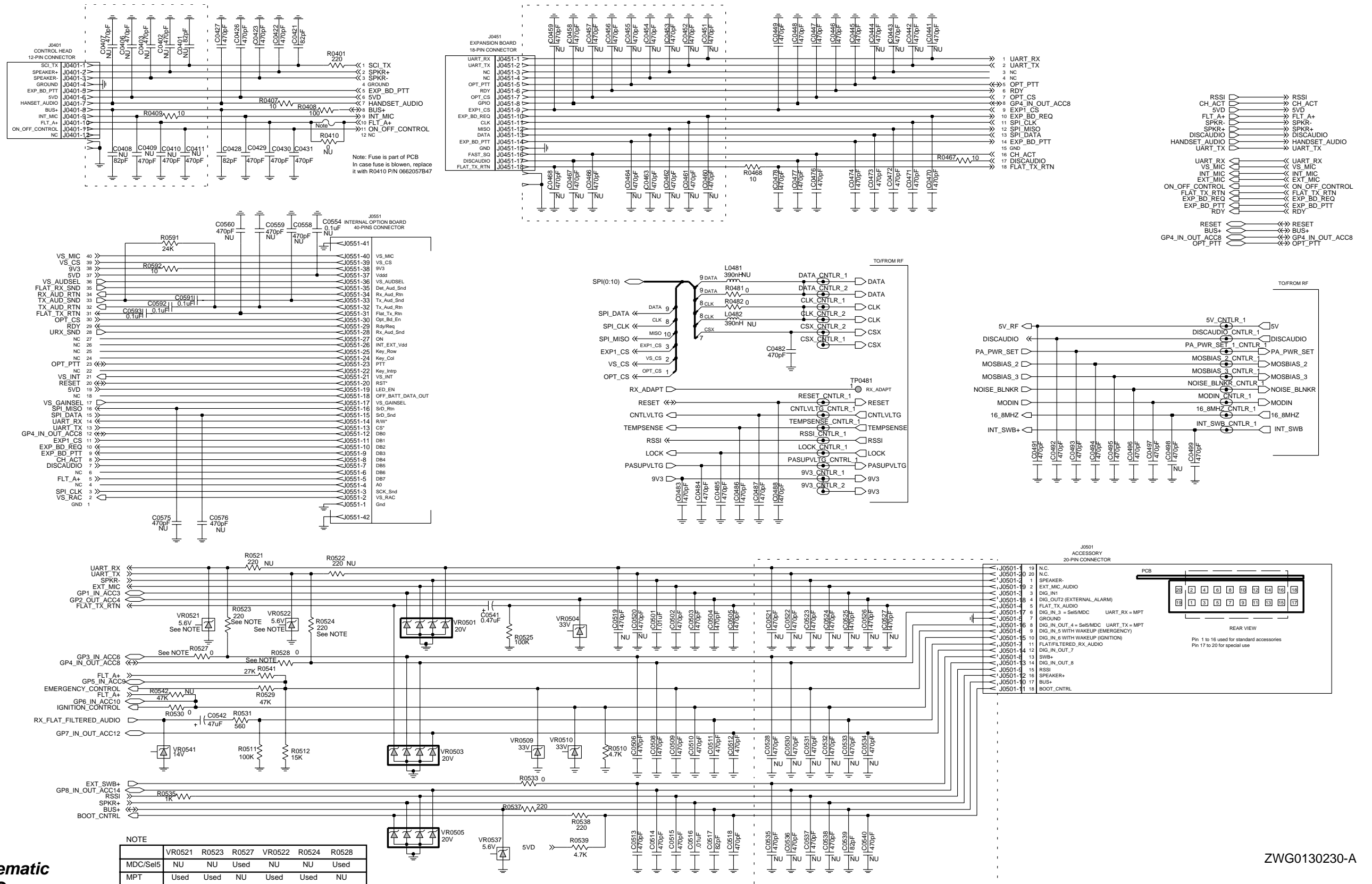

Controller T2 Schematic Diagram - IO

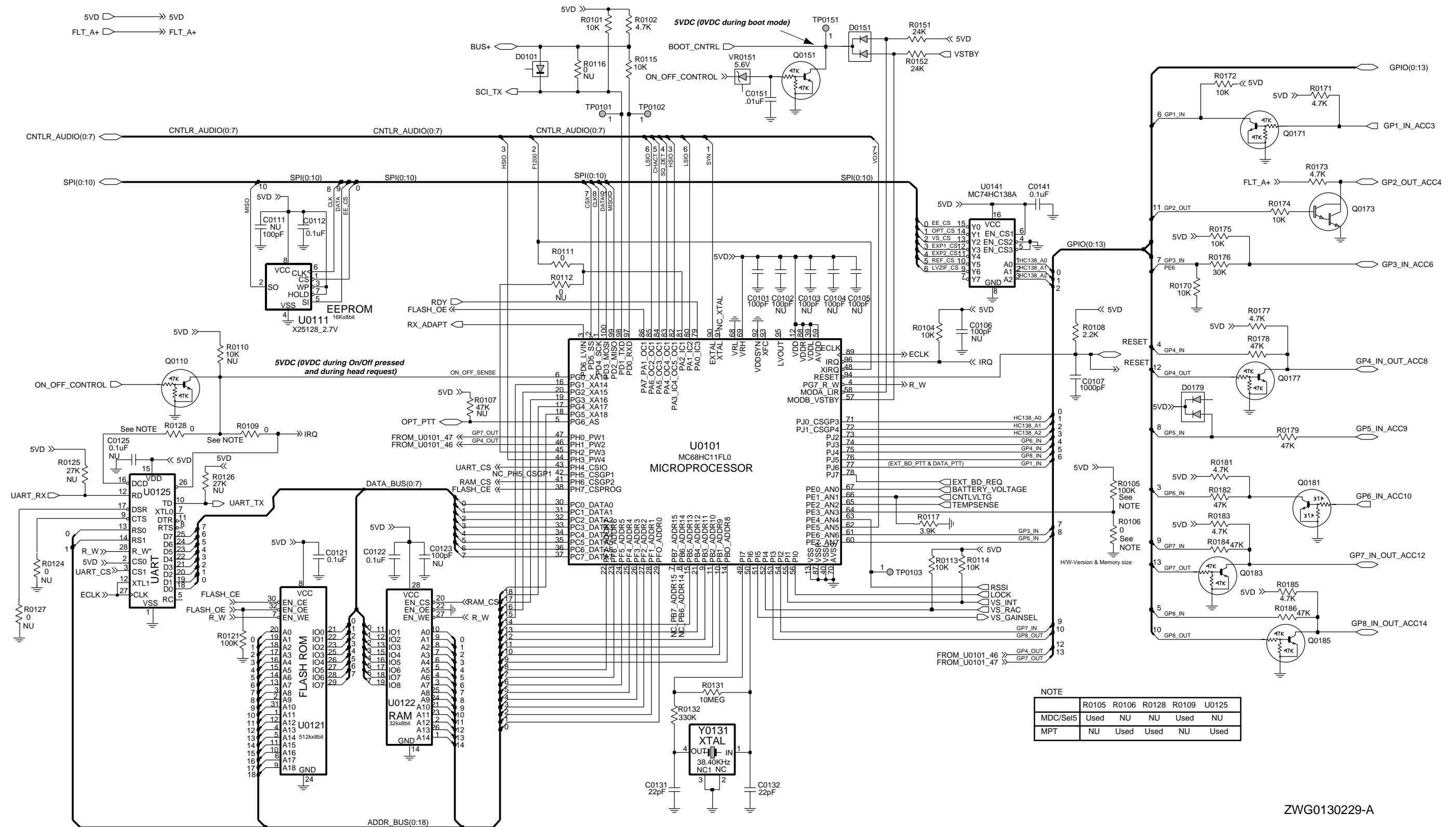

Controller T2 Schematic Diagram - Microprocessor

2.1 Controller T2 Parts List

Circuit Ref	Motorola Part No.	Description
C0101	2113740F51	100pF
C0107	2113741F25	1000pF
C0112	2113743E20	0.1uF
C0121	2113743E20	0.1uF
C0122	2113743E20	0.1uF
C0125	2113743E20	0.1uF
C0131	2113740F35	22pF
C0132	2113740F35	22pF
C0141	2113743E20	0.1uF
C0151	2113741F49	.01uF
C0201	2311049A57	10uF
C0204	2113743E20	0.1uF
C0212	2311049A57	10uF
C0221	2113743E20	0.1uF
C0222	2113743E20	0.1uF
C0223	2113743E20	0.1uF
C0224	2113740F51	100pF
C0225	2113743E20	0.1uF
C0226	2113743E20	0.1uF
C0227	2113743E20	0.1uF
C0231	2113743G24	2.2uF
C0232	2113743E20	0.1uF
C0234	2113743E20	0.1uF
C0235	2113743E07	.022uF
C0236	2113743E10	.033uF
C0241	2113743E20	0.1uF
C0243	2113740F51	100pF
C0244	2113743E20	0.1uF
C0245	2113743E20	0.1uF
C0246	2113741F49	.01uF
C0252	2311049A07	1uF
C0254	2113743E20	0.1uF
C0255	2113743E20	0.1uF
C0261	2113743E20	0.1uF
C0262	2113740F49	82pF
C0265	2113743E20	0.1uF
C0267	2113741F49	.01uF

Circuit Ref	Motorola Part No.	Description
C0271	2113741F49	.01uF
C0272	2113743E20	0.1uF
C0273	2113741F37	3300pF
C0275	2311049A99	47uF
C0276	2113741F25	1000pF
C0277	2113741F25	1000pF
C0421	2113743N48	82pF
C0422	2113741F17	470pF
C0423	2113741F17	470pF
C0426	2113743L09	470pF
C0427	2113743L09	470pF
C0428	2113743N48	82pF
C0429	2113743L09	470pF
C0430	2113741F17	470pF
C0431	2113741F17	470pF
C0441	2113743L09	470pF
C0442	2113743L09	470pF
C0445	2113743L09	470pF
C0446	2113743L09	470pF
C0447	2113743L09	470pF
C0448	2113743L09	470pF
C0449	2113743L09	470pF
C0470	2113743L09	470pF
C0471	2113743L09	470pF
C0472	2113743L09	470pF
C0473	2113743L09	470pF
C0474	2113743L09	470pF
C0476	2113743L09	470pF
C0477	2113743L09	470pF
C0478	2113743L09	470pF
C0482	2113743L09	470pF
C0483	2113743L09	470pF
C0484	2113741F17	470pF
C0485	2113743L09	470pF
C0486	2113743L09	470pF
C0487	2113743L09	470pF
C0488	2113743L09	470pF
C0490	2113743L09	470pF

Circuit Ref	Motorola Part No.	Description
C0491	2113743L09	470pF
C0492	2113743L09	470pF
C0493	2113743L09	470pF
C0494	2113743L09	470pF
C0495	2113743L09	470pF
C0496	2113743L09	470pF
C0497	2113743L09	470pF
C0499	2113743L09	470pF
C0501	2113741F49	.01uF
C0502	2113743L09	470pF
C0503	2113743L09	470pF
C0504	2113743L09	470pF
C0505	2113743L09	470pF
C0506	2113743L09	470pF
C0508	2113743L09	470pF
C0509	2113743L09	470pF
C0510	2113741F17	470pF
C0511	2113743L09	470pF
C0512	2113743L09	470pF
C0513	2113741F17	470pF
C0514	2113743L09	470pF
C0515	2113743L09	470pF
C0516	2113741F49	.01uF
C0517	2113743N48	82pF
C0518	2113743L09	470pF
C0541	2311049A05	0.47uF
C0542	2311049A99	47uF
C0591	2113743E20	0.1uF
C0592	2113743E20	0.1uF
C0593	2113743E20	0.1uF
C0601	2113741F17	470pF
C0603	2380090M24	10uF
C0611	2311049C06	22uF
C0612	2113743E20	0.1uF
C0622	2311049A99	47uF
C0641	2113741F17	470pF
C0644	2311049A97	33uF
C0645	2113743E20	0.1uF

Circuit Ref	Motorola Part No.	Description
C0652	2311049A97	33uF
C0654	2311049A57	10uF
C0655	2113743E20	0.1uF
C0661	2311049C05	47uF
C0662	2113741F49	.01uF
C0663	2113743E20	0.1uF
C0671	2113743E20	0.1uF
C0681	2113743E20	0.1uF
D0101	4880236E05	
D0151	4813833C02	
D0179	4813833C02	
D0621	4813833C02	
D0651	4813833C02	
D0660	4813833C02	
D0661	4813833C02	
E0271	2484657R01	57R01
E0272	2484657R01	57R01
E0631	2484657R01	
J0401	0902636Y02	
J0451	0902636Y01	
J0501	0986105B01	
J0551	0905505Y04	
J0601	0986165B01	
Q0110	4880048M01	
Q0151	4880048M01	
Q0171	4880048M01	
Q0173	4880052M01	
Q0177	4880048M01	
Q0181	4880048M01	
Q0183	4880048M01	
Q0185	4880048M01	
Q0271	4813824A10	
Q0641	4880048M01	
Q0661	4805921T02	
Q0662	4813824A10	
Q0663	4880048M01	
Q0681	4880052M01	
R0101	0662057A73	10K

Circuit Ref	Motorola Part No.	Description
R0102	0662057A65	4.7K
R0104	0662057A73	10K
R0105	0662057A97	100K
R0108	0662057A57	2.2K
R0111	0662057B47	0
R0113	0662057A73	10K
R0114	0662057A73	10K
R0115	0662057A73	10K
R0117	0662057A63	3.9K
R0121	0662057A97	100K
R0124	0662057B47	0
R0125	0662057A83	27K
R0126	0662057A83	27K
R0127	0662057B47	0
R0128	0662057B47	0
R0131	0662057B46	10MEG
R0132	0662057B10	330K
R0151	0662057A82	24K
R0152	0662057A82	24K
R0170	0662057A73	10K
R0171	0662057A65	4.7K
R0172	0662057A73	10K
R0173	0662057A65	4.7K
R0174	0662057A73	10K
R0175	0662057A73	10K
R0176	0662057A84	30K
R0177	0662057A65	4.7K
R0178	0662057A89	47K
R0179	0662057A89	47K
R0181	0662057A65	4.7K
R0182	0662057A89	47K
R0183	0662057A65	4.7K
R0184	0662057A89	47K
R0185	0662057A65	4.7K
R0186	0662057A89	47K
R0201	0662057A25	100
R0202	0662057A43	560
R0204	0662057A43	560

Circuit Ref	Motorola Part No.	Description
R0205	0662057A73	10K
R0206	0662057A73	10K
R0207	0662057A57	2.2K
R0208	0662057A57	2.2K
R0211	0660076E70	7.5K
R0212	0660076E70	7.5K
R0221	0662057A82	24K
R0222	0662057A82	24K
R0223	0662057A84	30K
R0224	0662057A71	8.2K
R0226	0662057B22	1MEG
R0227	0662057B22	1MEG
R0241	0662057A89	47K
R0242	0662057B47	0
R0251	0662057A89	47K
R0252	0662057A91	56K
R0253	0662057A97	100K
R0261	0662057A73	10K
R0262	0662057A97	100K
R0265	0662057A82	24K
R0267	0662057A89	47K
R0268	0662057A73	10K
R0269	0662057A41	470
R0273	0662057A82	24K
R0275	0662057A73	10K
R0276	0662057A77	15K
R0401	0662057A33	220
R0407	0662057M26	10
R0408	0662057A25	100
R0409	0662057M26	10
R0467	0662057M26	10
R0468	0662057M26	10
R0481	0662057B47	0
R0482	0662057B47	0
R0510	0662057A65	4.7K
R0511	0662057A97	100K
R0512	0662057A77	15K
R0523	0662057A33	220

Circuit Ref	Motorola Part No.	Description
R0524	0662057A33	220
R0525	0662057A97	100K
R0529	0662057A89	47K
R0530	0662057B47	0
R0531	0662057A43	560
R0533	0662057B47	0
R0535	0662057A49	1K
R0537	0662057A33	220
R0538	0662057A33	220
R0539	0662057A65	4.7K
R0541	0662057A83	27K
R0591	0662057A82	24K
R0592	0662057A01	10
R0611	0662057A91	56K
R0612	0662057A65	4.7K
R0621	0662057A82	24K
R0641	0662057A73	10K
R0642	0660076E70	7.5K
R0643	0660076E51	1.2K
R0651	0662057A01	10
R0652	0662057A01	10
R0661	0662057A49	1K
R0662	0662057B02	150K
R0671	0662057A84	30K
R0672	0662057A73	10K
R0681	0662057A79	18K
R0682	0662057A93	68K
U0101	5102226J56	MC68HC11FL0
* U0111	5102463J64	X25128-2.7
* U0121	5186137B01	AT49F040
U0122	5185963A21	63A21
U0125	5105625U34	CDP65C51A
U0141	5113805A30	MC74HC138A
U0211	5183222M49	MC3403
U0221	5185963A53	63A53
U0251	5113806A20	MC14053B
U0271	5109699X01	TDA1519C
U0611	5183308X01	LM2941

Circuit Ref	Motorola Part No.	Description
U0641	5183308X01	LM2941
U0651	5113816A07	MC78M05
U0652	5113815A02	MC33064
U0653	4805921T02	NU
VR0151	4813830A15	5.6V
VR0501	4805656W09	20V
VR0503	4805656W09	20V
VR0504	4813830A40	33V
VR0505	4805656W09	20V
VR0509	4813830A40	33V
VR0510	4813830A40	33V
VR0521	4813830A15	5.6V
VR0522	4813830A15	5.6V
VR0537	4813830A15	5.6V
VR0541	4813830A27	14V
VR0601	4813832C77	24V
VR0621	4813830A15	5.6V
Y0131	4880113R19	XTAL

* Motorola Depot Servicing only
 Reference designators with an asterisk indicate components which are not fieldreplaceable because they need to be calibrated with specialized factory equipment after installation. Radios in which these parts have been replaced in the field will be off frequency at temperature extremes.

3.0 Controller T5 / Schematic Diagrams

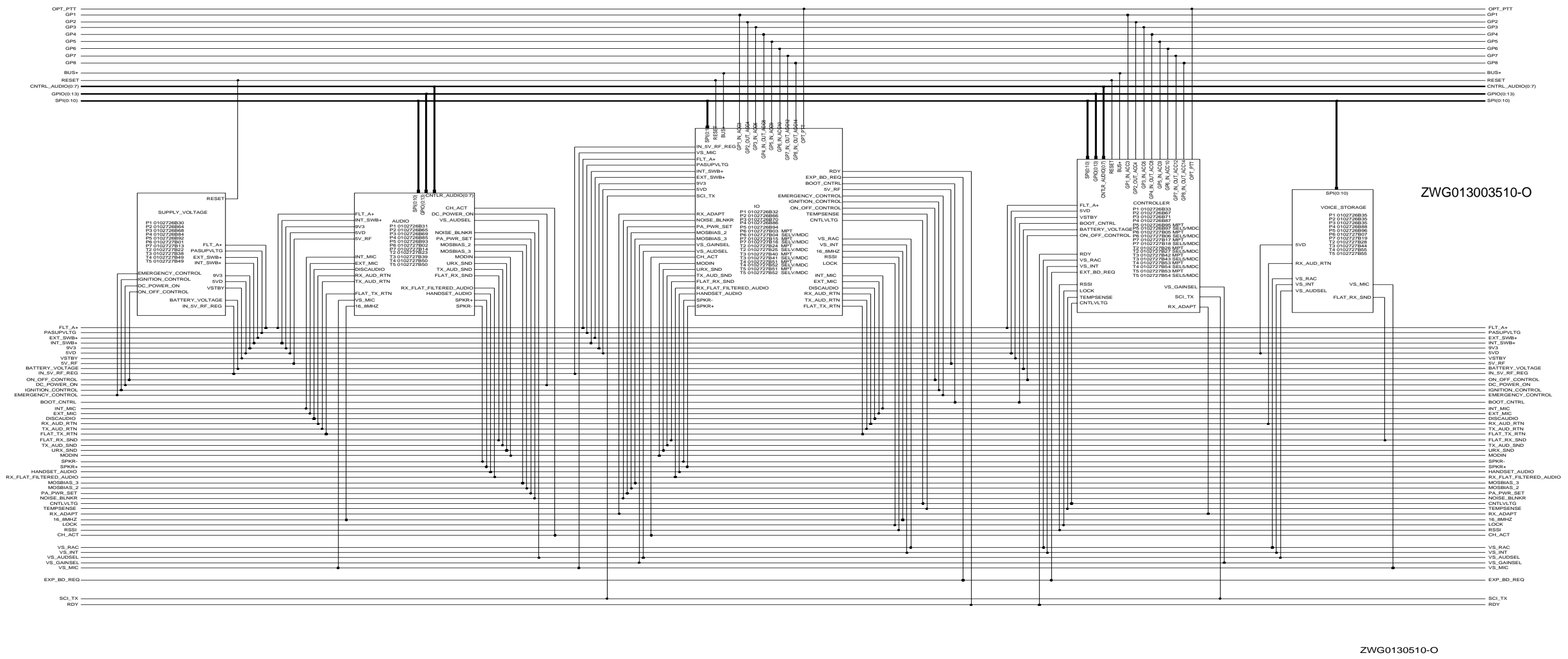

Controller T5 Schematic Diagram - Controller Overall

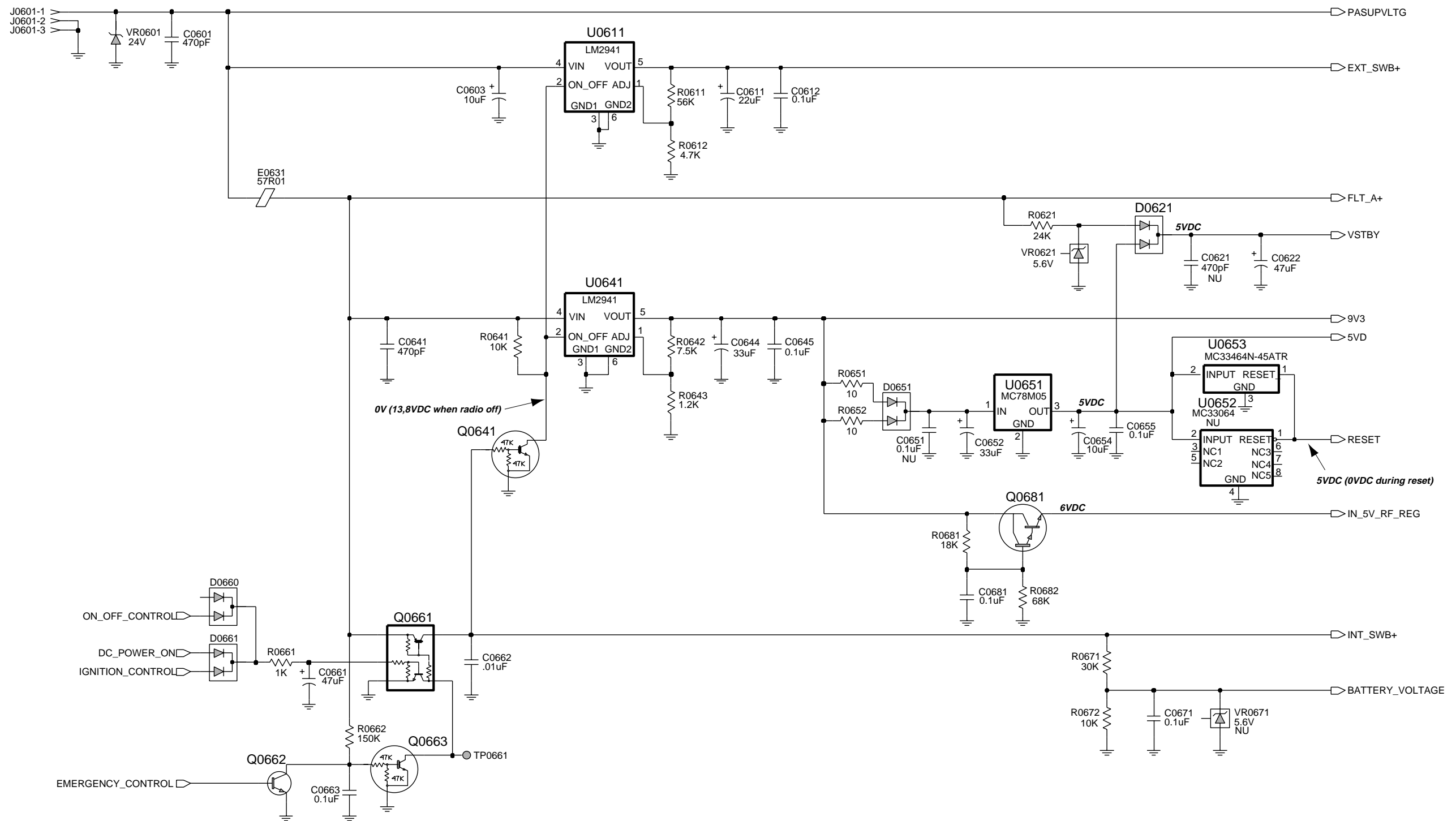

ZWG013030506-O

Controller T5 Schematic Diagram - Supply Voltage

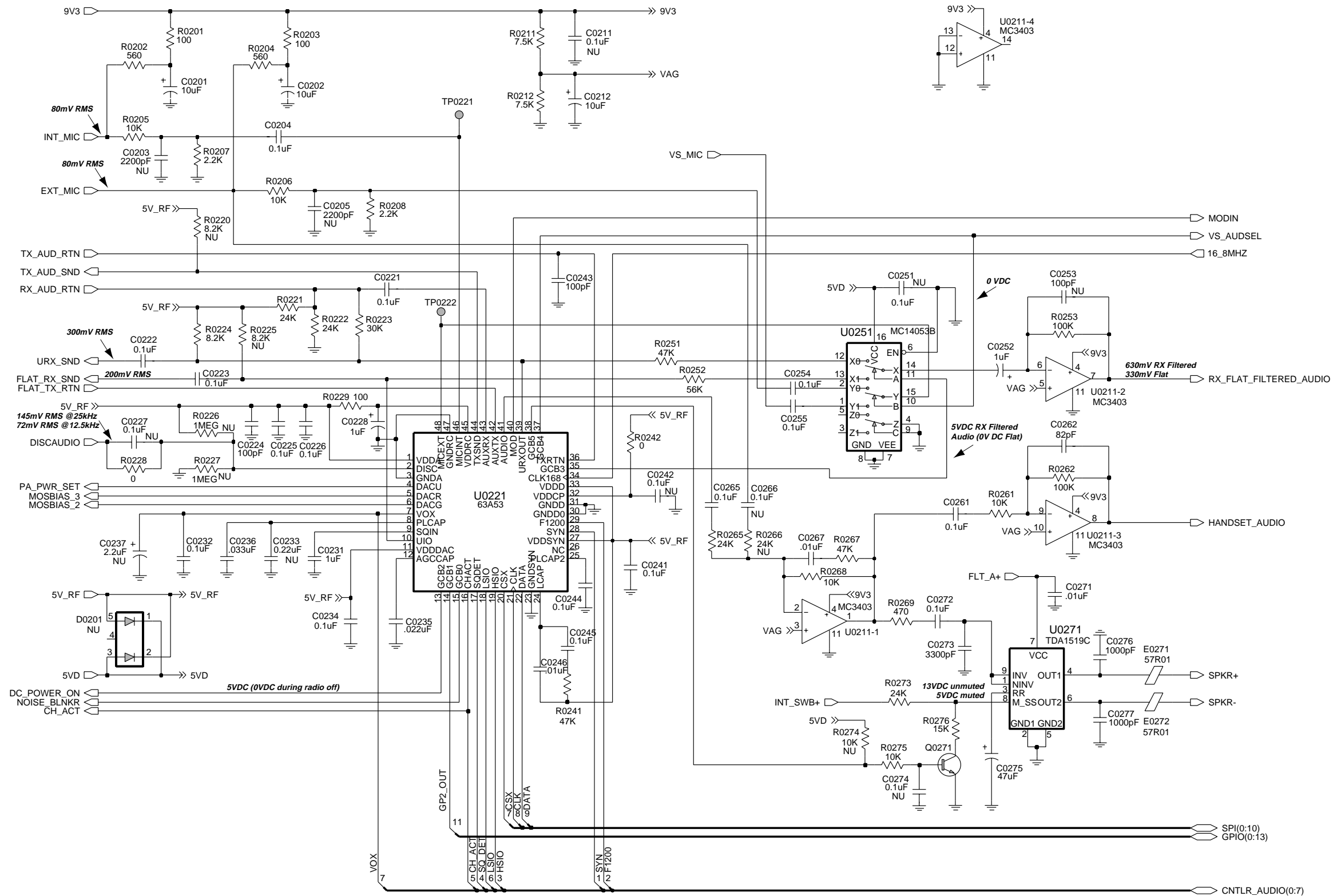

ZWG0130507-O

**Controller T5
Schematic Diagram -
Audio**

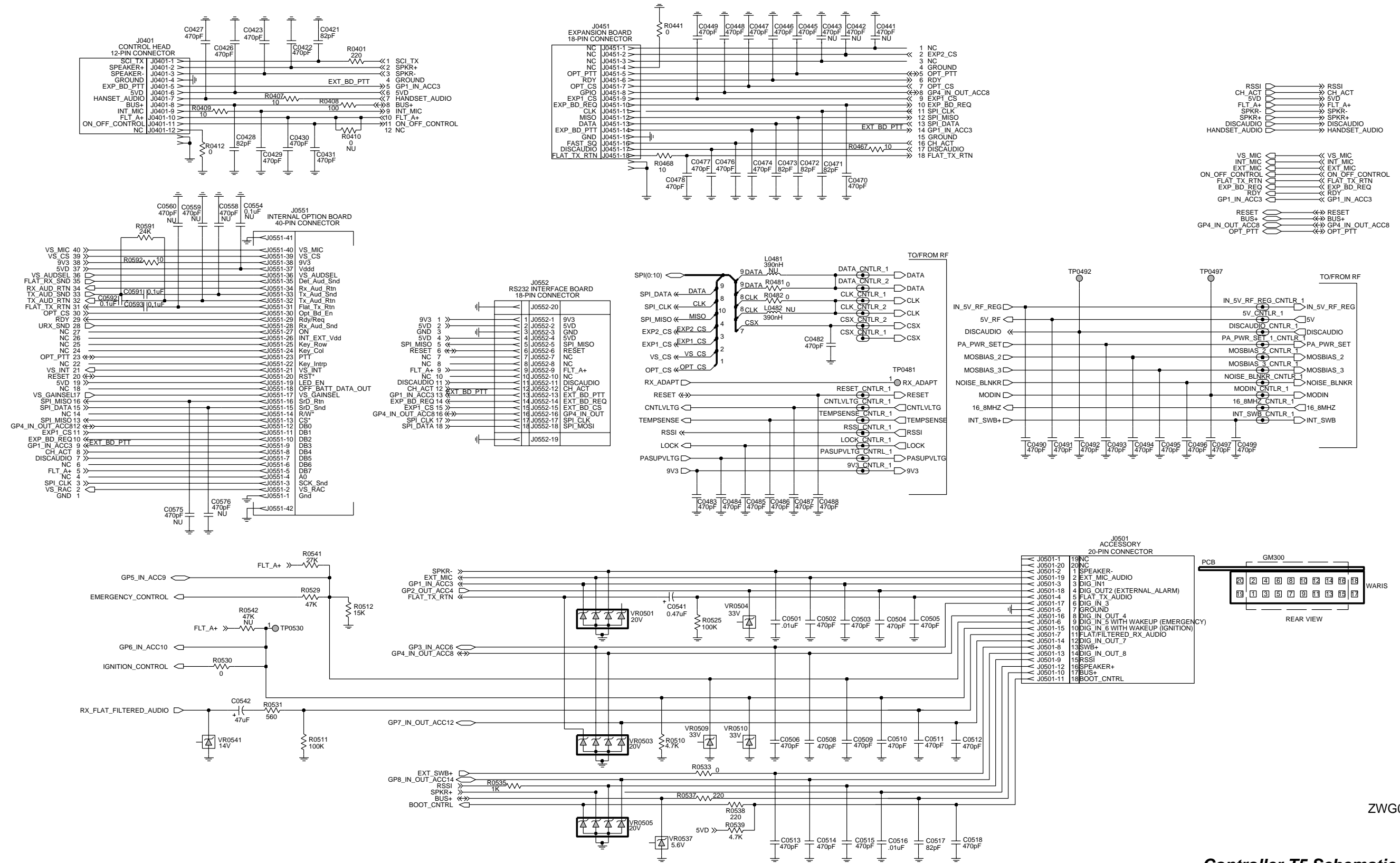

ZWG0130508-O

Controller T5 Schematic Diagram - I/O

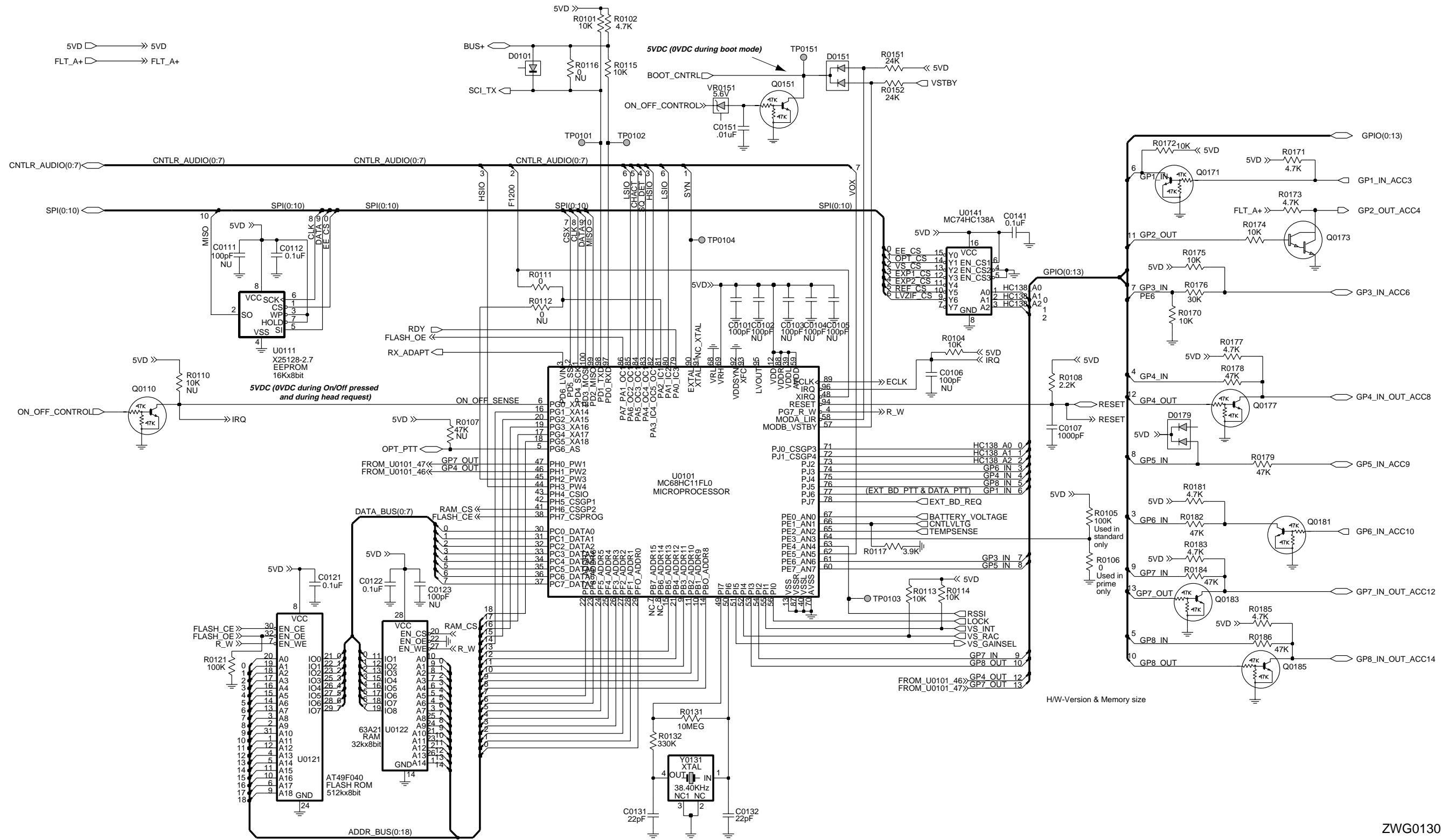

H/W-Version & Memory size

ZWG0130509-A

Controller T5 Schematic Diagram - Microprocessor

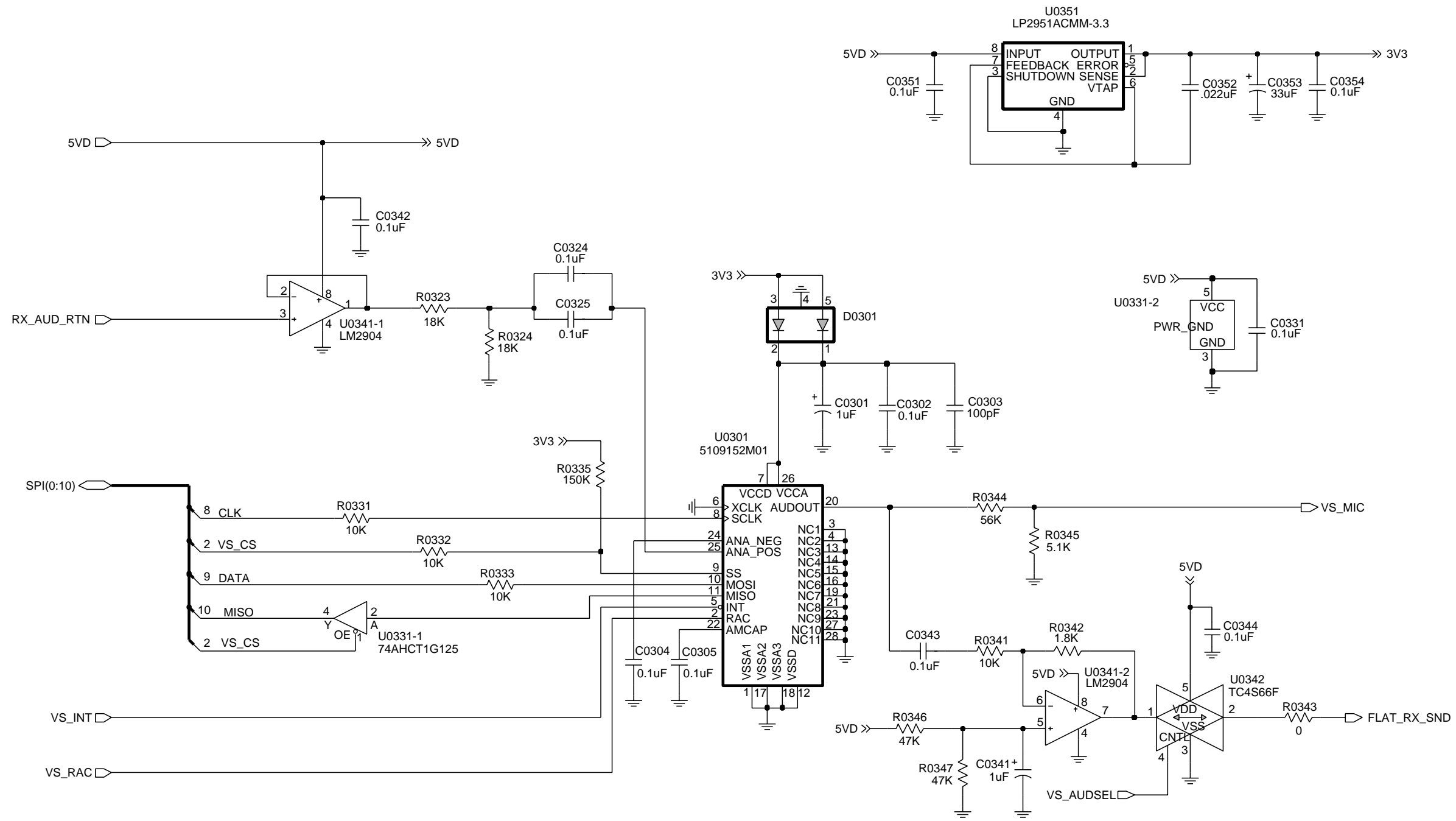

ZWG0130505-O

Controller T5 Schematic Diagram - Voice Storage

3.1 Controller T5 Parts List

Circuit Ref	Motorola Part No	Description
C0101	2113740F51	100pF 5% 50V
C0107	2113741F25	1nF 50V
C0112	2113743E20	100nF 16V
C0121	2113743E20	100nF 16V
C0122	2113743E20	100nF 16V
C0131	2113740F35	22pF 5% 50V
C0132	2113740F35	22pF 5% 50V
C0141	2113743E20	100nF 16V
C0151	2113741F49	10nF 50V
C0201	2311049A57	TANT CP 10uF 10% 16V
C0202	2311049A57	TANT CP 10uF 10% 16V
C0204	2113743E20	100nF 16V
C0212	2311049A57	TANT CP 10uF 10% 16V
C0221	2113743E20	100nF 16V
C0222	2113743E20	100nF 16V
C0223	2113743E20	100nF 16V
C0224	2113740F51	100pF 5% 50V NPO
C0225	2113743E20	100nF 16V
C0226	2113743E20	100nF 16V
C0228	2311049A07	TANT CP 1uF 10% 16V
C0231	2113743B29	1 UF 10% 16V
C0232	2113743E20	100nF 16V
C0234	2113743E20	100nF 16V
C0235	2113743E07	22nF 16V
C0236	2113743E10	.033UF 10%
C0241	2113743E20	100nF 16V
C0243	2113740F51	100pF 5% 50V
C0244	2113743E20	100nF 16V
C0245	2113743E20	100nF 16V
C0246	2113741F49	10nF 50V
C0252	2311049A07	TANT CP 1uF 10%
C0254	2113743E20	100nF 16V
C0255	2113743E20	100nF 16V
C0261	2113743E20	100nF 16V
C0262	2113740F49	82pF 5% 50V
C0265	2113743E20	100nF 16V
C0267	2113741F49	10nF 50V
C0271	2113741F49	10nF 50V
C0272	2113743E20	100nF 16V
C0273	2113741F37	3.3nF 50V
C0275	2311049A99	TANT CP 47uF 20% 10V
C0276	2113741F25	1nF 50V
C0277	2113741F25	1nF 50V
C0301 Used in	2311049A07 GM1280 only	1uF 10% 16V

Circuit Ref	Motorola Part No	Description
C0302 Used in	2113743E20 GM1280 only	100nF 16V
C0303 Used in	2113740F51 GM1280 only	100pF 5% 50V
C0304 Used in	2113743E20 GM1280 only	100nF 16V
C0305 Used in	2113743E20 GM1280 only	100nF 16V
C0324 Used in	2113743E20 GM1280 only	100nF 16V
C0331 Used in	2113743E20 GM1280 only	100nF 16V
C0341 Used in	2311049A07 GM1280 only	TANT CP 1uF 10% 16V
C0342 Used in	2113743E20 GM1280 only	100nF 16V
C0343 Used in	2113743E20 GM1280 only	100nF 16V
C0344 Used in	2113743E20 GM1280 only	100nF 16V
C0351 Used in	2113743E20 GM1280 only	100nF 16V
C0352 Used in	2113743E07 GM1280 only	22nF 16V
C0353 Used in	2311049A97 GM1280 only	TANT CHIP 33 UF 16
C0354 Used in	2113743E20 GM1280 only	100nF 16V
C0421	2113743N48	82.0 PF 5%
C0422	2113741F17	470pF 50V
C0423	2113741F17	470pF 50V
C0426	2113743L09	470 PF 10%
C0427	2113743L09	470 PF 10%
C0428	2113743N48	82.0 PF 5%
C0429	2113743L09	470 PF 10%
C0430	2113741F17	470pF 50V
C0431	2113741F17	470pF 50V
C0445	2113743L09	470 PF 10%
C0446	2113743L09	470 PF 10%
C0447	2113743L09	470 PF 10%
C0448	2113743L09	470 PF 10%
C0449	2113743L09	470 PF 10%
C0470	2113743L09	470 PF 10%
C0471	2113743N48	82.0 PF 5%
C0472	2113743N48	82.0 PF 5%
C0473	2113743N48	82.0 PF 5%
C0474	2113743L09	470 PF 10%
C0476	2113743L09	470 PF 10%
C0477	2113743L09	470 PF 10%

Circuit Ref	Motorola Part No	Description
C0478	2113743L09	470 PF 10%
C0482	2113743L09	470 PF 10%
C0483	2113743L09	470 PF 10%
C0484	2113741F17	470 pF 50V
C0485	2113743L09	470 PF 10%
C0486	2113743L09	470 PF 10%
C0487	2113743L09	470 PF 10%
C0488	2113743L09	470 PF 10%
C0490	2113743L09	470 PF 10%
C0491	2113743L09	470 PF 10%
C0492	2113743L09	470 PF 10%
C0493	2113743L09	470 PF 10%
C0494	2113743L09	470 PF 10%
C0495	2113743L09	470 PF 10%
C0496	2113743L09	470 PF 10%
C0497	2113743L09	470 PF 10%
C0499	2113743L09	470 PF 10%
C0501	2113741F49	10nF 50V
C0502	2113743L09	470 PF 10%
C0503	2113743L09	470 PF 10%
C0504	2113743L09	470 PF 10%
C0505	2113743L09	470 PF 10%
C0506	2113743L09	470 PF 10%
C0508	2113743L09	470 PF 10%
C0509	2113743L09	470 PF 10%
C0510	2113741F17	470 pF 50V
C0511	2113743L09	470 PF 10%
C0512	2113743L09	470 PF 10%
C0513	2113741F17	470 pF 50V
C0514	2113743L09	470 PF 10%
C0515	2113743L09	470 PF 10%
C0516	2113741F49	10nF 50V
C0517	2113743N48	82.0 PF 5%
C0518	2113743L09	470 PF 10%
C0541	2311049A05	TANT CP 470nF 10% 25V
C0542	2311049A99	TANT CP 47uF 20% 10V
C0591	2113743E20	100nF 16V
C0592	2113743E20	100nF 16V
C0593	2113741B69	100nF 50V
C0601	2113741F17	470pF 50V
C0603	2380090M24	LYT 10uF 50V 20%
C0611	2311049C06	TANT CP 22uF 20% 35V
C0612	2113743E20	100nF 16V
C0622	2311049A99	TANT CP 47uF 20% 10V
C0641	2113741F17	470pF 50V
C0644	2311049A97	TANT CHIP 33 UF 16
C0645	2113743E20	100nF 16V

Circuit Ref	Motorola Part No	Description
C0652	2311049A97	TANT CHIP 33 UF 16
C0654	2311049A57	TANT CP 10uF 10% 16V
C0655	2113743E20	100nF 16V
C0661	2311049C05	TANT CP 47uF 10% 16V
C0662	2113741F49	10nF 50V
C0663	2113743E20	100nF 16V
C0671	2113743E20	100nF 16V
C0681	2113743E20	100nF 16V
D0101	4880236E05	CHIP SCHOTTKY
D0151	4813833C02	DUAL SOT MMBD6100
D0179	4813833C02	DUAL SOT MMBD6100
D0301 Used in	4802245J47 GM1280 only	SCHOTTKY BARRIER (RB471E)
D0621	4813833C02	DUAL SOT MMBD6100
D0651	4813833C02	DUAL SOT MMBD6100
D0660	4813833C02	DUAL SOT MMBD6100
D0661	4813833C02	DUAL SOT MMBD6100
E0271	2484657R01	Ferrite Bead
E0272	2484657R01	Ferrite Bead
E0631	2484657R01	Ferrite Bead
J0401	0902636Y02	CONN FLEX 12 PIN
J0451	0902636Y01	CONN FLEX SIDE ENTRY
J0501	0986105B01	CONN SMD 20 PIN
J0551	0905505Y04	CONN ZIF HORIZONTAL
J0552	0905505Y03	CONN ZIF 18PIN
J0601	0986165B01	DC PWR CONN
Q0110	4880048M01	NPN DIG 47k/47k
Q0151	4880048M01	NPN DIG 47k/47k
Q0171	4880048M01	NPN DIG 47k/47k
Q0173	4880052M01	NPN DRLNGTN MXTA
Q0177	4880048M01	NPN DIG 47k/47k
Q0181	4880048M01	NPN DIG 47k/47k
Q0183	4880048M01	NPN DIG 47k/47k
Q0185	4880048M01	NPN DIG 47k/47k
Q0271	4813824A10	NPN 40V .2A
Q0641	4880048M01	NPN DIG 47k/47k
Q0661	4805921T02	DUAL ROHM FMC2 RH
Q0662	4813824A10	NPN 40V .2A B=50-150
Q0663	4880048M01	NPN DIG 47k/47k
Q0681	4880052M01	NPN DRLNGTN MXTA
R0101	0662057A73	10k 1/16W 5%
R0102	0662057A65	4k7 1/16W 5%
R0104	0662057A73	10k 1/16W 5%
R0105	0662057A97	100k 1/16W
Used in	GM140/160	GM340/360/640/660 only
R0106	0662057B47	0 1/16W
Used in	GM380	GM1280 only
R0108	0662057A57	2k2 1/16W 5%

Circuit Ref	Motorola Part No	Description
R0111	0662057B47	0 1/16W
R0113	0662057A73	10k 1/16W 5%
R0114	0662057A73	10k 1/16W 5%
R0115	0662057A73	10k 1/16W 5%
R0117	0662057A63	3k9 1/16W 5%
R0121	0662057A97	100k 1/16W
R0131	0662057B46	10.0 MEG OHMS 5%
R0132	0662057B10	330k 1/16W 5%
R0151	0662057A82	24K 1/16W 5%
R0152	0662057A82	24K 1/16W 5%
R0170	0662057A73	10k 1/16W 5%
R0171	0662057A65	4k7 1/16W 5%
R0172	0662057A73	10k 1/16W 5%
R0173	0662057A65	4k7 1/16W 5%
R0174	0662057A73	10k 1/16W 5%
R0175	0662057A73	10k 1/16W 5%
R0176	0662057A84	30k 1/16W 5%
R0177	0662057A65	4k7 1/16W 5%
R0178	0662057A89	47k 1/16W 5%
R0179	0662057A89	47k 1/16W 5%
R0181	0662057A65	4k7 1/16W 5%
R0182	0662057A89	47k 1/16W 5%
R0183	0662057A65	4k7 1/16W 5%
R0184	0662057A89	47k 1/16W 5%
R0185	0662057A65	4k7 1/16W 5%
R0186	0662057A89	47k 1/16W 5%
R0201	0662057A25	100 1/16W 5%
R0202	0662057A43	560 1/16W 5%
R0203	0662057A25	100 1/16W 5%
R0204	0662057A43	560 1/16W 5%
R0205	0662057A73	10k 1/16W 5%
R0206	0662057A73	10k 1/16W 5%
R0207	0662057A57	2k2 1/16W 5%
R0208	0662057A57	2k2 1/16W 5%
R0211	0660076E70	FILM 7500
R0212	0660076E70	FILM 7500
R0221	0662057A82	24K 1/16W 5%
R0222	0662057A82	24K 1/16W 5%
R0223	0662057A84	30k 1/16W 5%
R0224	0662057A71	8k2 1/16W 5%
R0228	0662057B47	0 1/16W
R0229	0662057A25	100 1/16W 5%
R0241	0662057A89	47k 1/16W 5%
R0242	0662057B47	0 1/16W
R0251	0662057A89	47k 1/16W 5%
R0252	0662057A91	56K 1/16W 5%
R0253	0662057A97	100k 1/16W

Circuit Ref	Motorola Part No	Description
R0261	0662057A73	10k 1/16W 5%
R0262	0662057A97	100k 1/16W
R0265	0662057A82	24K 1/16W 5%
R0267	0662057A89	47k 1/16W 5%
R0268	0662057A73	10k 1/16W 5%
R0269	0662057A41	470 1/16W 5%
R0273	0662057A82	24K 1/16W 5%
R0275	0662057A73	10k 1/16W 5%
R0276	0662057A77	15k 1/16W 5%
R0323	0662057A79	18k 1/16W 5%
Used in	GM1280 only	
R0324	0662057A79	18k 1/16W 5%
Used in	GM1280 only	
R0331	0662057A73	10k 1/16W 5%
Used in	GM1280 only	
R0332	0662057A73	10k 1/16W 5%
Used in	GM1280 only	
R0333	0662057A73	10k 1/16W 5%
Used in	GM1280 only	
R0335	0662057B02	150k 1/16W
Used in	GM1280 only	
R0341	0662057A73	10k 1/16W 5%
Used in	GM1280 only	
R0342	0662057A55	1k8 1/16W 5%
Used in	GM1280 only	
R0343	0662057B47	0 1/16W
Used in	GM1280 only	
R0344	0662057A91	56K 1/16W 5%
Used in	GM1280 only	
R0345	0662057A66	5k1 1/16W 5%
Used in	GM1280 only	
R0346	0662057A89	47k 1/16W 5%
Used in	GM1280 only	
R0347	0662057A89	47k 1/16W 5%
Used in	GM1280 only	
R0401	0662057A33	220 1/16W 5%
R0407	0662057M26	10 5%
R0408	0662057A25	100 1/16W 5%
R0409	0662057M26	10 5%
R0412	0662057B47	0 1/16W
R0441	0662057B47	0 1/16W
R0467	0662057M26	10 5%
R0468	0662057M26	10 5%
R0481	0662057B47	0 1/16W
R0482	0662057B47	0 1/16W
R0510	0662057A65	4k7 1/16W 5%
R0511	0662057A97	100k 1/16W
R0512	0662057A77	15k 1/16W 5%
R0525	0662057A97	100k 1/16W

Circuit Ref	Motorola Part No	Description
R0529	0662057A89	47k 1/16W 5%
R0530	0662057B47	0 1/16W
R0531	0662057A43	560 1/16W 5%
R0533	0662057B47	0 1/16W
R0535	0662057A49	1k 1/16W
R0537	0662057A33	220 1/16W 5%
R0538	0662057A33	220 1/16W 5%
R0539	0662057A65	4k7 1/16W 5%
R0541	0662057A83	27k 1/16W 5%
R0591	0662057A82	24K 1/16W 5%
R0592	0662057A01	10 1/16W 5%
R0611	0662057A91	56K 1/16W 5%
R0612	0662057A65	4k7 1/16W 5%
R0621	0662057A82	24K 1/16W 5%
R0641	0662057A73	10k 1/16W 5%
R0642	0660076E70	FILM 7500 1 1
R0643	0660076E51	FILM 1200 1 1
R0651	0662057A01	10 1/16W 5%
R0652	0662057A01	10 1/16W 5%
R0661	0662057A49	1k 1/16W 5%
R0662	0662057B02	150k 1/16W
R0671	0662057A84	30k 1/16W 5%
R0672	0662057A73	10k 1/16W 5%
R0681	0662057A79	18k 1/16W 5%
R0682	0662057A93	68k 1/16W 5%
U0101	5102226J56	MICRO PROCESSOR MC68HC1
* U0111	5102463J64	EEPROM X25128-2.7 SO8
* U0121	5186137B01	IC 512KX8 FLASH ROM (AT49BV020)
U0122	5185963A21	IC 32K x 8 SRAM
U0141	5113805A30	IC 10F8 DCDR/REMUX 74HC138
U0211	5183222M49	IC QUAD OPAMP __ 3403
U0221	5185963A53	ASFICCOMP 0.5MM TQFP
U0251	5113806A20	MUX/DEMUX,TRIPLE 2-
U0271	5109699X01	AUDIO PA TDA1519C
U0301	5109152M01	EEPROM ANALOG
Used in	GM1280 only	ISD33120EI
U0331	5186204B01	BUFFER/DRIVER
Used in	GM1280 only	74AHCT1G125
U0341	5180932W01	LINEAR IC OP AMP
Used in	GM1280 only	
U0342	5105750U28	SNGL ANALOG SWITCH
Used in	GM1280 only	
U0351	5102463J40	REGULATOR, 3.3V
Used in	GM1280 only	
U0611	5183308X01	ADJ VLTG REG LM2941 TO263

Circuit Ref	Motorola Part No	Description
U0641	5183308X01	ADJ VLTG REG LM2941 TO263
U0651	5113816A07	REG 5V POS 500MA MC78M05
U0653	5186205B01	MC33464N-45ATR SOT23-5-RB
VR0151	4813830A15	5.6V 5% 225mW
VR0501	4805656W09	ZENER QUAD MMQA20VT1
VR0503	4805656W09	ZENER QUAD MMQA20VT1
VR0504	4813830A40	SOC23 AUTO SDN
VR0505	4805656W09	ZENER QUAD MMQA20VT1
VR0509	4813830A40	SOC23 AUTO SDN
VR0510	4813830A40	SOC23 AUTO SDN
VR0537	4813830A15	5.6V 5% 225mW
VR0541	4813830A27	14V 5% 225MW
VR0601	4813832C77	TRANS SUP. 24V HIGPWR
VR0621	4813830A15	DIODE 5.6V 5% 225mW
Y0131	4880113R19	CRYSTAL 38.4KHZ

* Motorola Depot Servicing only
 Reference designators with an asterisk indicate components which are not fieldreplaceable because they need to be calibrated with specialized factory equipment after installation. Radios in which these parts have been replaced in the field will be off frequency at temperature extremes.

4.0 Controller T6/7 / Schematic Diagrams

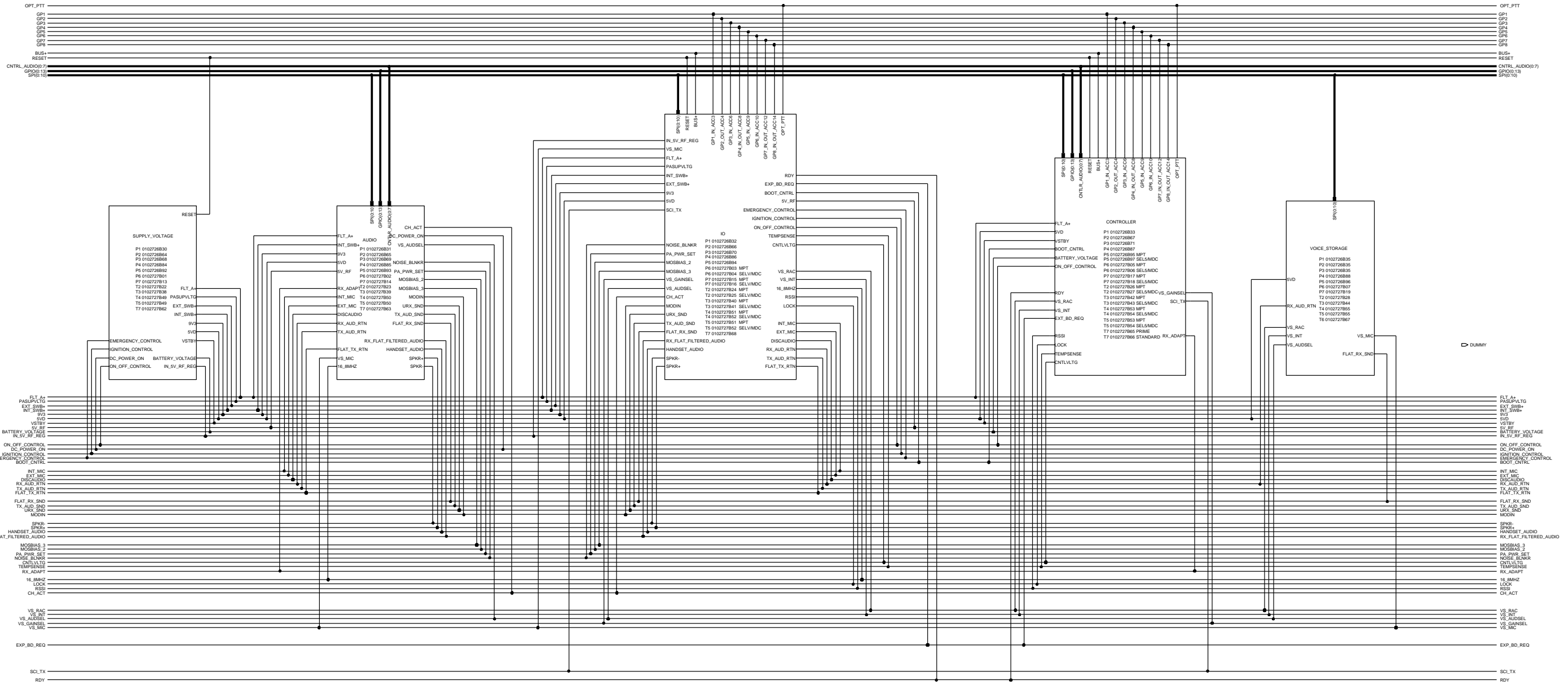

ZWG0130525-O

Controller T6/7 Schematic Diagram - Overall

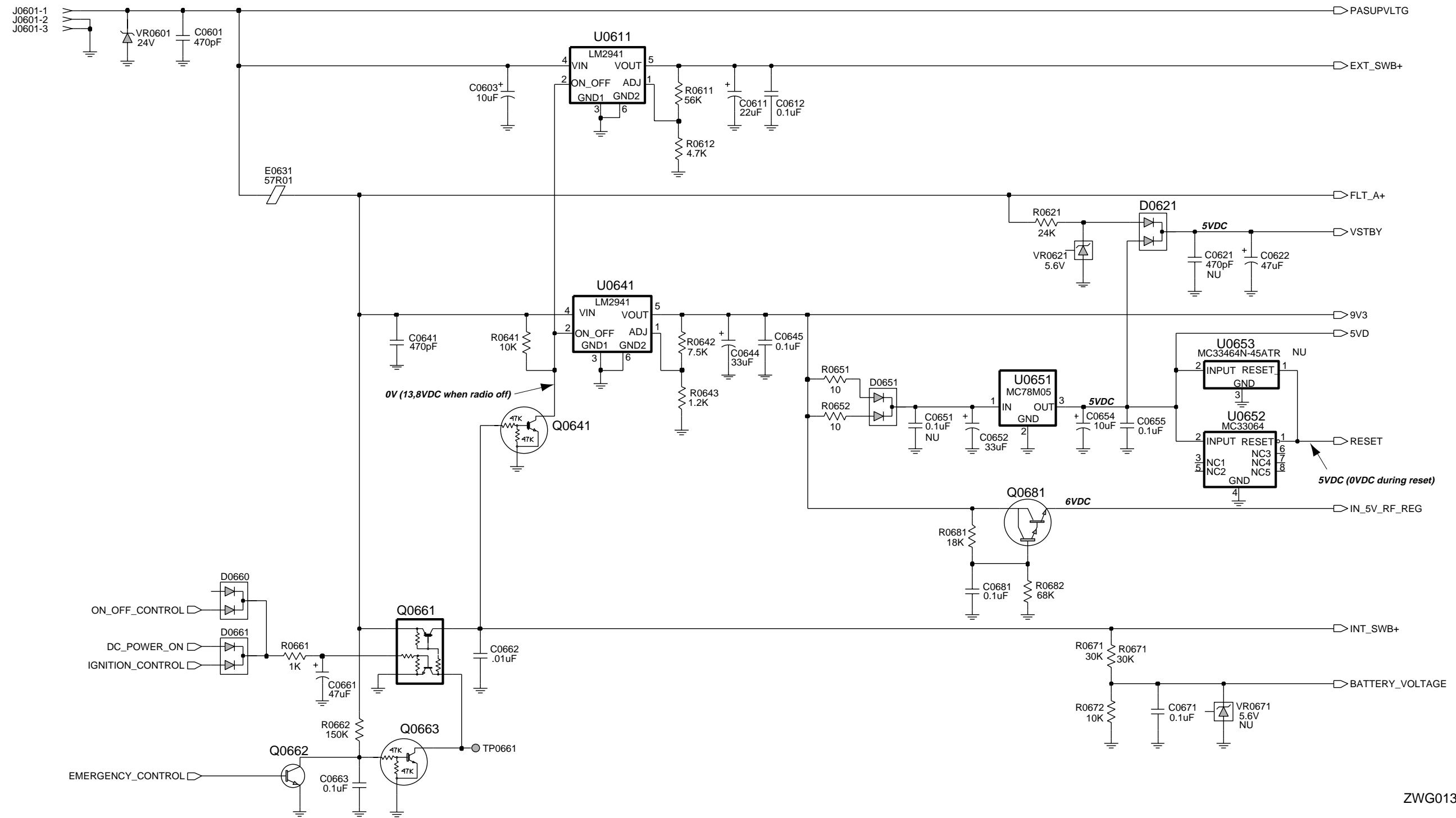

ZWG0130529-A

Controller T6/7 Schematic Diagram - Supply Voltage

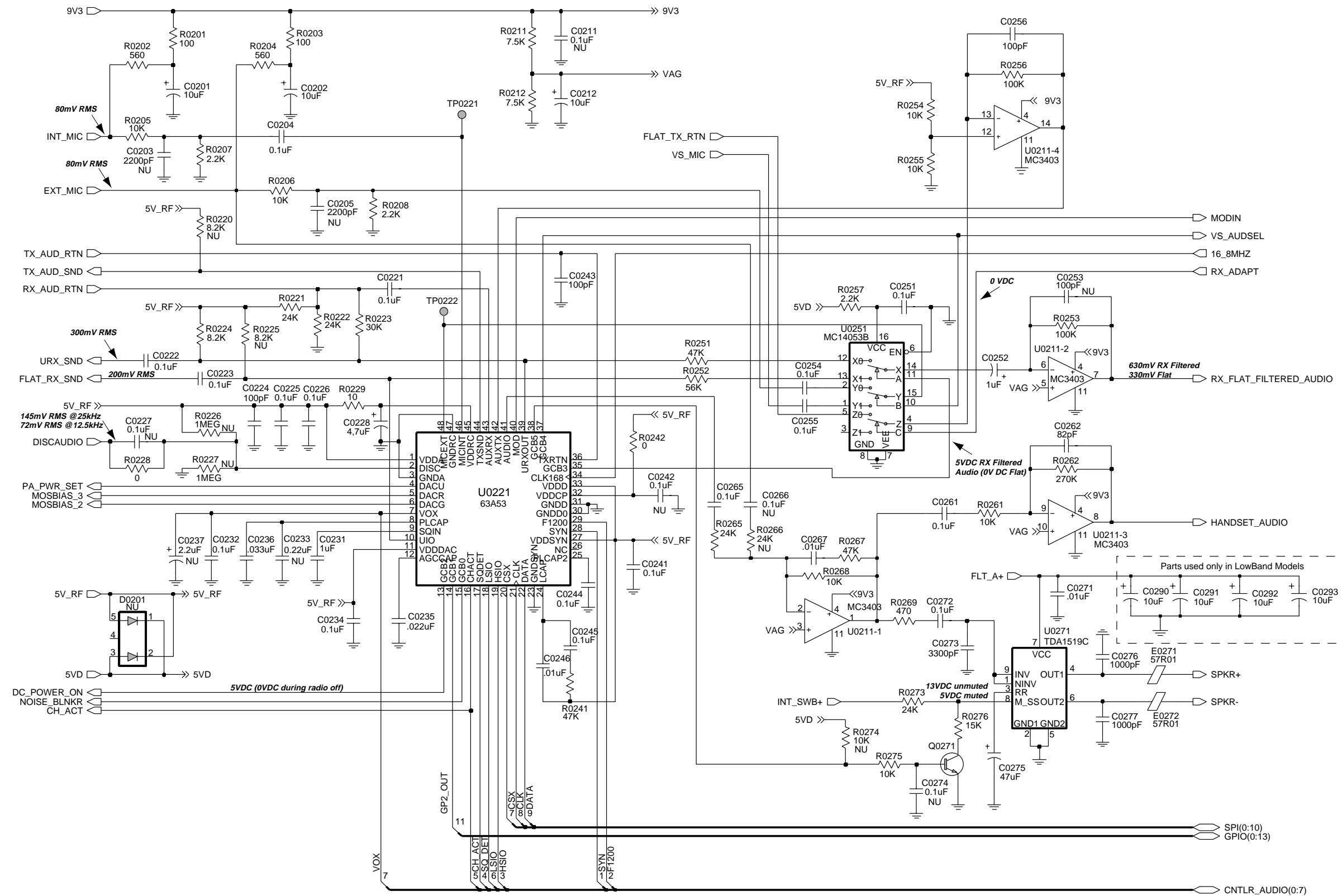

ZWG0130528-B

Controller T6/T7 Schematic Diagram - Audio

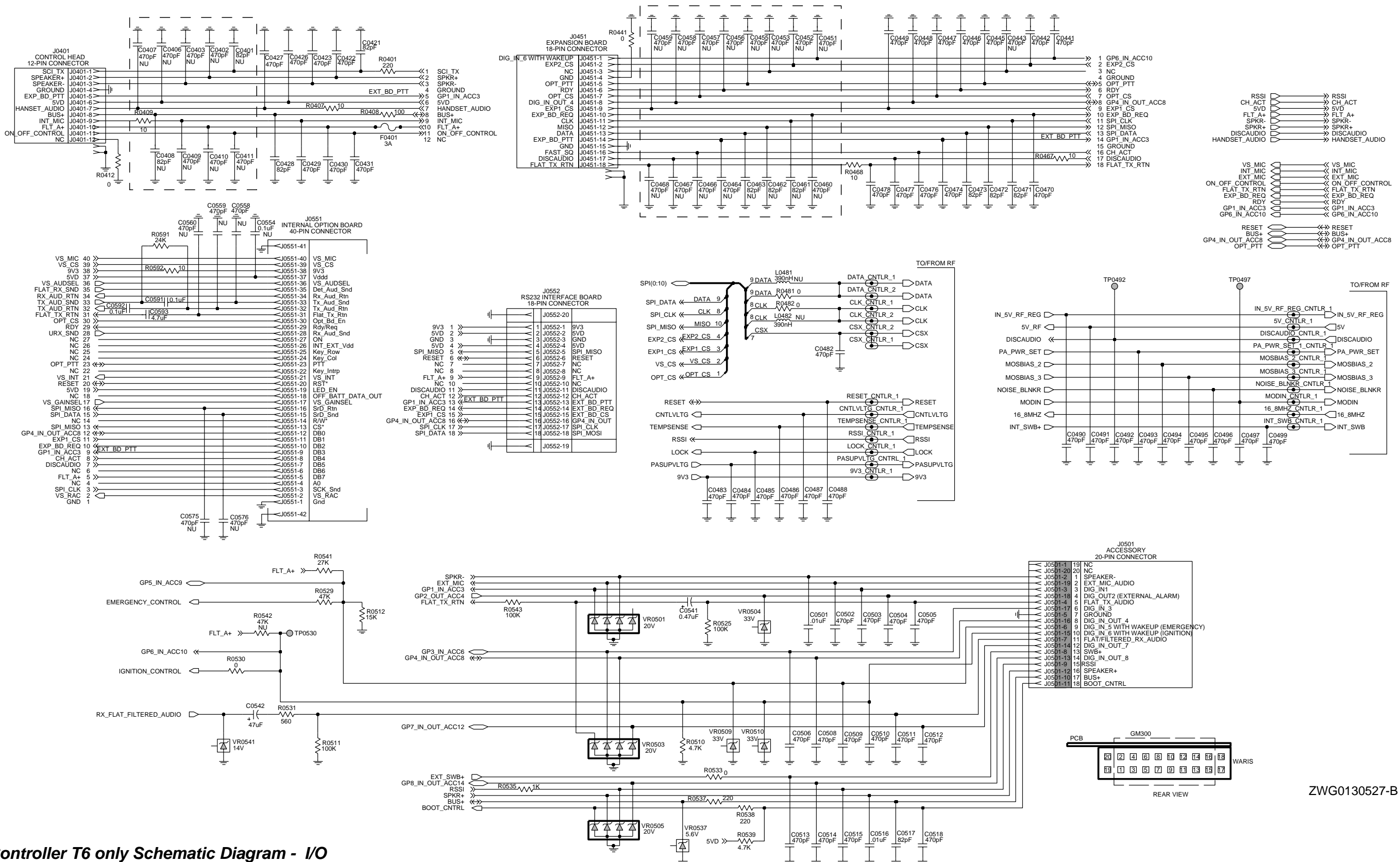

Controller T6 only Schematic Diagram - I/O

ZWG0130527-B

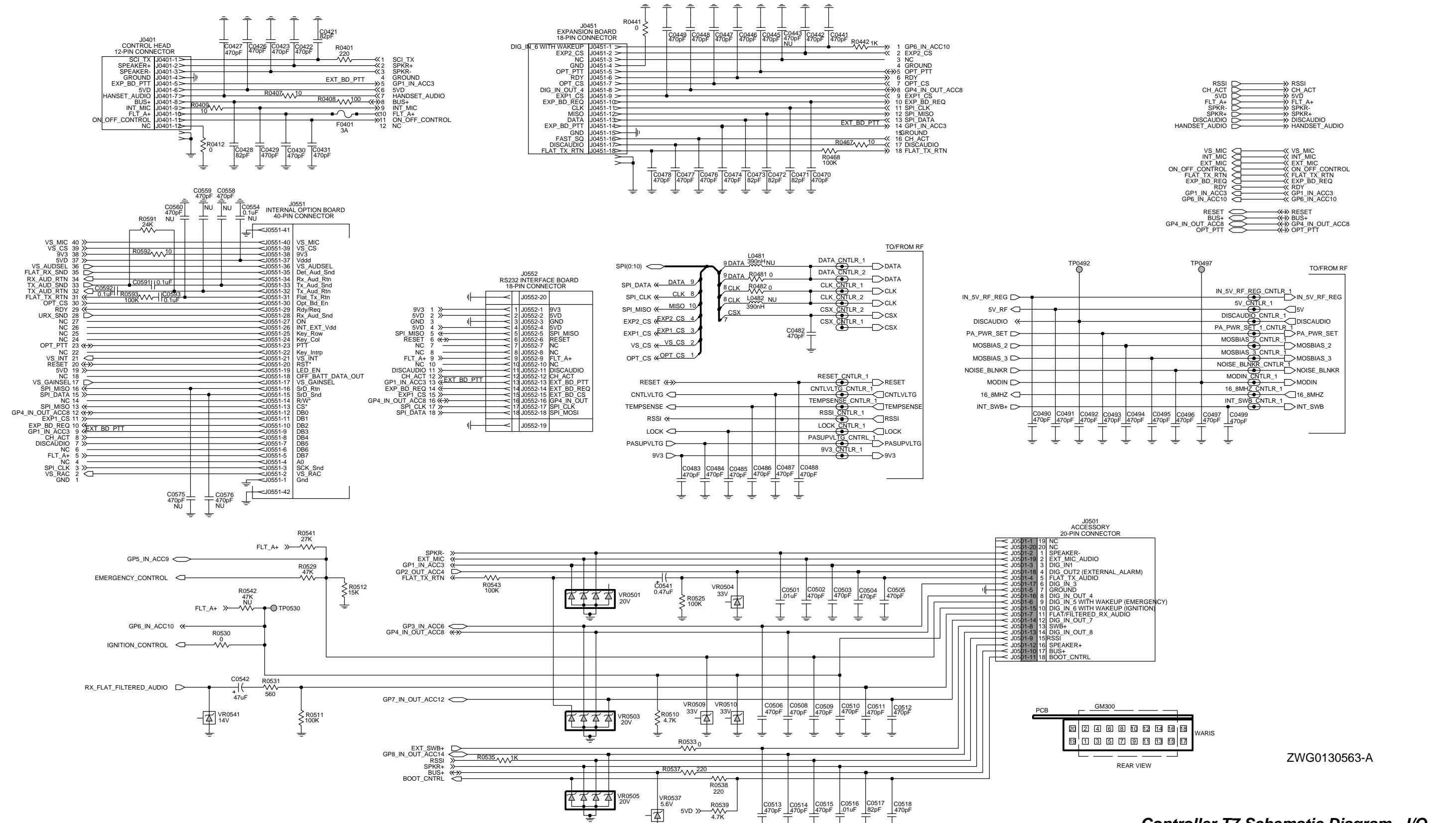

Controller T7 Schematic Diagram - I/O

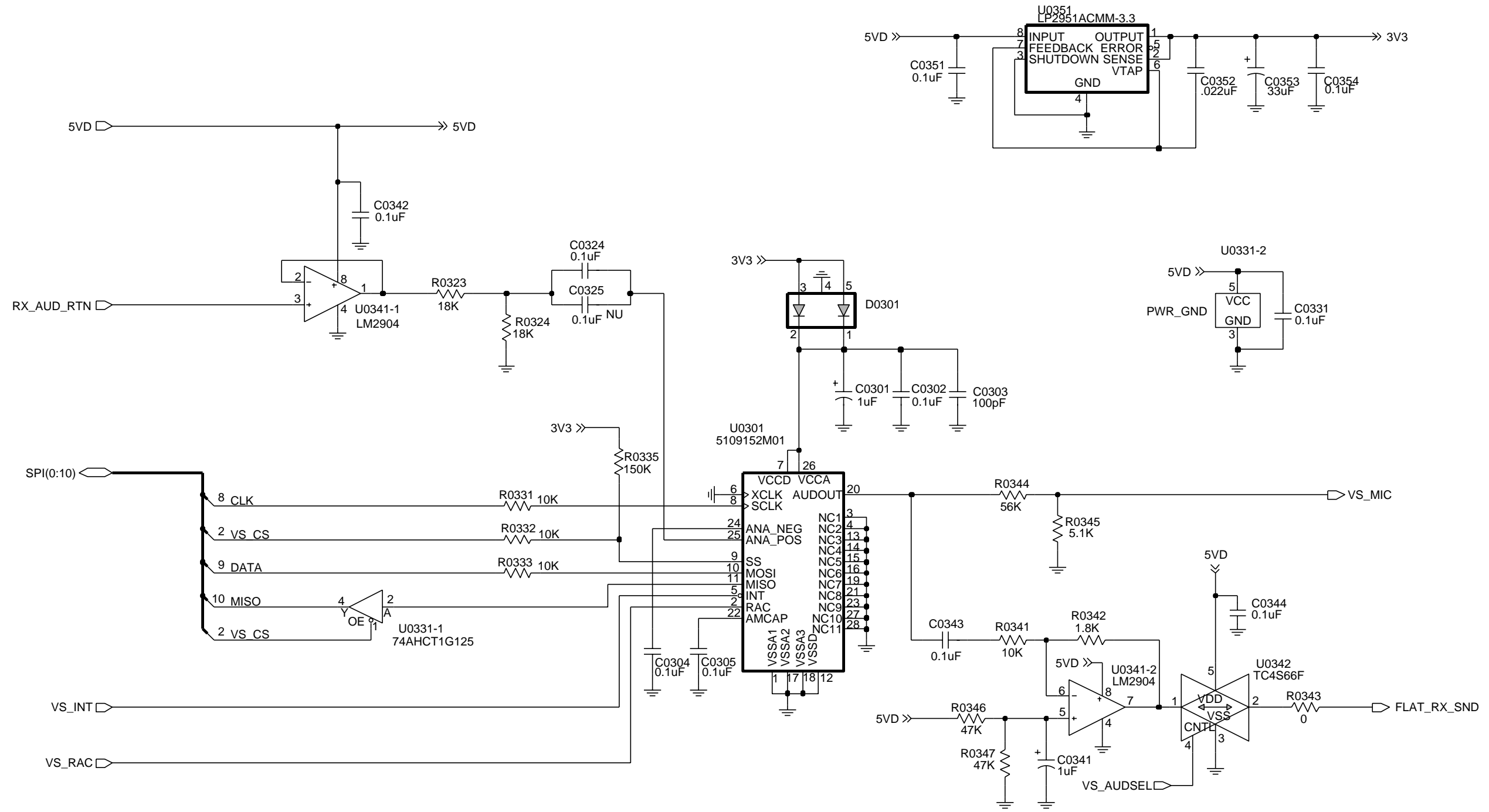

ZWG0130530-O

Controller T6/7 Schematic Diagram - Voice Storage

4.1 Controller T6/7 Parts List

Circuit Ref	Motorola Part No	Description
C0101	2113740F51	100pF 5% 50V
C0107	2113741F25	1nF 50V
C0112	2113743E20	100nF 16V
C0121	2113743E20	100nF 16V
C0122	2113743E20	100nF 16V
C0131	2113740F35	22pF 5% 50V
C0132	2113740F35	22pF 5% 50V
C0141	2113743E20	100nF 16V
C0151	2113741F49	10nF 50V
C0201	2311049A57	10uF 10% 16V
C0202	2311049A57	10uF 10% 16V
C0204	2113743E20	100nF 16V
C0212	2311049A57	10uF 10% 16V
C0221	2113743E20	100nF 16V
C0222	2113743E20	100nF 16V
C0223	2113743E20	100nF 16V
C0224	2113740F51	100pF 5% 50V
C0225	2113743E20	100nF 16V
C0226	2113743E20	100nF 16V
C0228	2311049A56	4.7uF 10% 16V
C0231	2113743B29	1 uF 10% 16V
C0232	2113743E20	100nF 16V
C0234	2113743E20	100nF 16V
C0235	2113743E07	22nF 16V
C0236	2113743E10	.033UF 10%
C0241	2113743E20	100nF 16V
C0243	2113740F51	100pF 5% 50V
C0244	2113743E20	100nF 16V
C0245	2113743E20	100nF 16V
C0246	2113741F49	10nF 50V
C0251	2113743E20	100nF 16V
Used in		CNTRL T7 only
C0252	2311049A07	1uF 10% 16V
C0254	2113743E20	100nF 16V
C0255	2113743E20	100nF 16V
C0256	2113740F51	100pF 5% 50V
C0261	2113743E20	100nF 16V
C0262	2113740F49	82pF 5% 50V NPO
C0265	2113743E20	100nF 16V
C0267	2113741F49	10nF 50V
C0271	2113741F49	10nF 50V
C0272	2113743E20	100nF 16V
C0273	2113741F37	3.3nF 50V
C0275	2311049A99	47uF 20% 10V
C0276	2113741F25	1nF 50V X7R
C0277	2113741F25	1nF 50V X7R
C0290	2311049C01	10uF (only LowBand)
C0291	2311049C01	10uF (only LowBand)
C0292	2311049C01	10uF (only LowBand)
C0293	2311049C01	10uF (only LowBand)

Circuit Ref	Motorola Part No	Description
C0301	2311049A07	TANT CP 1uF 10% 16V
Used in		GM1280 only
C0302	2113743E20	100nF 16V
Used in		GM1280 only
C0303	2113740F51	100pF 5% 50V
Used in		GM1280 only
C0304	2113743E20	100nF 16V
Used in		GM1280 only
C0305	2113743E20	100nF 16V
Used in		GM1280 only
C0324	2113743E20	100nF 16V
Used in		GM1280 only
C0331	2113743E20	100nF 16V
Used in		GM1280 only
C0341	2311049A07	TANT CP 1uF 10% 16V
Used in		GM1280 only
C0342	2113743E20	100nF 16V
Used in		GM1280 only
C0343	2113743E20	100nF 16V
Used in		GM1280 only
C0344	2113743E20	100nF 16V
Used in		GM1280 only
C0351	2113743E20	100nF 16V
Used in		GM1280 only
C0352	2113743E07	22nF 16V
Used in		GM1280 only
C0353	2311049A97	TANT CHIP 33 UF
Used in		GM1280 only
C0354	2113743E20	100nF 16V
Used in		GM1280 only
C0421	2113743N48	82.0 PF 5%
C0422	2113741F17	470pF 50V
C0423	2113741F17	470pF 50V
C0426	2113743L09	470 PF 10%
C0427	2113743L09	470 PF 10%
C0428	2113743N48	82.0 PF 5%
C0429	2113743L09	470 PF 10%
C0430	2113741F17	470pF 50V
C0431	2113741F17	470pF 50V
C0441	2113743L09	470 PF 10%
C0442	2113743L09	470 PF 10%
C0445	2113743L09	470 PF 10%
C0446	2113743L09	470 PF 10%
C0447	2113743L09	470 PF 10%
C0448	2113743L09	470 PF 10%
C0449	2113743L09	470 PF 10%
C0470	2113743L09	470 PF 10%
C0471	2113743N48	82.0 PF 5%
C0472	2113743N48	82.0 PF 5%
C0473	2113743N48	82.0 PF 5%
C0474	2113743L09	470 PF 10%
C0476	2113743L09	470 PF 10%
C0477	2113743L09	470 PF 10%

Circuit Ref	Motorola Part No	Description
C0478	2113743L09	470 PF 10%
C0482	2113743L09	470 PF 10%
C0483	2113743L09	470 PF 10%
C0484	2113741F17	470pF 50V
C0485	2113743L09	470 PF 10%
C0486	2113743L09	470 PF 10%
C0487	2113743L09	470 PF 10%
C0488	2113743L09	470 PF 10%
C0490	2113743L09	470 PF 10%
C0491	2113743L09	470 PF 10%
C0492	2113743L09	470 PF 10%
C0493	2113743L09	470 PF 10%
C0494	2113743L09	470 PF 10%
C0495	2113743L09	470 PF 10%
C0496	2113743L09	470 PF 10%
C0497	2113743L09	470 PF 10%
C0499	2113743L09	470 PF 10%
C0501	2113741F49	10nF 50V
C0502	2113743L09	470pF 10% (CNTRL T6)
C0502	2113741F17	470pF 50V (CNTRL T7)
C0503	2113743L09	470pF 10% (CNTRL T6)
C0503	2113741F17	470pF 50V (CNTRL T7)
C0504	2113741F17	470pF 50V
C0505	2113743L09	470pF 10% (CNTRL T6)
C0505	2113741F17	470pF 50V (CNTRL T7)
C0506	2113743L09	470pF 10% (CNTRL T6)
C0506	2113741F17	470pF 50V (CNTRL T7)
C0508	2113743L09	470pF 10% (CNTRL T6)
C0508	2113741F17	470pF 50V (CNTRL T7)
C0509	2113743L09	470pF 10% (CNTRL T6)
C0509	2113741F17	470pF 50V (CNTRL T7)
C0510	2113741F17	470pF 50V
C0511	2113743L09	470pF 10% (CNTRL T6)
C0511	2113741F17	470pF 50V (CNTRL T7)
C0512	2113743L09	470pF 10% (CNTRL T6)
C0512	2113741F17	470pF 50V (CNTRL T7)
C0513	2113741F17	470pF 50V
C0514	2113743L09	470pF 10% (CNTRL T6)
C0514	2113741F17	470pF 50V (CNTRL T7)
C0515	2113743L09	470pF 10% (CNTRL T6)
C0515	2113741F17	470pF 50V (CNTRL T7)
C0516	2113741F49	10nF 50V
C0517	2113743N48	82.0 PF 5%
C0518	2113743L09	470pF 10% (CNTRL T6)
C0518	2113741F17	470pF 50V (CNTRL T7)
C0541	2311049A05	470nF 10% 25V
C0542	2311049A99	47uF 20% 10V
C0591	2113743E20	100nF 16V
C0592	2113743E20	100nF 16V
C0593	2113741B69	100nF 50V
C0601	2113741F17	470pF 50V

Circuit Ref	Motorola Part No	Description
C0603	2380090M24	LYT 10uF 50V 20%
C0611	2311049C06	CP 22uF 20% 35V
C0612	2113743E20	100nF 16V
C0622	2311049A99	CP 47uF 20%
C0641	2113741F17	470pF 50V
C0644	2311049A97	CHIP 33 UF
C0645	2113743E20	100nF 16VD
C0652	2311049A97	CHIP 33 UF 16
C0654	2311049A57	CP 10uF 10% 16V
C0655	2113743E20	100nF 16V
C0661	2311049C05	CP 47uF 10% 16V
C0662	2113741F49	10nF 50V
C0663	2113743E20	100nF 16V
C0671	2113743E20	100nF 16V
C0681	2113743E20	100nF 16V
D0101	4880236E05	CHIP SCHOTTKY
D0151	4813833C02	DUAL SOT MMBD6100
D0179	4813833C02	DUAL SOT MMBD6100
D0301	4802245J47	SCHOTTKY BARRIER
Used in		GM1280 only (RB471E)
D0621	4813833C02	DUAL SOT MMBD6100
D0651	4813833C02	DUAL SOT MMBD6100
D0660	4813833C02	DUAL SOT MMBD6100
D0661	4813833C02	DUAL SOT MMBD6100
E0271	2484657R01	Ferrite Bead
E0272	2484657R01	Ferrite Bead
E0631	2484657R01	Ferrite Bead
F0401	6580542Z01	3A 24V
J0401	0902636Y02	CONN FLEX 12 PIN
J0451	0902636Y01	CONN FLEX SIDE ENTRY
J0501	0986105B01	CONN SMD 20 PIN
J0551	0905505Y04	CONN ZIF HORIZONTAL
J0552	0905505Y03	CONN ZIF 18PIN
J0601	0986165B01	DC PWR CONN
Q0110	4880048M01	NPN DIG 47k/47k
Q0151	4880048M01	NPN DIG 47k/47k
Q0171	4880048M01	NPN DIG 47k/47k
Q0173	4880052M01	NPN DRLNGTN MXTA
Q0177	4880048M01	NPN DIG 47k/47k
Q0181	4880048M01	NPN DIG 47k/47k
Q0183	4880048M01	NPN DIG 47k/47k
Q0185	4880048M01	NPN DIG 47k/47k
Q0271	4813824A10	NPN 40V .2A
Q0641	4880048M01	NPN DIG 47k/47k
Q0661	4805921T02	DUAL ROHM FMC2 RH
Q0662	4813824A10	NPN 40V .2A B=50-150
Q0663	4880048M01	NPN DIG 47k/47k
Q0681	4880052M01	NPN DRLNGTN MXTA
R0101	0662057A73	10k 1/16W 5%
R0102	0662057A65	4k7 1/16W 5%
R0104	0662057A73	10k 1/16W 5%

Circuit Ref	Motorola Part No	Description
R0105	0662057A97	100k 1/16W
Used in	GM140/160	GM340/360/640/660 only
R0106	0662057B47	0 1/16W
Used in		GM380/GM1280 only
R0108	0662057A57	2k2 1/16W 5%
R0111	0662057B47	0 1/16W 0306
R0113	0662057A73	10k 1/16W 5%
R0114	0662057A73	10k 1/16W 5%
R0115	0662057A73	10k 1/16W 5%
R0117	0662057A63	3k9 1/16W 5%
R0121	0662057A97	100k 1/16W
R0131	0662057B46	10.0 MEG OHMS 5%
R0132	0662057B10	330k 1/16W 5%
R0151	0662057A82	24K 1/16W 5%
R0152	0662057A82	24K 1/16W 5%
R0170	0662057A73	10k 1/16W 5%
R0171	0662057A65	4k7 1/16W 5%
R0172	0662057A73	10k 1/16W 5%
R0173	0662057A65	4k7 1/16W 5%
R0174	0662057A73	10k 1/16W 5%
R0175	0662057A73	10k 1/16W 5%
R0176	0662057A84	30k 1/16W 5%
R0177	0662057A65	4k7 1/16W 5%
R0178	0662057A89	47k 1/16W 5%
R0179	0662057A89	47k 1/16W 5%
R0181	0662057A65	4k7 1/16W 5%
R0182	0662057A89	47k 1/16W 5%
R0183	0662057A65	4k7 1/16W 5%
R0184	0662057A89	47k 1/16W 5%
R0185	0662057A65	4k7 1/16W 5%
R0186	0662057A89	47k 1/16W 5%
R0201	0662057A25	100 1/16W 5%
R0202	0662057A43	560 1/16W 5%
R0203	0662057A25	100 1/16W 5%
R0204	0662057A43	560 1/16W 5%
R0205	0662057A73	10k 1/16W 5%
R0206	0662057A73	10k 1/16W 5%
R0207	0662057A57	2k2 1/16W 5%
R0208	0662057A57	2k2 1/16W 5%
R0211	0660076E70	FILM 7500
R0212	0660076E70	FILM 7500
R0221	0662057A82	24K 1/16W 5%
R0222	0662057A82	24K 1/16W 5%
R0223	0662057A84	30k 1/16W 5%
R0224	0662057A71	8k2 1/16W 5%
R0228	0662057B47	0 1/16W
R0229	0662057A01	10 1/16W 5%
R0241	0662057A89	47k 1/16W 5%
R0242	0662057B47	0 1/16W
R0251	0662057A89	47k 1/16W 5%
R0252	0662057A91	56K 1/16W 5%

Circuit Ref	Motorola Part No	Description
R0253	0662057A97	100k 1/16W
R0254	0662057A73	10k 1/16W 5% (CNTRL T7 only)
R0255	0662057A73	10k 1/16W 5% (CNTRL T7 only)
R0256	0662057A97	100k 1/16W (CNTRL T7 only)
R0257	0662057A57	2k2 1/16W 5% (CNTRL T7 only)
R0261	0662057A73	10k 1/16W 5%
R0262	0662057A97	100k 1/16W
R0265	0662057A82	24K 1/16W 5%
R0267	0662057A89	47k 1/16W 5%
R0268	0662057A73	10k 1/16W 5%
R0269	0662057A41	470 1/16W 5%
R0273	0662057A82	24K 1/16W 5%
R0275	0662057A73	10k 1/16W 5%
R0276	0662057A77	15k 1/16W 5%
R0323	0662057A79	18k 1/16W 5%
Used in	GM1280 only	
R0324	0662057A79	18k 1/16W 5%
Used in	GM1280 only	
R0331	0662057A73	10k 1/16W 5%
Used in	GM1280 only	
R0332	0662057A73	10k 1/16W 5%
Used in	GM1280 only	
R0333	0662057A73	10k 1/16W 5%
Used in	GM1280 only	
R0335	0662057B02	150k 1/16W
Used in	GM1280 only	
R0341	0662057A73	10k 1/16W
Used in	GM1280 only	
R0342	0662057A55	1k8 1/16W
Used in	GM1280 only	
R0343	0662057B47	0 1/16W
Used in	GM1280 only	
R0344	0662057A91	56K 1/16W
Used in	GM1280 only	
R0345	0662057A66	5k1 1/16W
Used in	GM1280 only	
R0346	0662057A89	47k 1/16W
Used in	GM1280 only	
R0347	0662057A89	47k 1/16W
Used in	GM1280 only	
R0401	0662057A33	220 1/16W
R0407	0662057M26	10 5% 20X40
R0408	0662057A25	100 1/16W 5%
R0409	0662057M26	10 5% 20X40
R0412	0662057B47	0 1/16W
R0441	0662057B47	0 1/16W
R0442	0662057A49	1k 1/16W 5% CNTRL T7 only
Used in		
R0467	0662057M26	10 5% 20X40

Circuit Ref	Motorola Part No	Description
R0468	0662057M26	10 5% 20X40 (CNTRL T6)
R0468	0662057A97	100k 1/16W (CNTRL T7)
R0481	0662057B47	0 1/16W
R0482	0662057B47	0 1/16W
R0510	0662057A65	4k7 1/16W 5%
R0511	0662057A97	100k 1/16W
R0512	0662057A77	15k 1/16W 5%
R0525	0662057A97	100k 1/16W
R0529	0662057A89	47k 1/16W 5%
R0530	0662057B47	0 1/16W
R0531	0662057A43	560 1/16W 5%
R0533	0662057B47	0 1/16W
R0535	0662057A49	1k 1/16W 5%
R0537	0662057A33	220 1/16W 5%
R0538	0662057A33	220 1/16W 5%
R0539	0662057A65	4k7 1/16W 5%
R0541	0662057A83	27k 1/16W 5%
R0543	0662057A97	100k 1/16W (CNTRL T7 only)
R0591	0662057A82	24K 1/16W 5%
R0592	0662057A01	10 1/16W 5%
R0593	0662057A97	100k 1/16W (CNTRL T7 only)
R0611	0662057A91	56k 1/16W
R0612	0662057A65	4k7 1/16W
R0621	0662057A82	24K 1/16W
R0641	0662057A73	10k 1/16W
R0642	0660076E70	FILM 7500
R0643	0660076E51	FILM 1200
R0651	0662057A01	10 1/16W 5%
R0652	0662057A01	10 1/16W 5%
R0661	0662057A49	1k 1/16W 5%
R0662	0662057B02	150k 1/16W
R0671	0662057A84	30k 1/16W 5%
R0672	0662057A73	10k 1/16W 5%
R0681	0662057A79	18k 1/16W 5%
R0682	0662057A93	68k 1/16W 5%
U0101	5102226J56	MICRO PROCESSOR MC68HC1 1FLO
* U0111	5102463J64	EEPROM X25128-2.7 SO8
* U0121	5186137B01	512KX8 FLASH ROM (AT49BV020)
U0122	5185963A21	32K x 8 SRAM
U0141	5113805A30	10F8 DCDR/REMUX 74HC138
U0211	5183222M49	QUAD OPAMP __3403
U0221	5185130C53	ASFICOMP 0.5MM TQFP
U0251	5113806A20	MUX/DEMUX,TRIPLE 2-
U0271	5109699X01	AUDIO PA TDA1519C
U0301	5109152M01	EEPROM ANALOG
Used in	GM1280 only	ISD33120E1

Circuit Ref	Motorola Part No	Description
U0331	5186204B01	BUFFER/DRIVER 74AHCT1G125
Used in	GM1280 only	
U0341	5180932W01	LINEAR IC OP AMP
Used in	GM1280 only	
U0342	5105750U28	SNGL ANALOG SWITCH SMD
Used in	GM1280 only	
U0351	5102463J40	REGULATOR, 3.3V, LP2951CM-3.3
Used in	GM1280 only	
U0611	5183308X01	ADJ VLTG REG LM2941 TO263
U0641	5183308X01	ADJ VLTG REG LM2941 TO263
U0651	5113816A07	REG 5V POS 500MA MC78M05
U0652	5113815A02	MC33064
VR0151	4813830A15	5.6V 5% 225mW
VR0501	4805656W09	ZENER QUAD MMQA20VT1
VR0503	4805656W09	ZENER QUAD MMQA20VT1
VR0504	4813830A40	SOC23 AUTO SDN
VR0505	4805656W09	ZENER QUAD MMQA20VT1
VR0509	4813830A40	SOC23 AUTO SDN
VR0510	4813830A40	SOC23 AUTO SDN
VR0537	4813830A15	5.6V 5% 225mW
VR0541	4813830A27	14V 5% 225MW
VR0601	4813832C77	TRANS SUP. 24V HIGH POWER
VR0621	4813830A15	5.6V 5% 225mW
Y0131	4880113R19	CRYSTAL 38.4KHz

* Motorola Depot Servicing only

Reference designators with an asterisk indicate components which are not fieldreplaceable because they need to be calibrated with specialized factory equipment after installation. Radios in which these parts have been replaced in the field will be off frequency at temperature extremes.

5.0 Controller T9 / Schematic Diagrams

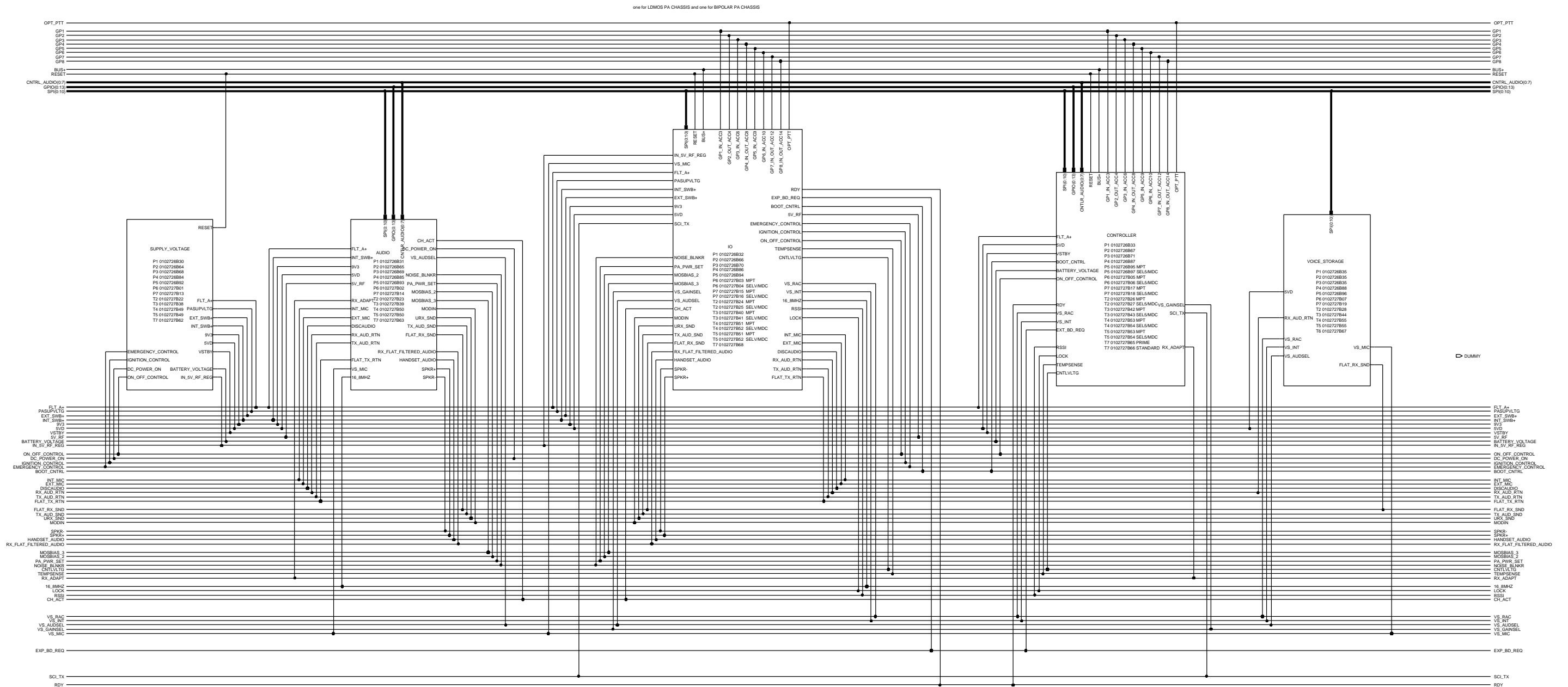

ZWG0130525-O

Controller T9 Schematic Diagram - Overall

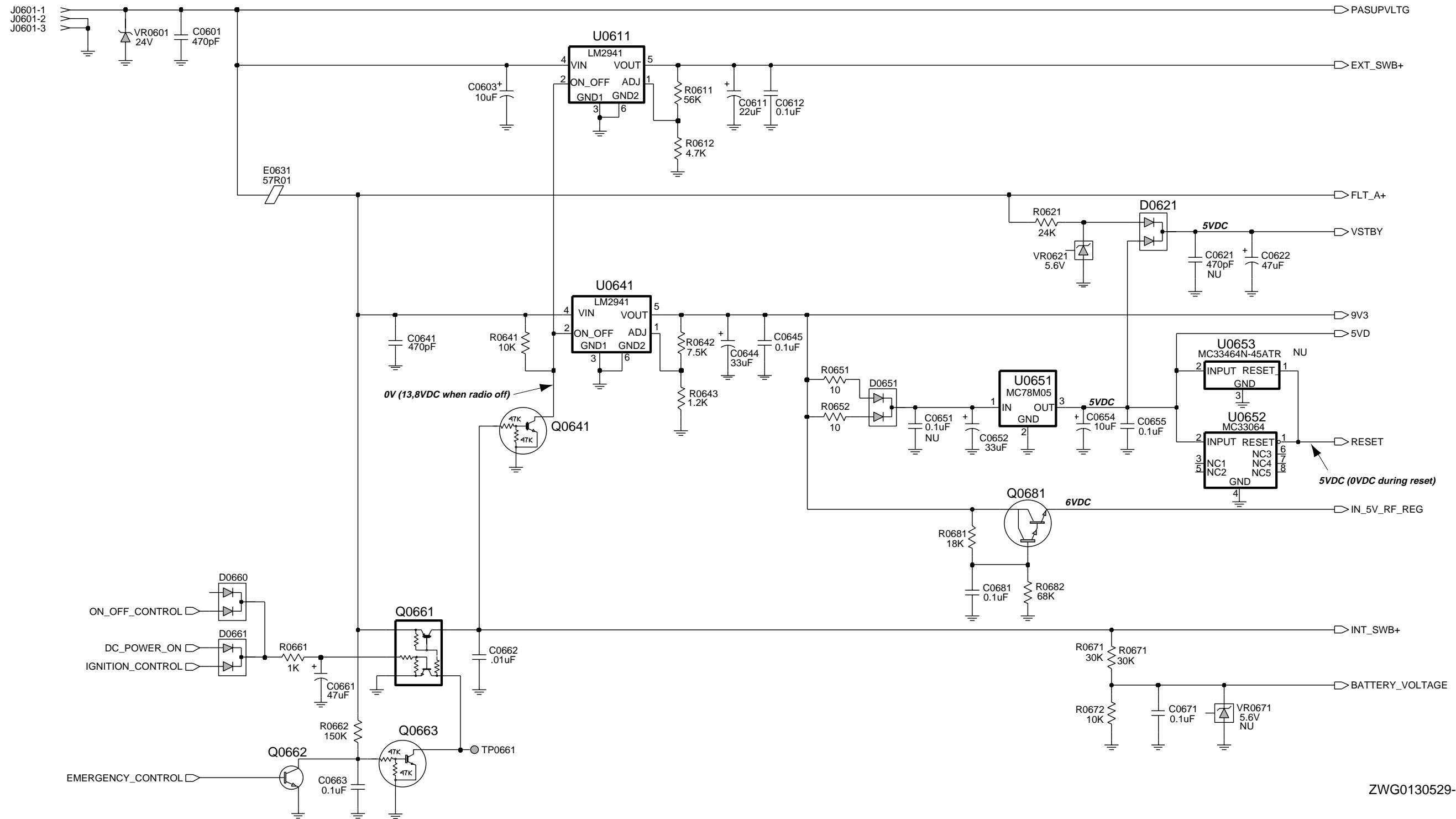

ZWG0130529-A

Controller T9 Schematic Diagram - Supply Voltage

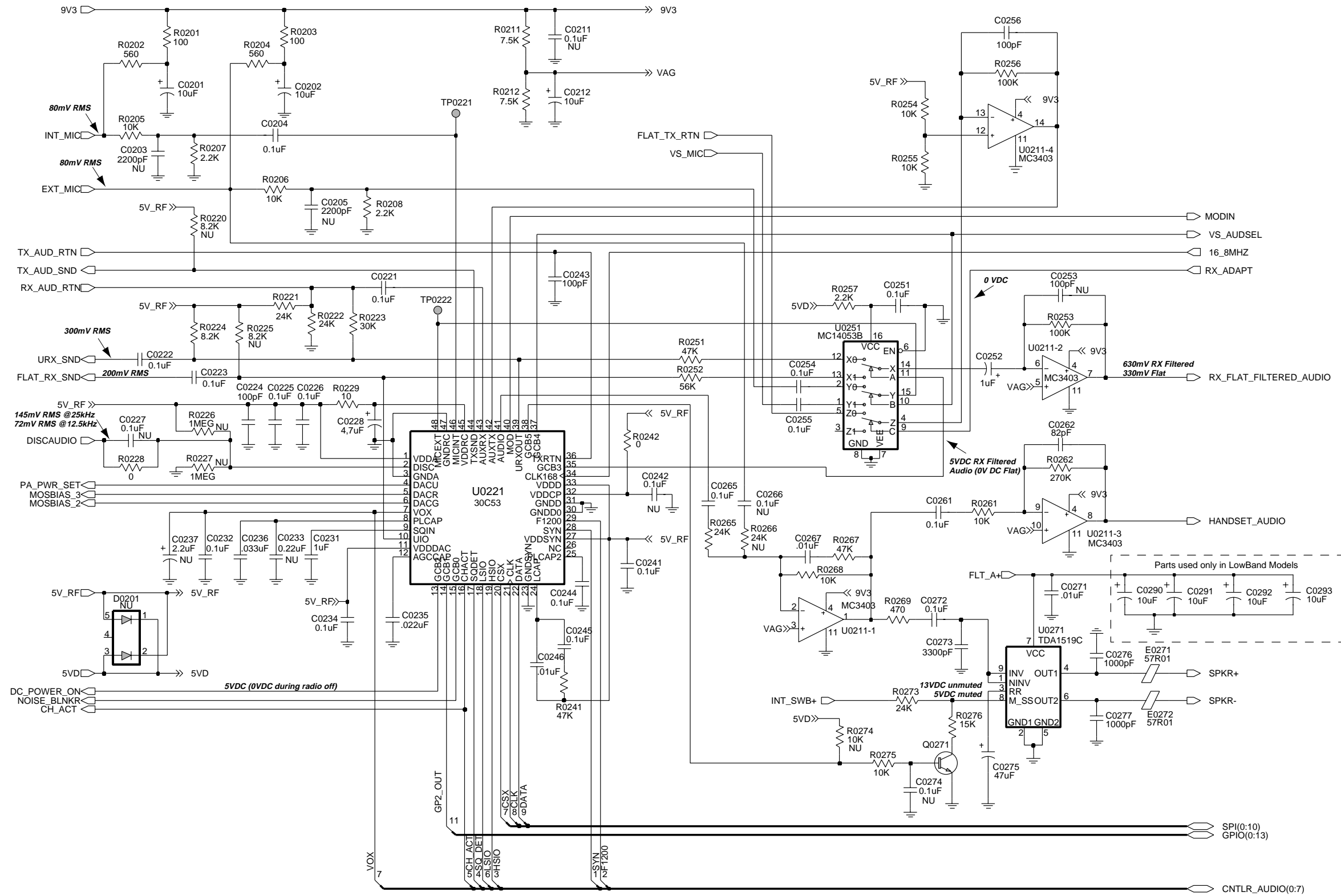

ZWG0130528-B

Controller T9 Schematic Diagram - Audio PA

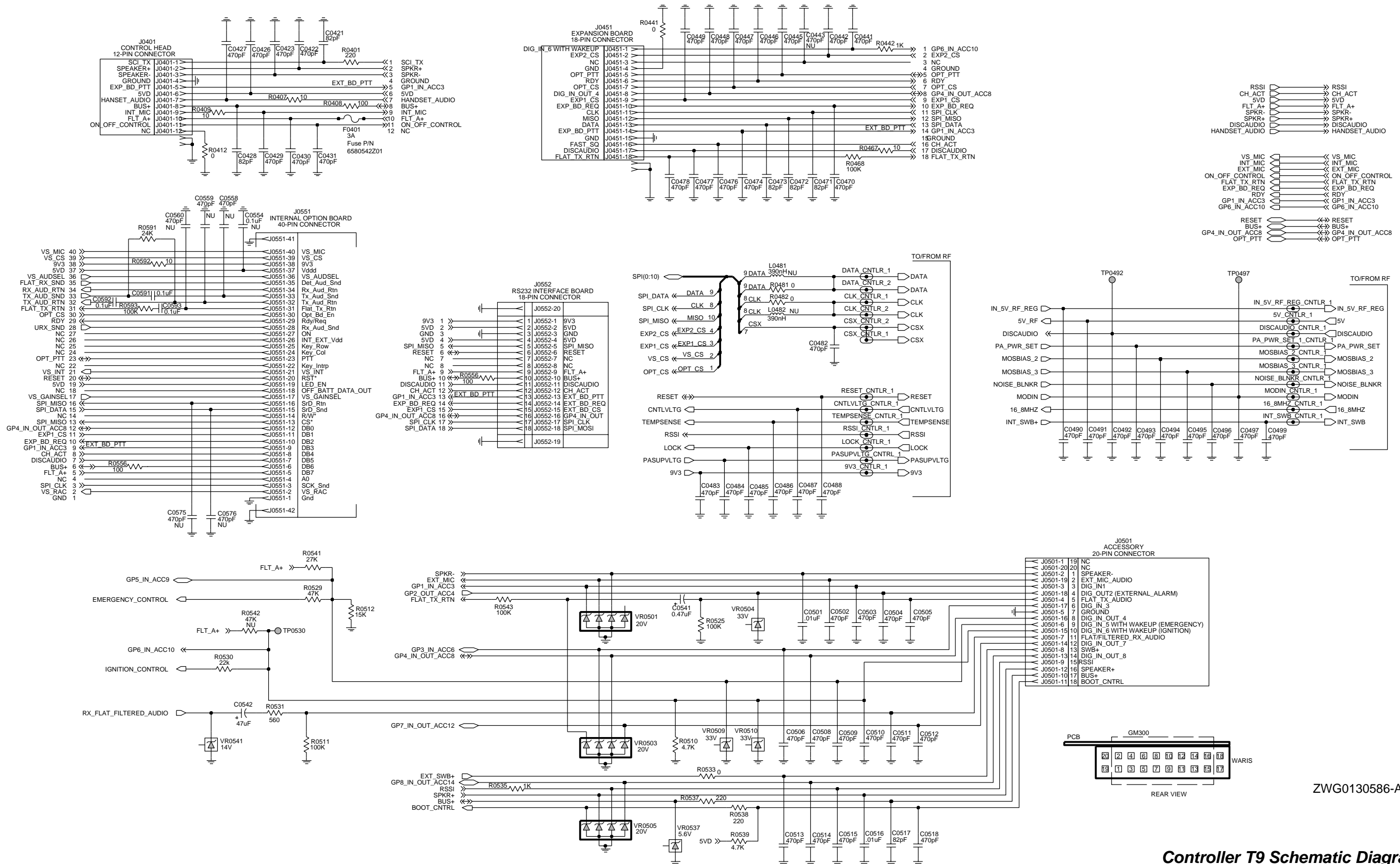

Controller T9 Schematic Diagram - I/O

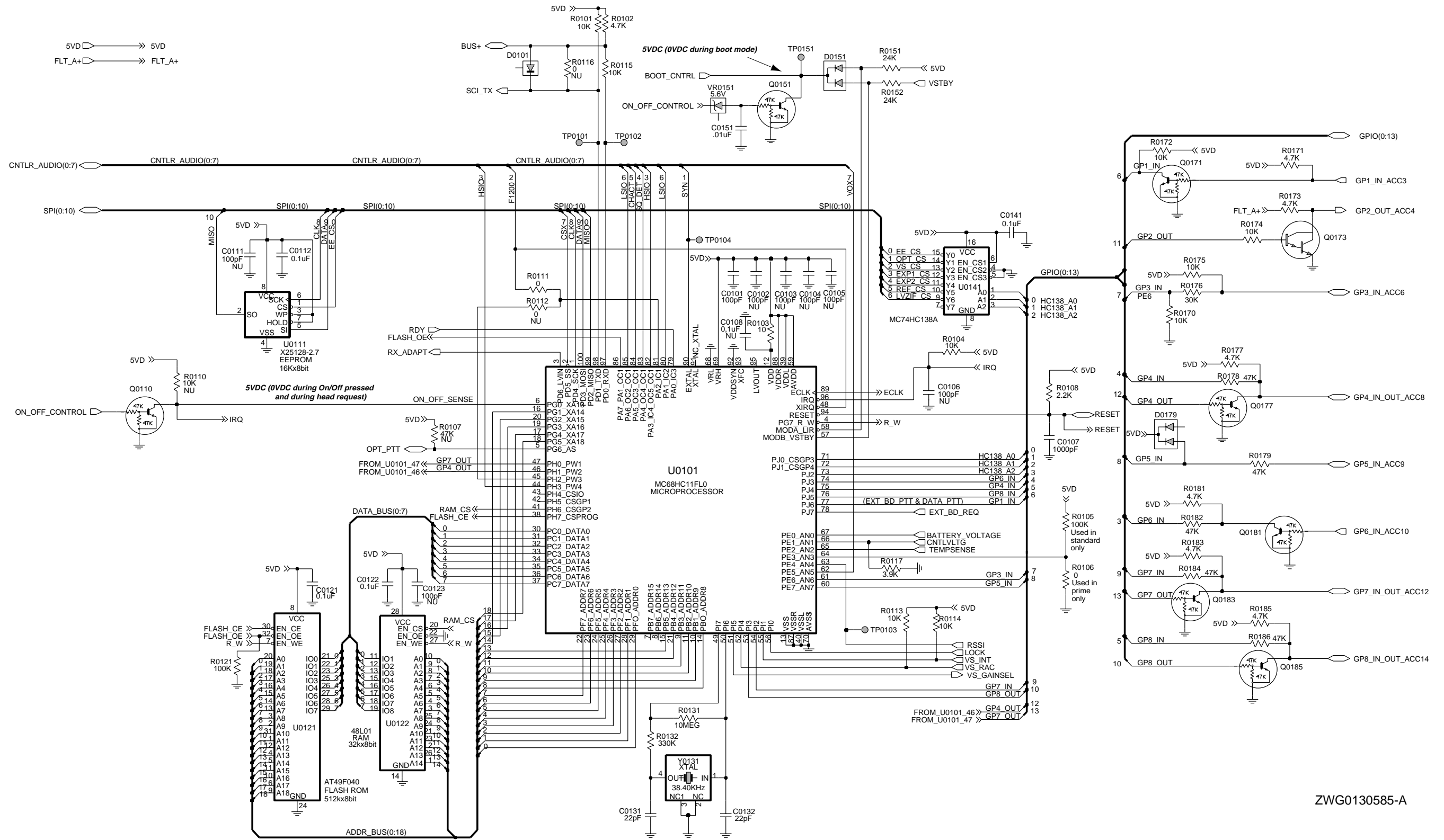

ZWG0130585-A

Controller T9 Schematic Diagram - Microprocessor

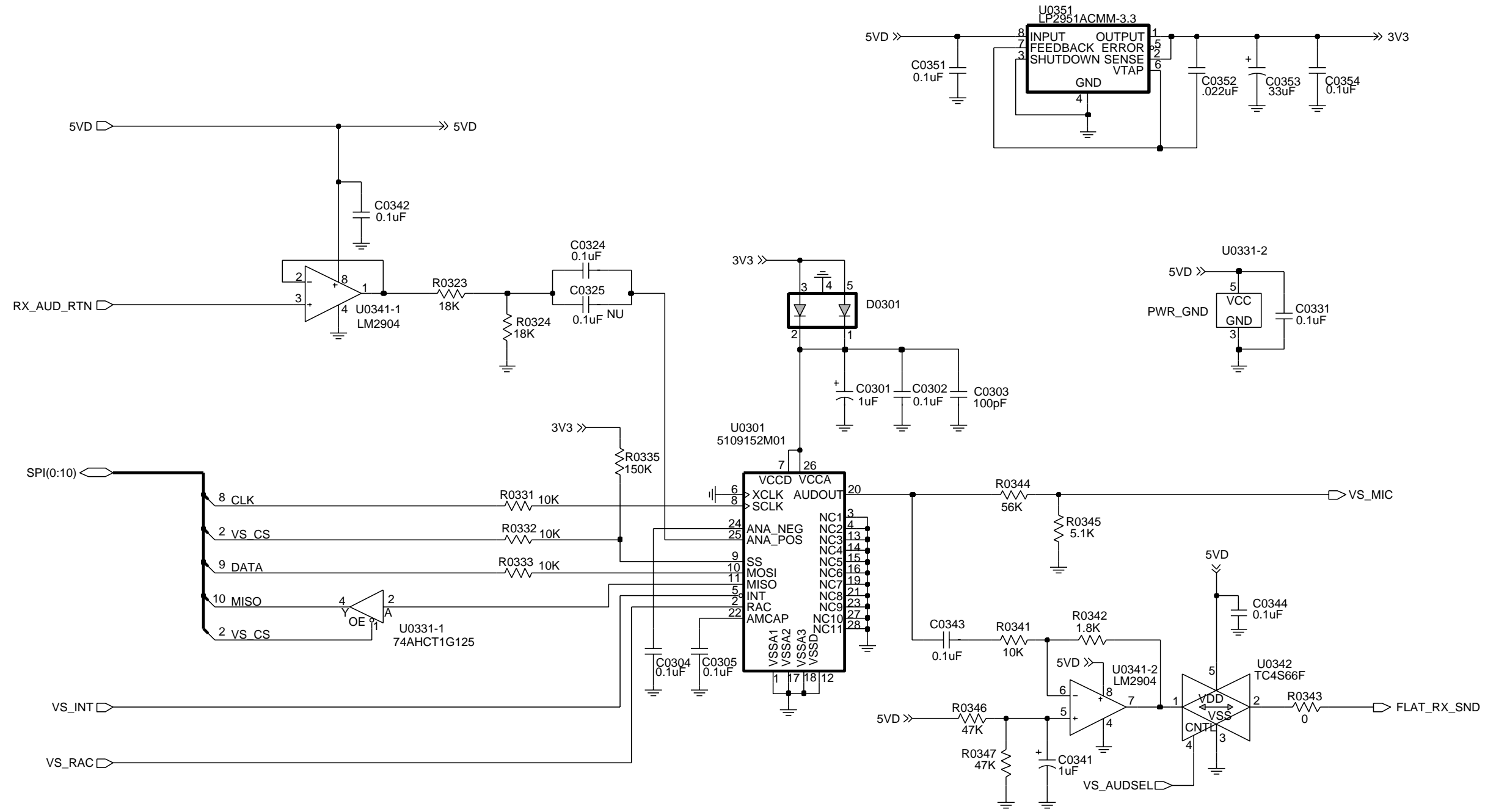

ZWG0130530-O

Controller T9 Schematic Diagram - Voice Storage

5.1 Controller T9 Parts List

Circuit Ref	Motorola Part No	Description
C0101	2113740F51	100pF 5% 50V
C0107	2113741F25	1nF 50V
C0112	2113743E20	100nF 16V
C0121	2113743E20	100nF 16V
C0122	2113743E20	100nF 16V
C0131	2113740F35	22pF 5% 50V
C0132	2113740F35	22pF 5% 50V
C0141	2113743E20	100nF 16V
C0151	2113741F49	10nF 50V
C0201	2311049A57	10uF 10% 16V
C0202	2311049A57	10uF 10% 16V
C0204	2113743E20	100nF 16V
C0212	2311049A57	10uF 10% 16V
C0221	2113743E20	100nF 16V
C0222	2113743E20	100nF 16V
C0223	2113743E20	100nF 16V
C0224	2113740F51	100pF 5% 50V
C0225	2113743E20	100nF 16V
C0226	2113743E20	100nF 16V
C0228	2311049A56	4.7uF 10% 16V
C0231	2113743B29	1 uF 10% 16V
C0232	2113743E20	100nF 16V
C0234	2113743E20	100nF 16V
C0235	2113743E07	22nF 16V
C0236	2113743E10	.033UF 10%
C0241	2113743E20	100nF 16V
C0243	2113740F51	100pF 5% 50V
C0244	2113743E20	100nF 16V
C0245	2113743E20	100nF 16V
C0246	2113741F49	10nF 50V
C0251	2113743E20	100nF 16V
C0252	2311049A07	1uF 10% 16V
C0254	2113743E20	100nF 16V
C0255	2113743E20	100nF 16V
C0256	2113740F51	100pF 5% 50V
C0261	2113743E20	100nF 16V
C0262	2113740F49	82pF 5% 50V NPO
C0265	2113743E20	100nF 16V
C0267	2113741F49	10nF 50V
C0271	2113741F49	10nF 50V
C0272	2113743E20	100nF 16V
C0273	2113741F37	3.3nF 50V
C0275	2311049A99	47uF 20% 10V
C0276	2113741F25	1nF 50V X7R
C0277	2113741F25	1nF 50V X7R
C0290	2311049C01	10uF (only LowBand)
C0291	2311049C01	10uF (only LowBand)
C0292	2311049C01	10uF (only LowBand)
C0293	2311049C01	10uF (only LowBand)

Circuit Ref	Motorola Part No	Description
C0301	2311049A07	TANT CP 1uF 10% 16V
Used in	GM1280 only	
C0302	2113743E20	100nF 16V
Used in	GM1280 only	
C0303	2113740F51	100pF 5% 50V
Used in	GM1280 only	
C0304	2113743E20	100nF 16V
Used in	GM1280 only	
C0305	2113743E20	100nF 16V
Used in	GM1280 only	
C0324	2113743E20	100nF 16V
Used in	GM1280 only	
C0331	2113743E20	100nF 16V
Used in	GM1280 only	
C0341	2311049A07	TANT CP 1uF 10% 16V
Used in	GM1280 only	
C0342	2113743E20	100nF 16V
Used in	GM1280 only	
C0343	2113743E20	100nF 16V
Used in	GM1280 only	
C0344	2113743E20	100nF 16V
Used in	GM1280 only	
C0351	2113743E20	100nF 16V
Used in	GM1280 only	
C0352	2113743E07	22nF 16V
Used in	GM1280 only	
C0353	2311049A97	TANT CHIP 33 UF
Used in	GM1280 only	
C0354	2113743E20	100nF 16V
Used in	GM1280 only	
C0421	2113743N48	82.0 PF 5%
C0422	2113741F17	470pF 50V
C0423	2113741F17	470pF 50V
C0426	2113743L09	470 PF 10%
C0427	2113743L09	470 PF 10%
C0428	2113743N48	82.0 PF 5%
C0429	2113743L09	470 PF 10%
C0430	2113741F17	470pF 50V
C0431	2113741F17	470pF 50V
C0441	2113743L09	470 PF 10%
C0442	2113743L09	470 PF 10%
C0445	2113743L09	470 PF 10%
C0446	2113743L09	470 PF 10%
C0447	2113743L09	470 PF 10%
C0448	2113743L09	470 PF 10%
C0449	2113743L09	470 PF 10%
C0470	2113743L09	470 PF 10%
C0471	2113743N48	82.0 PF 5%
C0472	2113743N48	82.0 PF 5%
C0473	2113743N48	82.0 PF 5%
C0474	2113743L09	470 PF 10%
C0476	2113743L09	470 PF 10%
C0477	2113743L09	470 PF 10%

Circuit Ref	Motorola Part No	Description
C0478	2113743L09	470 PF 10%
C0482	2113743L09	470 PF 10%
C0483	2113743L09	470 PF 10%
C0484	2113741F17	470pF 50V
C0485	2113743L09	470 PF 10%
C0486	2113743L09	470 PF 10%
C0487	2113743L09	470 PF 10%
C0488	2113743L09	470 PF 10%
C0490	2113743L09	470 PF 10%
C0491	2113743L09	470 PF 10%
C0492	2113743L09	470 PF 10%
C0493	2113743L09	470 PF 10%
C0494	2113743L09	470 PF 10%
C0495	2113743L09	470 PF 10%
C0496	2113743L09	470 PF 10%
C0497	2113743L09	470 PF 10%
C0499	2113743L09	470 PF 10%
C0501	2113741F49	10nF 50V
C0502	2113741F17	470pF 50V
C0503	2113741F17	470pF 50V
C0504	2113741F17	470pF 50V
C0505	2113741F17	470pF 50V
C0506	2113741F17	470pF 50V
C0508	2113741F17	470pF 50V (
C0509	2113741F17	470pF 50V
C0510	2113741F17	470pF 50V
C0511	2113741F17	470pF 50V
C0512	2113741F17	470pF 50V
C0513	2113741F17	470pF 50V
C0514	2113741F17	470pF 50V
C0515	2113741F17	470pF 50V
C0516	2113741F49	10nF 50V
C0517	2113743N48	82.0 PF 5%
C0518	2113741F17	470pF 50V
C0541	2311049A05	470nF 10% 25V
C0542	2311049A99	47uF 20% 10V
C0560	2113743L17	1nF 10%
C0591	2113743E20	100nF 16V
C0592	2113743E20	100nF 16V
C0593	2113741B69	100nF 50V
C0601	2113741F17	470pF 50V
C0603	2380090M24	LYT 10uF 50V 20%
C0611	2311049C06	CP 22uF 20% 35V
C0612	2113743E20	100nF 16V
C0622	2311049A99	CP 47uF 20%
C0641	2113741F17	470pF 50V
C0644	2311049A97	CHIP 33 UF
C0645	2113743E20	100nF 16VD
C0652	2311049A97	CHIP 33 UF 16
C0654	2311049A57	CP 10uF 10% 16V
C0655	2113743E20	100nF 16V

Circuit Ref	Motorola Part No	Description
C0661	2311049C05	CP 47uF 10% 16V
C0662	2113741F49	10nF 50V
C0663	2113743E20	100nF 16V
C0671	2113743E20	100nF 16V
C0681	2113743E20	100nF 16V
D0101	4813825A05	CHIP SCHOTTKY
D0151	4813833C02	DUAL SOT MMBD6100
D0179	4813833C02	DUAL SOT MMBD6100
D0301	4802245J47	SCHOTTKY BARRIER
Used in	GM1280 only	(RB471E)
D0621	4813833C02	DUAL SOT MMBD6100
D0651	4813833C02	DUAL SOT MMBD6100
D0660	4813833C02	DUAL SOT MMBD6100
D0661	4813833C02	DUAL SOT MMBD6100
E0271	2484657R01	Ferrite Bead
E0272	2484657R01	Ferrite Bead
E0631	2484657R01	Ferrite Bead
F0401	6580542Z01	3A 24V
J0401	0902636Y02	CONN FLEX 12 PIN
J0451	0902636Y01	CONN FLEX SIDE ENTRY
J0501	0986105B01	CONN SMD 20 PIN
J0551	0905505Y04	CONN ZIF HORIZONTAL
J0552	0905505Y03	CONN ZIF 18PIN
J0601	0986165B01	DC PWR CONN
Q0110	4880048M01	NPN DIG 47k/47k
Q0151	4880048M01	NPN DIG 47k/47k
Q0171	4880048M01	NPN DIG 47k/47k
Q0173	4880052M01	NPN DRLNGTN MXTA
Q0177	4880048M01	NPN DIG 47k/47k
Q0181	4880048M01	NPN DIG 47k/47k
Q0183	4880048M01	NPN DIG 47k/47k
Q0185	4880048M01	NPN DIG 47k/47k
Q0271	4880214G02	NPN 40V .2A
Q0641	4880048M01	NPN DIG 47k/47k
Q0661	4805921T02	DUAL ROHM FMC2 RH
Q0662	4880214G02	NPN 40V .2A B=50-150
Q0663	4880048M01	NPN DIG 47k/47k
Q0681	4880052M01	NPN DRLNGTN MXTA
R0101	0662057A73	10k 1/16W 5%
R0102	0662057A65	4k7 1/16W 5%
R0103	0662057A01	10 1/16W 5%
R0104	0662057A73	10k 1/16W 5%
R0105	0662057A97	100k 1/16W
Used in	GM140/160	GM340/360/640/660 only
R0106	0662057B47	0 1/16W
Used in		GM380/GM1280 only
R0108	0662057A57	2k2 1/16W 5%
R0111	0662057B47	0 1/16W 0306
R0113	0662057A73	10k 1/16W 5%
R0114	0662057A73	10k 1/16W 5%
R0115	0662057A73	10k 1/16W 5%
R0117	0662057A63	3k9 1/16W 5%

Circuit Ref	Motorola Part No	Description
R0121	0662057A97	100k 1/16W
R0131	0662057B46	10.0 MEG OHMS 5%
R0132	0662057B10	330k 1/16W 5%
R0151	0662057A82	24K 1/16W 5%
R0152	0662057A82	24K 1/16W 5%
R0170	0662057A73	10k 1/16W 5%
R0171	0662057A65	4k7 1/16W 5%
R0172	0662057A73	10k 1/16W 5%
R0173	0662057A65	4k7 1/16W 5%
R0174	0662057A73	10k 1/16W 5%
R0175	0662057A73	10k 1/16W 5%
R0176	0662057A84	30k 1/16W 5%
R0177	0662057A65	4k7 1/16W 5%
R0178	0662057A89	47k 1/16W 5%
R0179	0662057A89	47k 1/16W 5%
R0181	0662057A65	4k7 1/16W 5%
R0182	0662057A89	47k 1/16W 5%
R0183	0662057A65	4k7 1/16W 5%
R0184	0662057A89	47k 1/16W 5%
R0185	0662057A65	4k7 1/16W 5%
R0186	0662057A89	47k 1/16W 5%
R0201	0662057A25	100 1/16W 5%
R0202	0662057A43	560 1/16W 5%
R0203	0662057A25	100 1/16W 5%
R0204	0662057A43	560 1/16W 5%
R0205	0662057A73	10k 1/16W 5%
R0206	0662057A73	10k 1/16W 5%
R0207	0662057A57	2k2 1/16W 5%
R0208	0662057A57	2k2 1/16W 5%
R0211	0660076E70	FILM 7500
R0212	0660076E70	FILM 7500
R0221	0662057A82	24K 1/16W 5%
R0222	0662057A82	24K 1/16W 5%
R0223	0662057A84	30k 1/16W 5%
R0224	0662057A71	8k2 1/16W 5%
R0228	0662057B47	0 1/16W
R0229	0662057A01	10 1/16W 5%
R0241	0662057A89	47k 1/16W 5%
R0242	0662057B47	0 1/16W
R0251	0662057A89	47k 1/16W 5%
R0252	0662057A91	56K 1/16W 5%
R0253	0662057A97	100k 1/16W
R0254	0662057A73	10k 1/16W 5%
R0255	0662057A73	10k 1/16W 5%
R0256	0662057A97	100k 1/16W
R0257	0662057A57	2k2 1/16W 5%
R0261	0662057A73	10k 1/16W 5%
R0262	0662057B08	270k 1/16W
R0265	0662057A82	24K 1/16W 5%
R0267	0662057A89	47k 1/16W 5%
R0268	0662057A73	10k 1/16W 5%

Circuit Ref	Motorola Part No	Description
R0269	0662057A41	470 1/16W 5%
R0273	0662057A82	24K 1/16W 5%
R0275	0662057A73	10k 1/16W 5%
R0276	0662057A77	15k 1/16W 5%
R0323	0662057A79	18k 1/16W 5%
Used in	GM1280 only	
R0324	0662057A79	18k 1/16W 5%
Used in	GM1280 only	
R0331	0662057A73	10k 1/16W 5%
Used in	GM1280 only	
R0332	0662057A73	10k 1/16W 5%
Used in	GM1280 only	
R0333	0662057A73	10k 1/16W 5%
Used in	GM1280 only	
R0335	0662057B02	150k 1/16W
Used in	GM1280 only	
R0341	0662057A73	10k 1/16W
Used in	GM1280 only	
R0342	0662057A55	1k8 1/16W
Used in	GM1280 only	
R0343	0662057B47	0 1/16W
Used in	GM1280 only	
R0344	0662057A91	56K 1/16W
Used in	GM1280 only	
R0345	0662057A66	5k1 1/16W
Used in	GM1280 only	
R0346	0662057A89	47k 1/16W
Used in	GM1280 only	
R0347	0662057A89	47k 1/16W
Used in	GM1280 only	
R0401	0662057A33	220 1/16W
R0407	0662057M26	10 5% 20X40
R0408	0662057A25	100 1/16W 5%
R0409	0662057M26	10 5% 20X40
R0412	0662057B47	0 1/16W
R0441	0662057B47	0 1/16W
R0442	0662057A49	1k 1/16W 5%
R0467	0662057M26	10 5% 20X40
R0468	0662057A97	100k 1/16W
R0481	0662057B47	0 1/16W
R0482	0662057B47	0 1/16W
R0510	0662057A65	4k7 1/16W 5%
R0511	0662057A97	100k 1/16W
R0512	0662057A77	15k 1/16W 5%
R0525	0662057A97	100k 1/16W
R0529	0662057A89	47k 1/16W 5%
R0530	0662057A81	22k 1/16W 5%
R0531	0662057A43	560 1/16W 5%
R0533	0662057B47	0 1/16W
R0535	0662057A49	1k 1/16W 5%
R0537	0662057A33	220 1/16W 5%
R0538	0662057A33	220 1/16W 5%

Circuit Ref	Motorola Part No	Description
R0539	0662057A65	4k7 1/16W 5%
R0541	0662057A83	27k 1/16W 5%
R0543	0662057A97	100k 1/16W
R0555	0662057A25	100 1/16W 5%
R0556	0662057A25	100 1/16W 5%
R0591	0662057A82	24K 1/16W 5%
R0592	0662057A01	10 1/16W 5%
R0593	0662057A97	100k 1/16W
R0611	0662057A91	56K 1/16W
R0612	0662057A65	4k7 1/16W
R0621	0662057A82	24K 1/16W
R0641	0662057A73	10k 1/16W
R0642	0660076E70	FILM 7500
R0643	0660076E51	FILM 1200
R0651	0662057A01	10 1/16W 5%
R0652	0662057A01	10 1/16W 5%
R0661	0662057A49	1k 1/16W 5%
R0662	0662057B02	150k 1/16W
R0671	0662057A84	30k 1/16W 5%
R0672	0662057A73	10k 1/16W 5%
R0681	0662057A79	18k 1/16W 5%
R0682	0662057A93	68k 1/16W 5%
U0101	5102226J56	MICRO PROCESSOR MC68HC1 1FLO
* U0111	5102463J64	EEPROM X25128-2.7 SO8
* U0121	5186137B01	512KX8 FLASH ROM (AT49BV020)
U0122	5185748L01	32K x 8 SRAM
U0141	5113805A30	10F8 DCDR/REMUX 74HC138
U0211	5183222M49	QUAD OPAMP __ 3403
U0221	5185130C53	ASFICCOMP 0.5MM TQFP
U0251	5184704M60	MUX/DEMUX,TRIPLE 2-
U0271	5109699X01	AUDIO PA TDA1519C
U0301	5109152M01	EEPROM ANALOG
Used in	GM1280 only	ISD33120EI
U0331	5186204B01	BUFFER/DRIVER
Used in	GM1280 only	74AHCT1G125
U0341	5180932W01	LINEAR IC OP AMP
Used in	GM1280 only	
U0342	5105750U28	SNGL ANALOG SWITCH
Used in	GM1280 only	SMD
U0351	5102463J40	REGULATOR, 3.3V,
Used in	GM1280 only	LP2951CM-3.3
U0611	5183308X01	ADJ VLTG REG LM2941 TO263
U0641	5183308X01	ADJ VLTG REG LM2941 TO263
U0651	5113816A07	REG 5V POS 500MA MC78M05
U0652	5113815A02	MC33064
VR0151	4813830A15	5.6V 5% 225mW

Circuit Ref	Motorola Part No	Description
VR0501	4805656W09	ZENER QUAD MMQA20VT1
VR0503	4805656W09	ZENER QUAD MMQA20VT1
VR0504	4813830A40	SOC23 AUTO SDN
VR0505	4805656W09	ZENER QUAD MMQA20VT1
VR0509	4813830A40	SOC23 AUTO SDN
VR0510	4813830A40	SOC23 AUTO SDN
VR0537	4813830A15	5.6V 5% 225mW
VR0541	4813830A27	14V 5% 225MW
VR0601	4813832C77	TRANS SUP. 24V HIGH POWER
VR0621	4813830A15	5.6V 5% 225mW
Y0131	4880113R19	CRYSTAL 38.4KHz

* Motorola Depot Servicing only

Reference designators with an asterisk indicate components which are not fieldreplaceable because they need to be calibrated with specialized factory equipment after installation. Radios in which these parts have been replaced in the field will be off frequency at temperature extremes.



Professional Radio

GM Series

Controlhead
Service Information

Issue: February 2001

Computer Software Copyrights

The Motorola products described in this manual may include copyrighted Motorola computer programs stored in semiconductor memories or other media. Laws in the United States and other countries preserve for Motorola certain exclusive rights for copyrighted computer programs, including the exclusive right to copy or reproduce in any form, the copyrighted computer program. Accordingly, any copyrighted Motorola computer programs contained in the Motorola products described in this manual may not be copied or reproduced in any manner without the express written permission of Motorola. Furthermore, the purchase of Motorola products shall not be deemed to grant, either directly or by implication, estoppel or otherwise, any license under the copyrights, patents or patent applications of Motorola, except for the normal non-exclusive royalty-free license to use that arises by operation of law in the sale of a product.

Table of Contents

Chapter 1 MODEL OVERVIEW

1.0 GM140/GM340/GM640 Models	1-1
2.0 GM160/GM360/GM660 Models	1-1
3.0 GM380/GM1280 Models	1-2
4.0 Databox Models	1-2

Chapter 2 THEORY OF OPERATION

1.0 Introduction	2-1
2.0 Controlhead Model for GM140, GM340 and GM640	2-1
2.1 Power Supplies	2-1
2.2 Power On / Off	2-1
2.3 Microprocessor Circuit	2-1
2.4 SBEP Serial Interface	2-1
2.5 Keypad Keys	2-1
2.6 Status LED and Back Light Circuit	2-3
2.7 Microphone Connector Signals	2-3
2.8 Speaker	2-4
2.9 Electrostatic Transient Protection	2-4
3.0 Controlhead Model for GM160, GM360 and GM660	2-4
3.1 Power Supplies	2-4
3.2 Power On / Off	2-4
3.3 Microprocessor Circuit	2-5
3.4 SBEP Serial Interface	2-5
3.5 Keypad Keys	2-6
3.6 Status LED and Back Light Circuit	2-6
3.7 Liquid Crystal Display (LCD)	2-6
3.8 Microphone Connector Signals	2-6
3.9 Speaker	2-7
3.10 Electrostatic Transient Protection	2-8

4.0	Controlhead Model for GM380 and GM1280	2-8
4.1	Power Supplies.....	2-8
4.2	Voltage Regulator Circuit.....	2-8
4.3	Power On / Off.....	2-9
4.4	Microprocessor Circuit.....	2-9
4.5	SBEP Serial Interface.....	2-10
4.6	Keypad Keys.....	2-10
4.7	Status LED and Back Light Circuit	2-10
4.8	Liquid Crystal Display (LCD)	2-11
4.9	Microphone Connector Signals	2-11
4.10	Speaker	2-12
4.11	Electrostatic Transient Protection	2-12

Chapter 3 TROUBLESHOOTING CHARTS

1.0	Troubleshooting Chart for Controlhead GM140/340/640	3-1
1.1	On/Off	3-1
1.2	Microprocessor	3-2
2.0	Troubleshooting Chart for Controlhead GM160/360/660	3-3
2.1	On/Off	3-3
2.2	Microprocessor	3-4
2.3	Display	3-5
2.4	Backlight	3-6
3.0	Troubleshooting Chart for Controlhead GM380/1280	3-7
3.1	On/Off	3-7
3.2	Microprocessor	3-8
3.3	Microprocessor	3-9
3.4	Display	3-10
3.5	Keypad Backlight	3-11
3.6	Display Backlight	3-12

Chapter 4 CONTROLHEAD PCB/SCHEMATICS/PARTS LISTS

1.0	Allocation of Schematics and Circuit Boards	4-1
2.0	Controlhead GM140/340/640 - PCB 8486146B07 / Schematics	4-3
2.1	Controlhead PCB 8486146B07 - Parts List	4-6
3.0	Controlhead GM160/360/660 - PCB 8486155B06 / Schematics	4-7
3.1	Controlhead PCB 8486155B06 - Parts List	4-12
4.0	Controlhead GM380/1280 - PCB 8486178B03 / Schematics	4-13
4.1	Controlhead PCB 8486178B03 - Parts List	4-18

OVERVIEW

1.0 GM140/GM340/GM640 Models (GCN6112_)

The Controlhead contains the internal speaker, the on/off/volume knob, the microphone connector, several buttons to operate the radio and several indicator Light Emitting Diodes (LED) to inform the user about the radio status. To control the LED's and to communicate with the host radio the control head uses the Motorola 68HC11E9 microprocessor.



2.0 GM160/GM360/GM660 Models (GCN6114-GM160 / GCN6120-GM360/660)

The Controlhead contains the internal speaker, the on/off/volume knob, the microphone connector, several buttons to operate the radio, several indicator Light Emitting Diodes (LED) to inform the user about the radio status, and a 14 character Liquid Crystal Display (LCD) for alpha - numerical information e.g. channel number or call address name. To control the LED's and the LCD, and to communicate with the host radio the control head uses the Motorola 68HC11E9 microprocessor



3.0 GM380/GM1280 Models (GCN6121_)

The Controlhead contains the on/off/volume knob, the microphone connector, several buttons to operate the radio, several indicator Light Emitting Diodes (LED) to inform the user about the radio status, and a Liquid Crystal Display (LCD) with 21 pre - defined symbols and a 32*96 dot matrix for graphical or alpha - numerical information e.g. channel number, select code, call address name. To control the LED's and the LCD, and to communicate with the host radio the control head uses the Motorola 68HC11K4 microprocessor.



4.0 Databox Models (GCN6116_)

The Databox radios are transceiver models that have a databox radio blank head (a non-functional plastic cover) instead of a control head. These models are planned for special applications to be used mainly in conjunction with a radio modem.



THEORY OF OPERATION

1.0 Introduction

This Chapter provides a detailed theory of operation for the Controlhead circuits. For details of the trouble shooting refer to the related Section of this manual.

2.0 Controlhead Model for GM140, GM340 and GM640

The controlhead contains the internal speaker, the on/off/volume knob, the microphone connector, several buttons to operate the radio and several indicator Light Emitting Diodes (LED) to inform the user about the radio status. To control the LED's and to communicate with the host radio the controlhead uses the Motorola 68HC11E9 microprocessor.

2.1 Power Supplies

The power supply to the controlhead is taken from the host radio's FLT A+ voltage via connector J0801 pin 3 and the regulated +5V via connector J0801 pin 7. The voltage FLT A+ is at supply voltage level and is used for the LED's, the back light and to power up the radio via on / off / volume knob. The stabilized +5 volt is used for the microprocessor and the keypad buttons. The voltage USW 5V derived from the FLT A+ voltage and stabilized by the series combination of R0822, VR0822 is used to buffer the internal RAM of the microprocessor (U0831). C0822 allows the supply voltage level to be disconnected for a couple of seconds without losing RAM parameters. Dual diode D0822 prevents radio circuitry from discharging this capacitor. When the supply voltage is applied to the radio, C0822 is charged via R0822 and D0822. To avoid, that the μP enters the wrong mode when the radio is switched on while the voltage across C0822 is still too low, the regulated 5V charge C0822 via diode D0822.

2.2 Power On / Off

The On/Off/Volume knob when pressed switches the radio's voltage regulators on by connecting line ON OFF CONTROL to line UNSW 5V via D0821. Additionally, 5 volts at the base of digital transistor Q0822 informs the controlhead's microprocessor about the pressed knob. The microprocessor asserts pin 62 and line CH REQUEST low to hold line ON OFF CONTROL at 5 volts via Q0823 and D0821. The high line ON OFF CONTROL also informs the host radio, that the controlhead's microprocessor wants to send data via SBEP bus. When the radio returns a data request message, the microprocessor will inform the radio about the pressed knob. If the radio was switched off, the radio's μP will switch it on and vice versa. If the On/Off/Volume knob is pressed while the radio is on, the software detects a low state on line ON OFF SENSE, the radio is alerted via line ON OFF CONTROL and sends a data request message. The controlhead μP will inform the radio about the pressed knob and the radio's μP will switch the radio off.

2.3 Microprocessor Circuit

The controlhead uses the Motorola 68HC11E9 microprocessor (μP) (U0831) to control the LED's and to communicate with the host radio. RAM and ROM are contained within the microprocessor itself.

The microprocessor generates it's clock using the oscillator inside the microprocessor along with a 8 MHz ceramic resonator (U0833) and R0920.

The microprocessor's RAM is always powered to maintain parameters such as the last operating mode. This is achieved by maintaining 5V at μP pin 25. Under normal conditions, when the radio is off, USW 5V is formed by FLT A+ running to D0822. C0822 allows the battery voltage to be disconnected for a couple of seconds without losing RAM parameters. Diode D0822 prevents radio circuitry from discharging this capacitor.

There are 8 analogue to digital converter ports (A/D) on the μP . They are labeled within the device block as PE0-PE7. These lines sense the voltage level ranging from 0 to 5V of the input line and convert that level to a number ranging from 0 to 255 which can be read by the software to take appropriate action.

Pin VRH is the high reference voltage for the A/D ports on the μP . If this voltage is lower than +5V the A/D readings will be incorrect. Likewise pin VRL is the low reference for the A/D ports. This line is normally tied to ground. If this line is not connected to ground, the A/D readings will be incorrect.

The microprocessor can determine the used keypad type and the controlhead ID by reading the levels at ports PC0 – PC7. Connections JU0852/3/4 are provided by the individual keypads.

The MODB / MODA input of the μP must be at a logic „1" for it to start executing correctly. The XIRQ and the IRQ pins should also be at a logic „1".

Voltage sense device U0832 provides a reset output that goes to 0 volts if the regulated 5 volts goes below 4.5 volts. This is used to reset the controller to prevent improper operation.

2.4 SBEP Serial Interface

The host radio (master) communicates to the controlhead μP (slave) through its SBEP bus. This bus uses only line BUS+ for data transfer. The line is bi-directional meaning that either the radio or the controlhead μP can drive the line. The microprocessor sends serial data via pin 50 and D0831 and it reads serial data via pin 47. Whenever the microprocessor detects activity on the BUS+ line, it starts communication.

When the host radio needs to communicate to the controlhead μP , it sends data via line BUS+. Any transition on this line generates an interrupt and the μP starts communication. The host radio may send data like LED and back light status or it may request the controlhead ID or the keypad ID.

When the controlhead μP wants to communicate to the host radio, the μP brings request line CH REQUEST to a logic „0" via μP pin 62. This switches on Q0823, which pulls line ON OFF CONTROL high through diode D0821. A low to high transition on this line informs the radio, that the controlhead requires service. The host radio then sends a data request message via BUS+ and the controlhead μP replies with the data it wanted to send. This data can be information like which key has been pressed or that the volume knob has been rotated.

The controlhead μP monitors all messages sent via BUS+, but ignores any data communication between host radio and CPS or Universal Tuner.

2.5 Keypad Keys

The controlhead keypad is a 6 - key keypad. All keys are configured as 2 analogue lines read by μP pins 13 and 15. The voltage on the analogue lines varies between 0 volts and +5 volts depending on which key has been pressed. If no key is pressed, the voltage at both lines will be 5 volts. The key configuration can be thought of as a matrix, where the two lines represent one row and one column. Each line is connected to a resistive divider powered by +5 volts. If a button is pressed, it will connect one specific resistor of each divider line to ground level and thereby reduce the voltages on the analogue lines. The voltages of the lines are A/D converted inside the μP (ports PE 0 - 1) and specify the pressed button. To determine which key is pressed, the voltage of both lines must be considered.

An additional pair of analogue lines and A/D μP ports (PE 3 – 2) is available to support a keypad microphone, connected to the microphone connector J0811. Any microphone key press is processed the same way as a key press on the controlhead.

2.6 Status LED and Back Light Circuit

All indicator LED's (red, yellow, green) are driven by current sources. To change the LED status the host radio sends a data message via SBEP bus to the controlhead μP . The controlhead μP determines the LED status from the received message and switches the LED's on or off via port PB 7 – 0 and port PA4. The LED status is stored in the μP 's memory. The LED current is determined by the resistor at the emitter of the respective current source transistor.

The back light for the keypad is controlled by the host radio the same way as the indicator LED's using μP port PA 5. The μP can switch the back light on and off under software control. The keypad back light current is drawn from the FLT A+ source and controlled by 2 current sources. The LED current is determined by the resistor at the emitter of the respective current source transistor.

2.7 Microphone Connector Signals

Signals BUS+, PTT IRDEC, HOOK, MIC, HANDSET AUDIO, FLT A+, +5V and 2 A/D converter inputs are available at the microphone connector J0811. Signal BUS+ (J0811-7) connects to the SBEP bus for communication with the CPS or the Universal Tuner. Line MIC (J0811-5) feeds the audio from the microphone to the radio's controller via connector J0801-4. Line HANDSET AUDIO (J0811-8) feeds the receiver audio from the controller (J0801-6) to a connected handset. FLT A+, which is at supply voltage level, and +5V are used to supply any connected accessory like a microphone or a handset.

The 2 A/D converter inputs (J0811-9/10) are used for a microphone with keypad. A pressed key will change the dc voltage on both lines. The voltages depend on which key is pressed. The μP determines from the voltage on these lines which key is pressed and sends the information to the host radio.

Line PTT IRDEC (J0811-6) is used to key up the radio's transmitter. While the PTT button on a connected microphone is released, line PTT IRDEC is pulled to +5 volts level by R0843. Transistor Q0843 is switched on and causes a low at μP port PA2. When the PTT button is pressed, signal PTT IRDEC is pulled to ground level. This switches off Q0843 and the resulting high level at μP port PA2 informs the μP about the pressed PTT button. The μP will inform the host radio about any status change on the PTT IRDEC line via SBEP bus.

When line PTT IRDEC is connected to FLT A+ level, transistor Q0821 is switched on through diode VR0821 and thereby pulls the level on line ON OFF CONTROL to FLT A+ level. This switches on the radio and puts the radio's μP in bootstrap mode. Bootstrap mode is used to load the firmware into the radio's flash memory (See controller subsection for more details).

The HOOK input (J0811-3) is used to inform the μP when the microphone's hang-up switch is engaged. Dependent on the CPS programming the μP may take actions like turning the audio PA on or off. While the hang up switch is open, line HOOK is pulled to +5 volts level by R0841. Transistor Q0841 is switched on and causes a low at μP port PA1. When the HOOK switch is closed, signal HOOK is pulled to ground level. This switches off R0841 and the resulting high level at μP port PA1 informs the μP about the closed hang up switch. The μP will inform the host radio about any status change on the HOOK line via SBEP bus.

2.8 Speaker

The controlhead contains a speaker for the receiver audio. The receiver audio signal from the differential audio output of the audio amplifier located on the radio's controller is fed via connector J0801-10, 11 to the speaker connector P0801 pin 1 and pin 2. The speaker is connected to the speaker connector P0801. The controlhead speaker can be disconnected if an external speaker, connected on the accessory connector, is used.

2.9 Electrostatic Transient Protection

Electrostatic transient protection is provided for the sensitive components in the controlhead by diodes VR0811 VR00812 VR0816 - VR0817. The diodes limit any transient voltages to tolerable levels. The associated capacitors provide Radio Frequency Interference (RFI) protection.

3.0 Controlhead Model for GM160, GM360 and GM660

The controlhead contains the internal speaker, the on/off/volume knob, the microphone connector, several buttons to operate the radio, several indicator Light Emitting Diodes (LED) to inform the user about the radio status, and a 14 character Liquid Crystal Display (LCD) for alpha - numerical information e.g. channel number or call address name. To control the LED's and the LCD, and to communicate with the host radio the controlhead uses the Motorola 68HC11E9 microprocessor.

3.1 Power Supplies

The power supply to the controlhead is taken from the host radio's FLT A+ voltage via connector J0801 pin 3 and the regulated +5V via connector J0801 pin 7. The voltage FLT A+ is at battery level and is used for the LED's, the back light and to power up the radio via on / off / volume knob. The stabilized +5 volt is used for the microprocessor, the display, the display driver and the keypad buttons. The voltage USW 5V derived from the FLT A+ voltage and stabilized by the series combination of R0822, VR0822 is used to buffer the internal RAM of the microprocessor (U0831). C0822 allows the battery voltage to be disconnected for a couple of seconds without losing RAM parameters. Dual diode D0822 prevents radio circuitry from discharging this capacitor. When the supply voltage is applied to the radio, C0822 is charged via R0822 and D0822. To avoid that the μP enters the wrong mode when the radio is switched on while the voltage across C0822 is still too low, the regulated 5V charge C0822 via diode D0822.

3.2 Power On / Off

The On/Off/Volume knob when pressed switches the radio's voltage regulators on by connecting line ON OFF CONTROL to line UNSW 5V via D0821. Additionally, 5 volts at the base of digital transistor Q0822 informs the controlhead's microprocessor about the pressed knob. The microprocessor asserts pin 62 and line CH REQUEST low to hold line ON OFF CONTROL at 5 volts via Q0823 and D0821. The high line ON OFF CONTROL also informs the host radio, that the controlhead's microprocessor wants to send data via SBEP bus. When the radio returns a data request message, the microprocessor will inform the radio about the pressed knob. If the radio was switched off, the radio's μP will switch it on and vice versa. If the On/Off/Volume knob is pressed while the radio is on, the software detects a low state on line ON OFF SENSE, the radio is alerted via line ON OFF CONTROL and sends a data request message. The controlhead μP will inform the radio about the pressed knob and the radio's μP will switch the radio off.

3.3 Microprocessor Circuit

The controlhead uses the Motorola 68HC11E9 microprocessor (μ P) (U0831) to control the LED's and the LCD and to communicate with the host radio. RAM and ROM are contained within the microprocessor itself.

The microprocessor generates its clock using the oscillator inside the microprocessor along with a 8 MHz ceramic resonator (U0833) and R0920 .

The microprocessor's RAM is always powered to maintain parameters such as the last operating mode. This is achieved by maintaining 5V at μ P pin 25 . Under normal conditions, when the radio is off, USW 5V is formed by FLT A+ running to D0822. C0822 allows the battery voltage to be disconnected for a couple of seconds without losing RAM parameters. Diode D0822 prevents radio circuitry from discharging this capacitor.

There are 8 analogue to digital converter ports (A/D) on the μ P . They are labeled within the device block as PE0-PE7. These lines sense the voltage level ranging from 0 to 5V of the input line and convert that level to a number ranging from 0 to 255 which can be read by the software to take appropriate action.

Pin VRH is the high reference voltage for the A/D ports on the μ P . If this voltage is lower than +5V the A/D readings will be incorrect. Likewise pin VRL is the low reference for the A/D ports. This line is normally tied to ground. If this line is not connected to ground, the A/D readings will be incorrect.

The microprocessor can determine the used keypad type and the controlhead ID by reading the levels at ports PC0 – PC7. Connections JU0852/3/4 are provided by the individual keypads.

The MODB / MODA input of the μ P must be at a logic „1" for it to start executing correctly. The XIRQ and the IRQ pins should also be at a logic „1".

Voltage sense device U0832 provides a reset output that goes to 0 volts if the regulated 5 volts goes below 4.5 volts. This is used to reset the controller to prevent improper operation.

3.4 SBEP Serial Interface

The host radio (master) communicates to the controlhead μ P (slave) through its SBEP bus. This bus uses only line BUS+ for data transfer. The line is bi-directional, meaning that either the radio or the controlhead μ P can drive the line. The microprocessor sends serial data via pin 50 and D0831 and it reads serial data via pin 47. Whenever the microprocessor detects activity on the BUS+ line, it starts communication.

When the host radio needs to communicate to the controlhead μ P , it sends data via line BUS+. Any transition on this line generates an interrupt and the μ P starts communication. The host radio may send data like display information, LED and back light status or it may request the controlhead ID or the keypad ID.

When the controlhead μ P wants to communicate to the host radio, the μ P brings request line CH REQUEST to a logic „0" via μ P pin 62. This switches on Q0823, which pulls line ON OFF CONTROL high through diode D0821. A low to high transition on this line informs the radio, that the controlhead requires service. The host radio then sends a data request message via BUS+ and the controlhead μ P replies with the data it wanted to send. This data can be information like which key has been pressed or that the volume knob has been rotated.

The controlhead μ P monitors all messages sent via BUS+, but ignores any data communication between host radio and CPS or Universal Tuner.

3.5 Keypad Keys

The controlhead keypad is a 6-key keypad (Model B) or a 10-key keypad (model C). All keys are configured as 2 analogue lines read by μP pins 13 and 15. The voltage on the analogue lines varies between 0 volts and +5 volts depending on which key has been pressed. If no key is pressed, the voltage at both lines will be 5 volts. The key configuration can be thought of as a matrix, where the two lines represent one row and one column. Each line is connected to a resistive divider powered by +5 volts. If a button is pressed, it will connect one specific resistor of each divider line to ground level and thereby reduce the voltages on the analogue lines. The voltages of the lines are A/D converted inside the μP (ports PE 0 - 1) and specify the pressed button. To determine which key is pressed, the voltage of both lines must be considered.

An additional pair of analogue lines and A/D μP ports (PE 3 - 2) is available to support a keypad microphone, connected to the microphone connector J0811. Any microphone key press is processed the same way as a key press on the controlhead.

3.6 Status LED and Back Light Circuit

All the indicator LED's (red, yellow, green) are driven by current sources. To change the LED status the host radio sends a data message via SBEP bus to the controlhead μP . The controlhead μP determines the LED status from the received message and switches the LED's on or off via port PB 7 - 0 and port PA4. The LED status is stored in the μP 's memory. The LED current is determined by the resistor at the emitter of the respective current source transistor.

The back light for the LCD and the keypad is controlled by the host radio the same way as the indicator LED's using μP port PA 5. This port is a Pulse Width Modulator (PWM) output. The output signal charges capacitor C0843 through R0847. By changing the pulse width under software control, the dc voltage of C0843 and thereby, the brightness of the back light can be changed in four steps. The keypad back light current is drawn from the FLT A+ source and controlled by transistor Q0933. The current flowing through the LED's cause a proportional voltage drop across the parallel resistors R0947, R0948. This voltage drop is amplified by the op-amp U0931-2. U0931-2 and Q0934 form a differential amplifier. The voltage difference between the base of Q0934 and the output of U0931-2 determines the current from the base of the LED control transistor Q0933 and in turn the brightness of the LED's. The μP can control the LED's by changing the dc level at the base of Q0934. If the base of Q0934 is at ground level, Q0934 is switched off and no current flows through Q0933 and the LED's. If the base voltage of Q0934 rises a current flows through Q0934 and in turn through Q0933 causing the LED's to turn on and a rising voltage drop across R0947, R0948. The rising voltage causes the output of the op-amp to rise and to reduce the base to emitter voltage of Q0934. This decreases the current of Q0933 until the loop has settled.

3.7 Liquid Crystal Display (LCD)

The LCD H0971 uses the display driver U0971. The display is a single layer super twist nematic (STN) LCD display. It has 14 characters with a 5*8 dot matrix for displaying alpha - numerical information and a line with 21 pre - defined icons above the dot matrix

The driver contains a data interface to the μP , an LCD segment driver, an LCD power circuit, an oscillator, data RAM and control logic. At power up the driver's control logic is reset by a logic „0" at input SR2 (U0971-15). The driver's internal oscillator is set to about 20 kHz and can be measured at pin 22. The driver's μP interface is configured to accept 8 bit parallel data input (U0971-D0-D7) from the controlhead μP (U0831 port PC0-PC7).

To write data to the driver's RAM the μP sets chip select (U0971-20) to logic „0" via U0831-11, RD (U0971-18) to logic „1" via (U0831-10) and WR (U0971-17) to logic „0" via U0831-9. With input A0 (U0971-21) set to logic „0" via U0831-12 the μP writes control data to the driver. Control data

includes the RAM start address for the following display data. With input A0 set to logic „1" the μP then writes the display data to the display RAM. When data transfer is complete the μP terminates the chip select, RD and WD activities.

The display driver's power circuit provides the voltage supply for the display. This circuit consists of a voltage multiplier, voltage regulator and a voltage follower. The external capacitors C0971 - C0973 configure the multiplier to double the supply voltage. In this configuration the multiplier output VOUT (U0971-8) supplies a voltage of -5V ($2 \times -5\text{V}$ below VDD). The multiplied voltage VOUT is sent to the internal voltage regulator. To set the voltage level of the regulator output V5 (U0971-5) this voltage is divided by the resistors R0973 and R0974 and fed back to the reference input VR (U0971-6). In addition the regulator output voltage V5 can be controlled electronically by a control command sent to the driver. With the used configuration the voltage V5 is about -2V . The voltage V5 is resistively divided by the driver's voltage follower to provide the voltages V1 - V4. These voltages are needed for driving the liquid crystals. The level of V5 can be measured by one of the μP 's analogue to digital converters (U0831-20) via resistive divider R0975, R0976. To stabilize the display brightness over a large temperature range the μP measures the temperature via analogue to digital converter (U0831-18) using temperature sensor U0834. Dependent on the measured temperature the μP adjusts the driver output voltage V5, and in turn the display brightness, via parallel interface.

3.8 Microphone Connector Signals

Signals BUS+, PTT IRDEC, HOOK, MIC, HANDSET AUDIO, FLT A+, +5V and 2 A/D converter inputs are available at the microphone connector J0811. Signal BUS+ (J0811-7) connects to the SBEP bus for communication with the CPS or the Universal Tuner. Line MIC (J0811-5) feeds the audio from the microphone to the radio's controller via connector J0801-4. Line HANDSET AUDIO (J0811-8) feeds the receiver audio from the controller (J0801-6) to a connected handset. FLT A+, which is at supply voltage level, and +5V are used to supply any connected accessory like a microphone or a handset.

The 2 A/D converter inputs (J0811-9/10) are used for a microphone with keypad. A pressed key will change the dc voltage on both lines. The voltages depend on which key is pressed. The μP determines from the voltage on these lines which key is pressed and sends the information to the host radio.

Line PTT IRDEC (J0811-6) is used to key up the radio's transmitter. While the PTT button on a connected microphone is released, line PTT IRDEC is pulled to +5 volts level by R0843. Transistor Q0843 is switched on and causes a low at μP port PA2. When the PTT button is pressed, signal PTT IRDEC is pulled to ground level. This switches off Q0843 and the resulting high level at μP port PA2 informs the μP about the pressed PTT button. The μP will inform the host radio about any status change on the PTT IRDEC line via SBEP bus.

When line PTT IRDEC is connected to FLT A+ level, transistor Q0821 is switched on through diode VR0821 and thereby pulls the level on line ON OFF CONTROL to FLT A+ level. This switches on the radio and puts the radio's μP in bootstrap mode. Bootstrap mode is used to load the firmware into the radio's flash memory (See controller sub section for more details).

The HOOK input (J0811-3) is used to inform the μP when the microphone's hang-up switch is engaged. Dependent on the CPS programming the μP may take actions like turning the audio PA on or off. While the hang up switch is open, line HOOK is pulled to +5 volts level by R0841. Transistor Q0841 is switched on and causes a low at μP port PA1. When the HOOK switch is closed, signal HOOK is pulled to ground level. This switches off R0841 and the resulting high level at μP port PA1 informs the μP about the closed hang up switch. The μP will inform the host radio about any status change on the HOOK line via SBEP bus.

3.9 Speaker

The controlhead contains a speaker for the receiver audio. The receiver audio signal from the differential audio output of the audio amplifier located on the radio's controller is fed via connector J0801-10, 11 to the speaker connector P0801 pin 1 and pin 2. The speaker is connected to the speaker connector P0801. The controlhead speaker can be disconnected if an external speaker, connected on the accessory connector, is used.

3.10 Electrostatic Transient Protection

Electrostatic transient protection is provided for the sensitive components in the controlhead by diodes VR0811 VR0812 VR0816 - VR0817. The diodes limit any transient voltages to tolerable levels. The associated capacitors provide Radio Frequency Interference (RFI) protection.

4.0 Controlhead Model for GM380, and GM1280

The controlhead contains the on/off/volume knob, the microphone connector, several buttons to operate the radio, several indicator Light Emitting Diodes (LED) to inform the user about the radio status, and a Liquid Crystal Display (LCD) with 21 pre - defined symbols and a 32*96 dot matrix for graphical or alpha - numerical information e.g. channel number, select code, call address name. To control the LED's and the LCD, and to communicate with the host radio the controlhead uses the Motorola 68HC11K4 microprocessor.

4.1 Power Supplies

The power supply to the controlhead is taken from the host radio's FLT A+ voltage via connector J0801 pin 3. The voltage FLT A+ is at battery level and is used for the LED's, the back light, to power up the radio via on / off / volume knob and to supply the voltage regulator circuitry. The regulator circuitry provides the stabilized +5 volts which is used for the microprocessor circuitry, the display, the display driver and the keypad buttons. The regulated +5V taken from the host radio via connector J0801 pin 7 (line 5V SOURCE) is only used to switch on or off the voltage regulator in the controlhead.

4.2 Voltage Regulator Circuit

Voltage regulator U0861 provides 5V for the controlhead. The supply voltage FLT A+ for the voltage regulator is fed via parallel resistors R0861/2 and dual diode D0861 to pin 8 of U0861. The +5 volt output is switched on and off by the host radio's 5 volt source via line 5V SOURCE and control transistor Q0866. When the host radio is switched off the voltage on line +5V SOURCE is at ground level and switches off transistor Q0866. Pull up resistor R0863 pulls input SHUTDOWN (pin 3) of the voltage regulator U0861 to FLT A+ level and switches off the output of U0861 (pin 1). When the host radio is switched on the voltage on line 5V SOURCE of about +5 volts switches on transistor Q0866 which in turn pulls input SHUTDOWN (pin 3) to ground and switches on the output of U0861. Input and output capacitors (C0861 / C0862 and C0864 / C0865) are used to reduce high frequency noise and provide proper operation during battery transients. Diode D0861 prevents discharge of C0862 by negative spikes on the FLT A+ voltage. This regulator provides a reset output (pin 5) that goes to 0 volts if the regulator output goes out of regulation. This is used to reset the microprocessor (U0871) and the display driver (J0821-5) to prevent improper operation.

The voltage USW 5V derived from voltage FLT A+ is stabilized using resistor R0855 and diode VR0855. This voltage is used to buffer the microprocessor's internal RAM. C0856 allows the battery voltage to be disconnected for a couple of seconds without losing RAM parameters. Diode D0855

prevents radio circuitry from discharging this capacitor. The +5V at the second anode of D0855 speeds up charging of C0856, when the host radio is turned on by a high level at the ignition input while the supply voltage is applied to the radio. This prevents the microprocessor from accidentally entering bootstrap mode.

4.3 Power On / Off

The On/Off/Volume knob when pressed switches the radio's and the controlhead's voltage regulators on by connecting line ON OFF CONTROL to line UNSW 5V via D0852. Additionally, 5 volts at the base of digital transistor Q0853 informs the controlhead's microprocessor about the pressed knob. The microprocessor asserts pin 8 and line CH REQUEST low to hold line ON OFF CONTROL at 5 volts via Q0852 and D0852. The high line ON OFF CONTROL also informs the host radio, that the controlhead's microprocessor wants to send data via SBEP bus. When the radio returns a data request message, the microprocessor will inform the radio about the pressed knob. If the radio was switched off, the radio's μ P will switch it on and vice versa. If the On/Off/Volume knob is pressed while the radio is on, the software detects a low state on line ON OFF SENSE, the radio is alerted via line ON OFF CONTROL and sends a data request message. The controlhead μ P will inform the radio about the pressed knob and the radio's μ P will switch the radio off. If the radio is switched on either manually or automatically it's +5V source switches on the controlhead's voltage regulator U0861 via line 5 SOURCE and transistor Q0866 and the controlhead's microprocessor starts execution.

4.4 Microprocessor Circuit

The controlheadcontrolhead uses the Motorola 68HC11K4 microprocessor (μ P) (U0871) to control the LED's and the LCD and to communicate with the host radio. RAM and ROM are contained within the microprocessor itself.

The microprocessor generates it's clock using the oscillator inside the microprocessor along with a 8 MHz ceramic resonator (U0873) and R0873.

The microprocessor's RAM is always powered to maintain parameters such as the last operating mode. This is achieved by maintaining 5V at μ P pin 76. Under normal conditions, when the radio is off, USW 5V is formed by FLT A+ running to D0855. C0856 allows the battery voltage to be disconnected for a couple of seconds without losing RAM parameters. Diode D0855 prevents radio circuitry from discharging this capacitor.

There are 8 analogue to digital converter ports (A/D) on the μ P. They are labeled within the device block as PE0-PE7. These lines sense the voltage level ranging from 0 to 5V of the input line and convert that level to a number ranging from 0 to 255 which can be read by the software to take appropriate action.

Pin VRH is the high reference voltage for the A/D ports on the μ P. If this voltage is lower than +5V the A/D readings will be incorrect. Likewise pin VRL is the low reference for the A/D ports. This line is normally tied to ground. If this line is not connected to ground, the A/D readings will be incorrect.

The microprocessor can determine the used keypad type by reading the level at port PE5. Connections S0931 – S0935 are provided by the individual keypads.

The MODB / MODA input of the μ P must be at a logic „1" for it to start executing correctly. The XIRQ and the IRQ pins should also be at a logic „1".

4.5 SBEP Serial Interface

The host radio (master) communicates to the controlhead μ P (slave) through its SBEP bus. This bus uses only line BUS+ for data transfer. The line is bi-directional, meaning that either the radio or the

controlhead μP can drive the line. The microprocessor sends serial data via pin 79 and D0872 and it reads serial data via pin 78. Whenever the microprocessor detects activity on the BUS+ line, it starts communication.

When the host radio needs to communicate to the controlhead μP , it sends data via line BUS+. Any transition on this line generates an interrupt and the μP starts communication. The host radio may send data like display information, LED and back light status or it may request the controlhead ID or the keypad ID.

When the controlhead μP wants to communicate to the host radio, the μP brings request line CH REQUEST to a logic „0" via μP pin 8. This switches on Q0852, which pulls line ON OFF CONTROL high through diode D0852. A low to high transition on this line informs the radio, that the controlhead requires service. The host radio then sends a data request message via BUS+ and the controlhead μP replies with the data it wanted to send. This data can be information like which key has been pressed or that the volume knob has been rotated.

The controlhead μP monitors all messages sent via BUS+, but ignores any data communication between host radio and CPS or Universal Tuner.

4.6 Keypad Keys

The controlhead keypad is a 25 - key keypad. All keys are configured as 2 analogue lines read by μP pins 49 and 48. The voltage on the analogue lines varies between 0 volts and +5 volts depending on which key has been pressed. If no key is pressed, the voltage at both lines will be 5 volts. The key configuration can be thought of as a matrix, where the two lines represent one row and one column. Each line is connected to a resistive divider powered by +5 volts. If a button is pressed, it will connect one specific resistor of each divider line to ground level and thereby reduce the voltages on the analogue lines. The voltages of the lines are A/D converted inside the μP (ports PE 0 - 1) and specify the pressed button. To determine which key is pressed, the voltage of both lines must be considered.

An additional pair of analogue lines and A/D μP ports (PE 3 - 2) is available to support a keypad microphone, connected to the microphone connector J0811. Any microphone key press is processed the same way as a key press on the controlhead.

4.7 Status LED and Back Light Circuit

All the indicator LED's (red, yellow, green) are driven by current sources. To change the LED status the host radio sends a data message via SBEP bus to the controlhead μP . The controlhead μP determines the LED status from the received message and switches the LED's on or off via port PA 6 - 4. The LED status is stored in the μP 's memory. The LED current is determined by the resistor at the emitter of the respective current source transistor.

The back light for keypad is controlled by the host radio the same way as the indicator LED's using μP port PH 3. This port is a Pulse Width Modulator (PWM) output. The output signal charges capacitor C0943 through R0945. By changing the pulse width under software control, the dc voltage of C0943 and thereby, the brightness of the back light can be changed in 16 steps. The keypad back light current is drawn from the FLT A+ source and controlled by transistor Q0941. The current flowing through the LED's cause a proportional voltage drop across the parallel resistors R0955, R0957. This voltage drop is amplified by the op-amp U0941-1. U0941-1 and Q0943 form a differential amplifier. The voltage difference between the base of Q0943 and the output of U0941-1 determines the current from the base of the LED control transistor Q0941 and in turn the brightness of the LED's. The μP can control the LED's by changing the dc level at the base of Q0943. If the base of Q0943 is at ground level, Q0943 is switched off and no current flows through Q0941 and the LED's. If the base voltage of Q0943 rises a current flows through Q0943 and in turn through Q0941 causing the LED's to turn on and a rising voltage drop across R0955, R0957. The rising voltage causes the

output of the op-amp to rise and to reduce the base to emitter voltage of Q0943. This decreases the current of Q0941 until the loop has settled.

The back light for the LCD module uses a similar circuitry. The only differences are that μ P port PH2 controls the back light brightness and that the LED's are located on the LCD module which is connected via J0821. Control line BL A GREEN connects to the anodes and control line BL K GREEN connects to the cathodes of the LED's.

4.8 Liquid Crystal Display (LCD)

The LCD module consists of the display and the display driver and is connected via connector J0821. The display is a single layer super twist nematic (STN) LCD display. It has a dot matrix of 32 * 96 dots for displaying graphics and alpha - numerical information and a line with 21 pre - defined icons above the dot matrix

The driver contains a data interface to the μ P, an LCD segment driver, an LCD power circuit, an oscillator, data RAM and control logic. At power up the driver's control logic is reset by a logic „0" via pin 5 of J0821. The driver's μ P interface is configured to accept 8 bit parallel data input (J0821-D0-D7) from the controlhead μ P (U0871 port PC0-PC7).

To write data to the driver's RAM the μ P sets chip select (J0821-6) to logic „0" via U0871-26, RD (J0821-10) to logic „1" via (U0871-40) and WR (U0821-9) to logic „0" via U0871-33. With input A0 (J0821-8) set to logic „0" via U0871-34 the μ P writes control data to the driver. Control data includes the RAM start address for the following display data. With input A0 set to logic „1" the μ P then writes the display data to the display RAM. When data transfer is complete the μ P terminates the chip select and the clock activities.

The display driver's power circuit provides the voltage supply for the display. This circuit consists of a voltage multiplier, voltage regulator and a voltage follower. The regulator output voltage for the display can be controlled electronically by a control command sent to the driver. The voltage level can be measured by one of the μ P's analogue to digital converters (U0871-42) via J0821-21. To stabilize the display brightness over a large temperature range the μ P measures the temperature via analogue to digital converter (U0871-43) using a temperature sensor on the module (J0821-4). Dependent on the measured temperature the μ P adjusts the driver output voltage, and in turn the display brightness, via parallel interface.

4.9 Microphone Connector Signals

Signals BUS+, PTT IRDEC, HOOK, MIC, HANDSET AUDIO, FLT A+, +5V and 2 A/D converter inputs are available at the microphone connector J0811. Signal BUS+ (J0811-7) connects to the SBEP bus for communication with the CPS or the Universal Tuner. Line MIC (J0811-5) feeds the audio from the microphone to the radio's controller via connector J0801-4. Line HANDSET AUDIO (J0811-8) feeds the receiver audio from the controller (J0801-6) to a connected handset. FLT A+, which is at supply voltage level, and +5V are used to supply any connected accessory like a microphone or a handset.

The 2 A/D converter inputs (J0811-9/10) are used for a microphone with keypad. A pressed key will change the dc voltage on both lines. The voltages depend on which key is pressed. The μ P determines from the voltage on these lines which key is pressed and sends the information to the host radio.

Line PTT IRDEC (J0811-6) is used to key up the radio's transmitter. While the PTT button on a connected microphone is released, line PTT IRDEC is pulled to +5 volts level by R0880. Transistor Q0871 is switched on and causes a low at μ P port PA2. When the PTT button is pressed, signal PTT IRDEC is pulled to ground level. This switches off Q0871 and the resulting high level at μ P port PA2

informs the μ P about the pressed PTT button. The μ P will inform the host radio about any status change on the PTT IRDEC line via SBEP bus.

When line PTT IRDEC is connected to FLT A+ level, transistor Q0851 is switched on through diode VR0851 and thereby pulls the level on line ON OFF CONTROL to FLT A+ level. This switches on the radio and puts the radio's μ P in bootstrap mode. Bootstrap mode is used to load the firmware into the radio's flash memory (See controller sub section for more details).

The HOOK input (J0811-3) is used to inform the μ P when the microphone's hang-up switch is engaged. Dependent on the CPS programming the μ P may take actions like turning the audio PA on or off. While the hang up switch is open, line HOOK is pulled to +5 volts level by R0883. Transistor Q0872 is switched on and causes a low at μ P port PA1. When the HOOK switch is closed, signal HOOK is pulled to ground level. This switches off R0883 and the resulting high level at μ P port PA1 informs the μ P about the closed hang up switch. The μ P will inform the host radio about any status change on the HOOK line via SBEP bus.

4.10 Speaker (Remote Mount Configuration only)

The remote mount controlhead contains a speaker for the receiver audio. The receiver audio signal from the differential audio output of the audio amplifier located on the radio's controller is fed via connector J0801-10,11 to the speaker connector P0801 pin 1 and pin 2. The speaker is connected to the speaker connector P0801. The controlhead speaker can be disconnected if only an external speaker, connected on the accessory connector, should be used. If the controlhead is mounted directly on the radio, an external speaker is required.

4.11 Electrostatic Transient Protection

Electrostatic transient protection is provided for the sensitive components in the controlhead by diodes VR0811 - VR0814. The diodes limit any transient voltages to tolerable levels. The associated capacitors provide Radio Frequency Interference (RFI) protection.

TROUBLESHOOTING CHARTS

1.0 Controlhead GM140/340/640 Troubleshooting Chart

1.1 On/Off

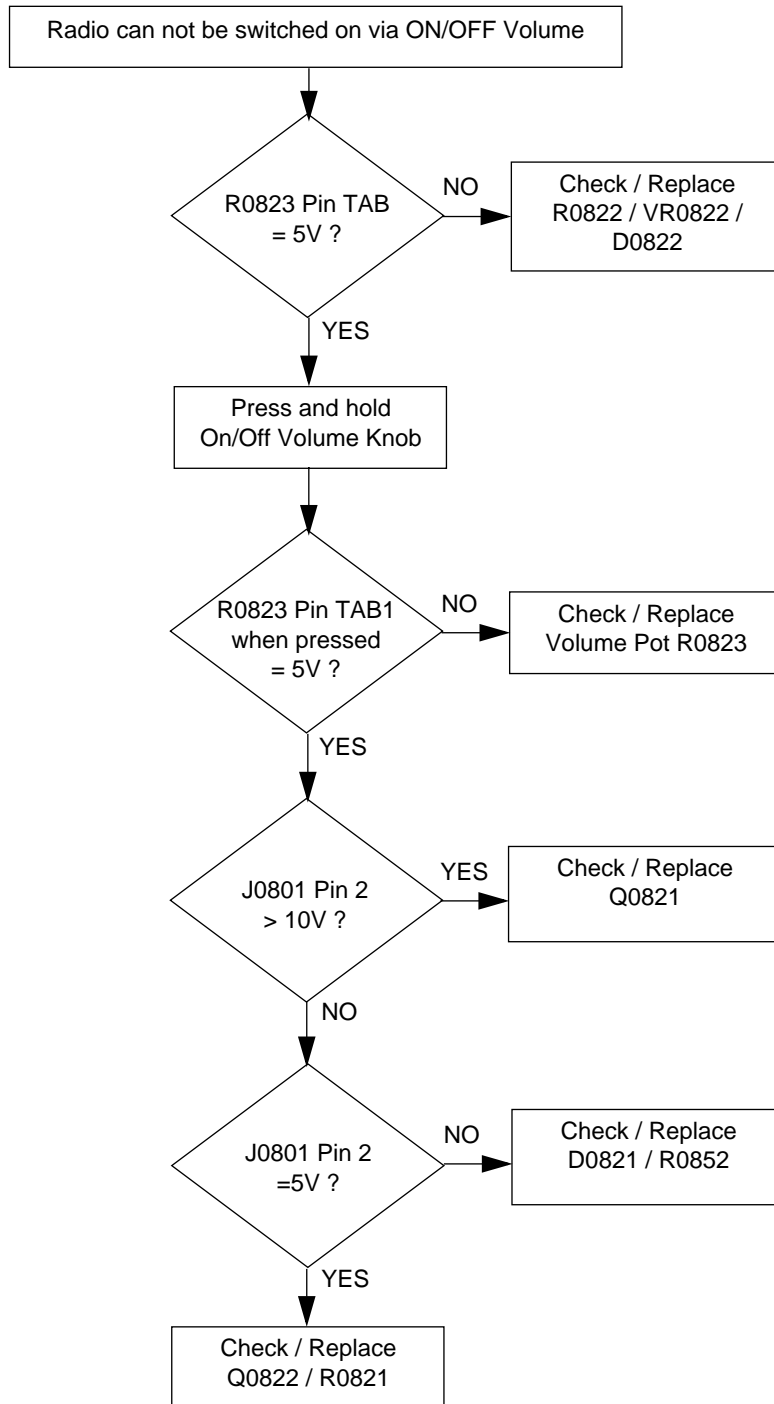

1.2 Microprocessor

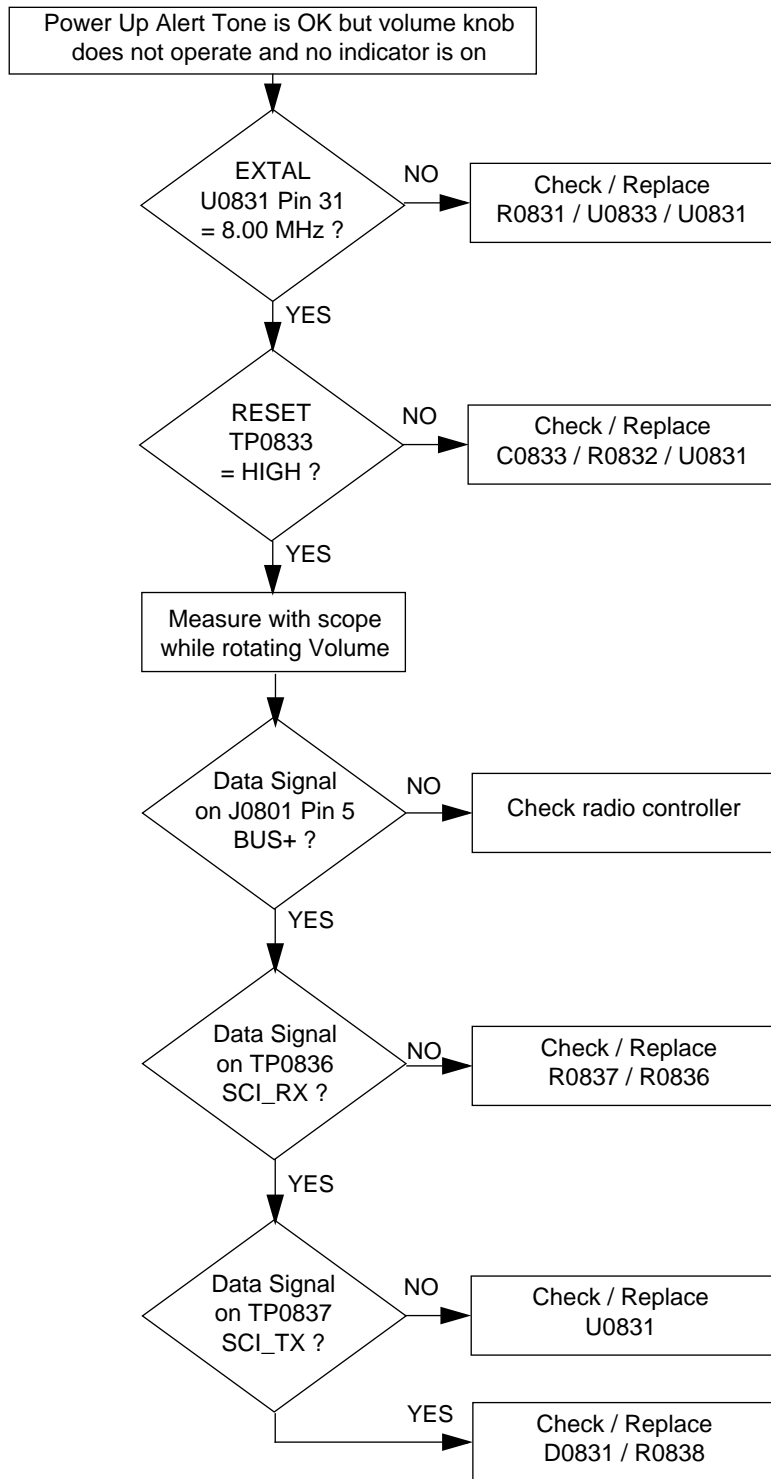

2.0 Controlhead GM160/360/660 Troubleshooting Flow Chart

2.1 On/Off

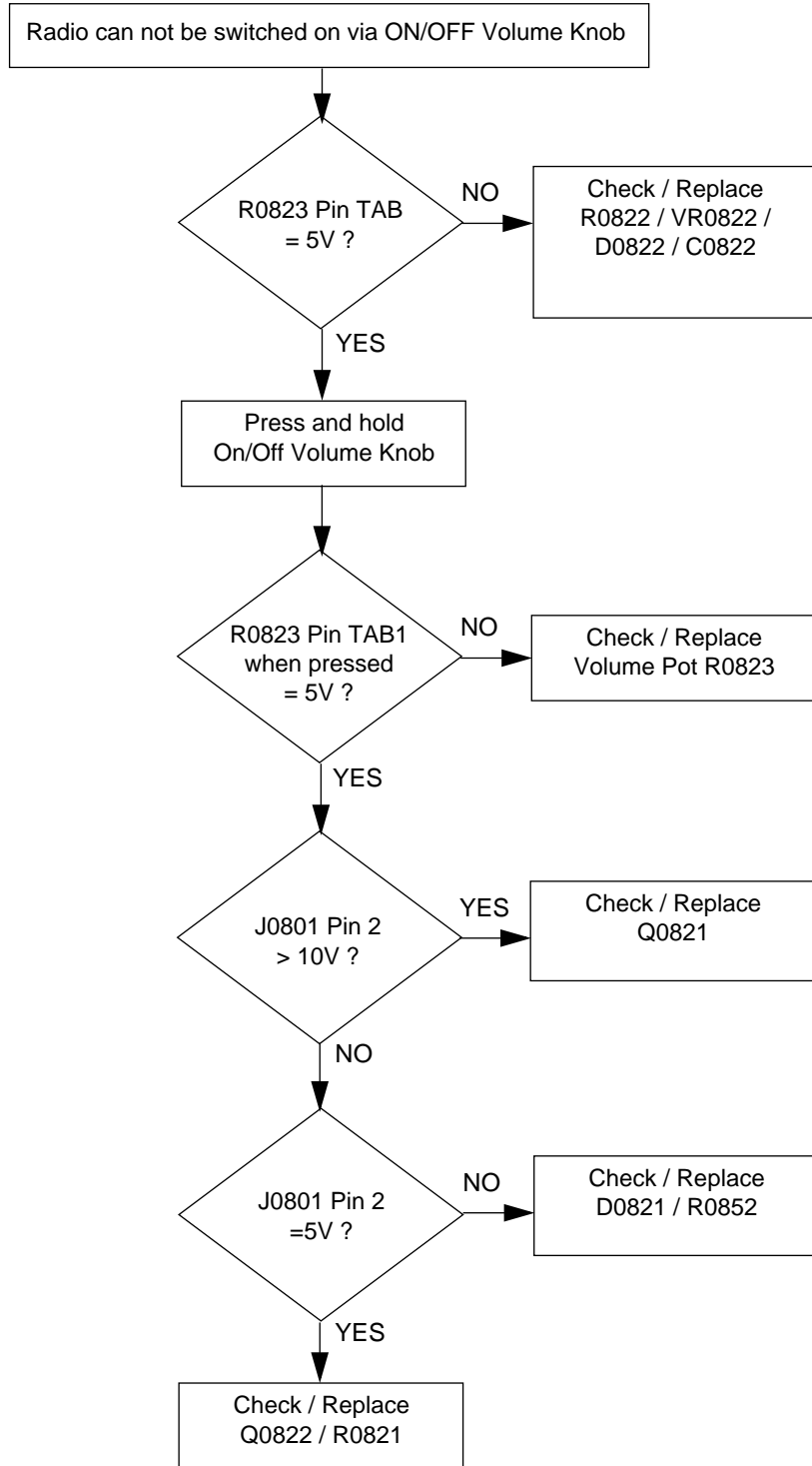

2.2 Microprocessor

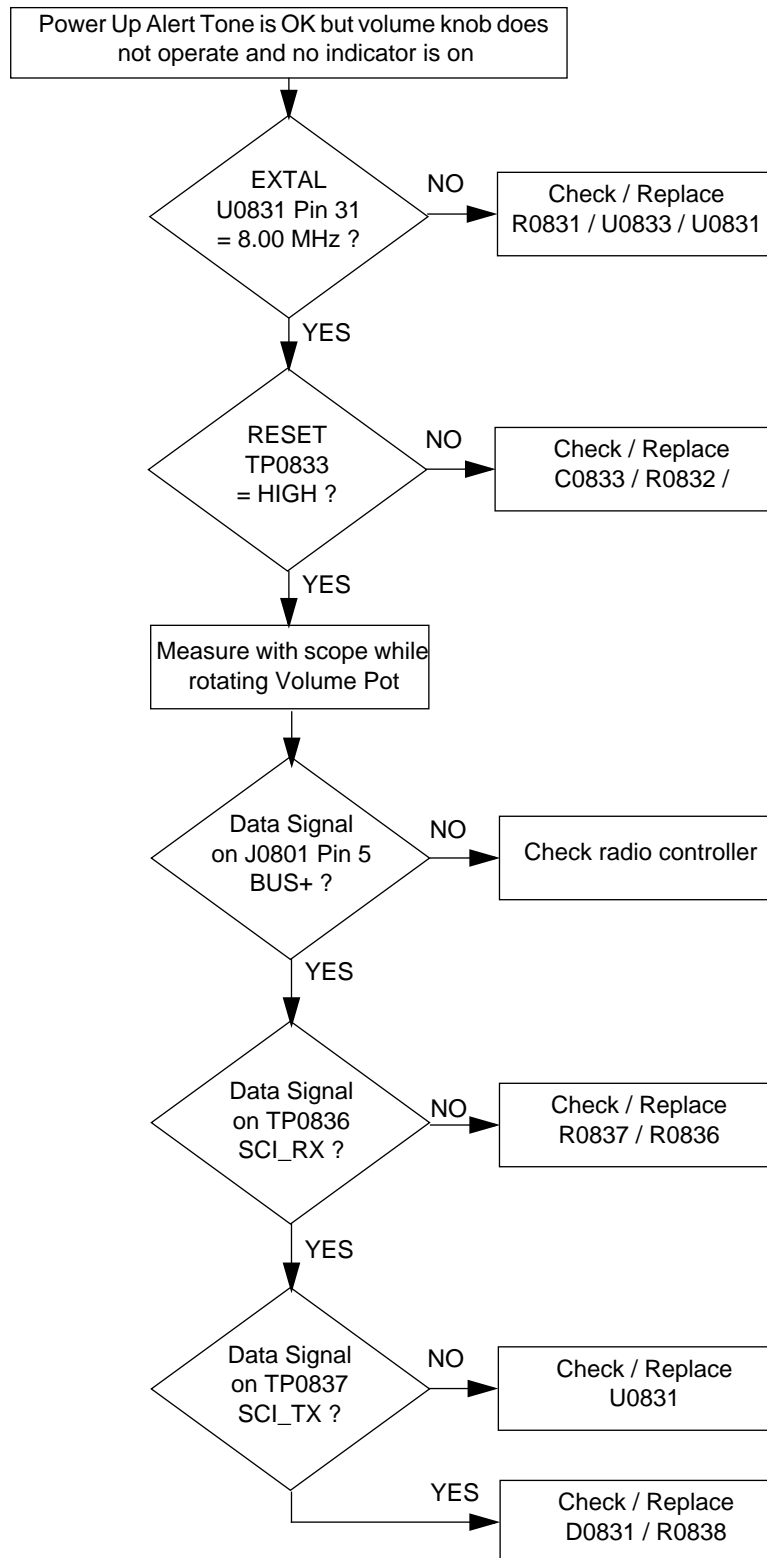

2.3 Display

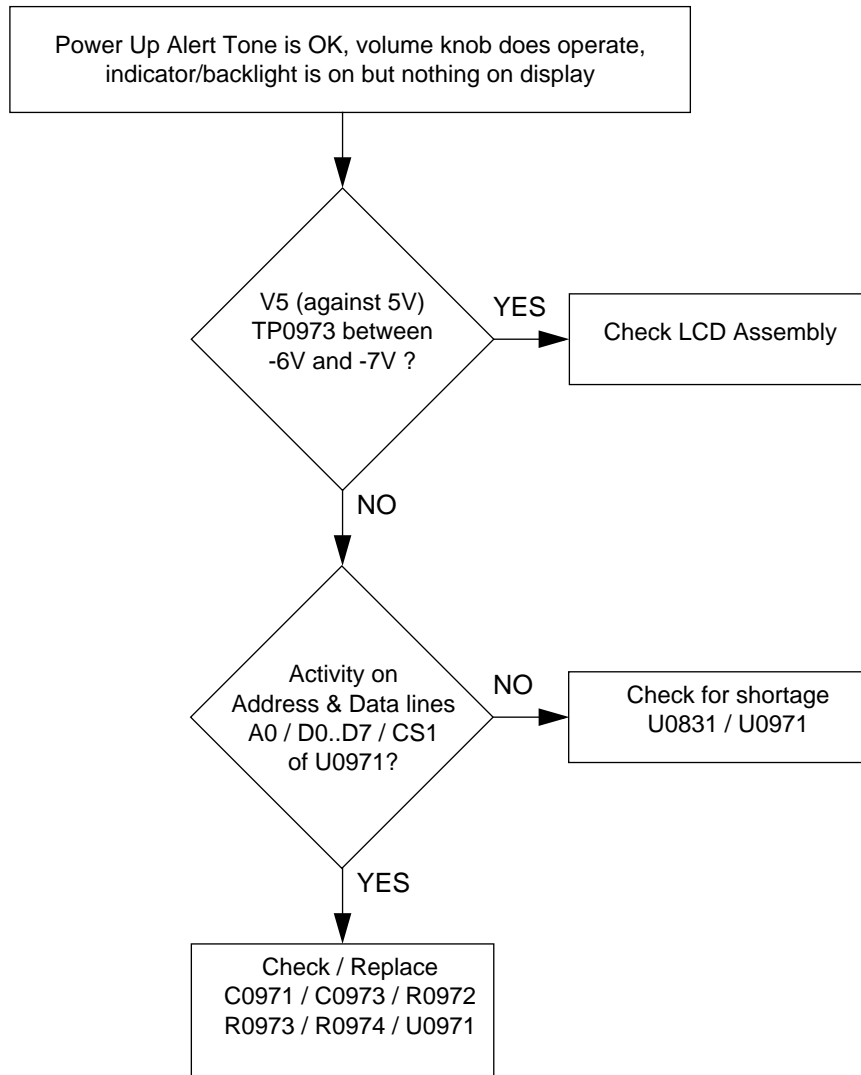

2.4 Backlight

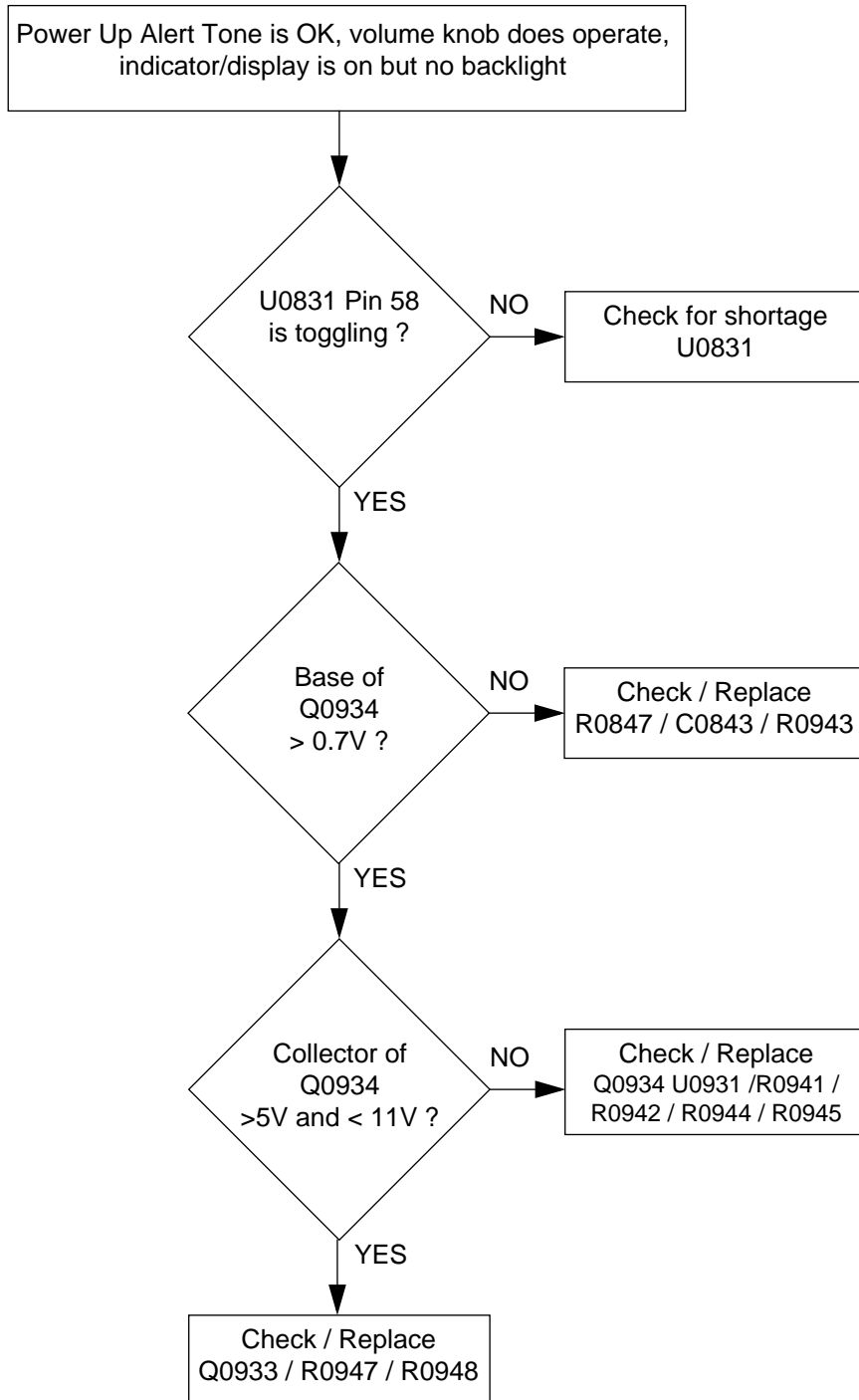

3.0 Controlhead GM380/1280 Troubleshooting Flow Chart

3.1 On/Off

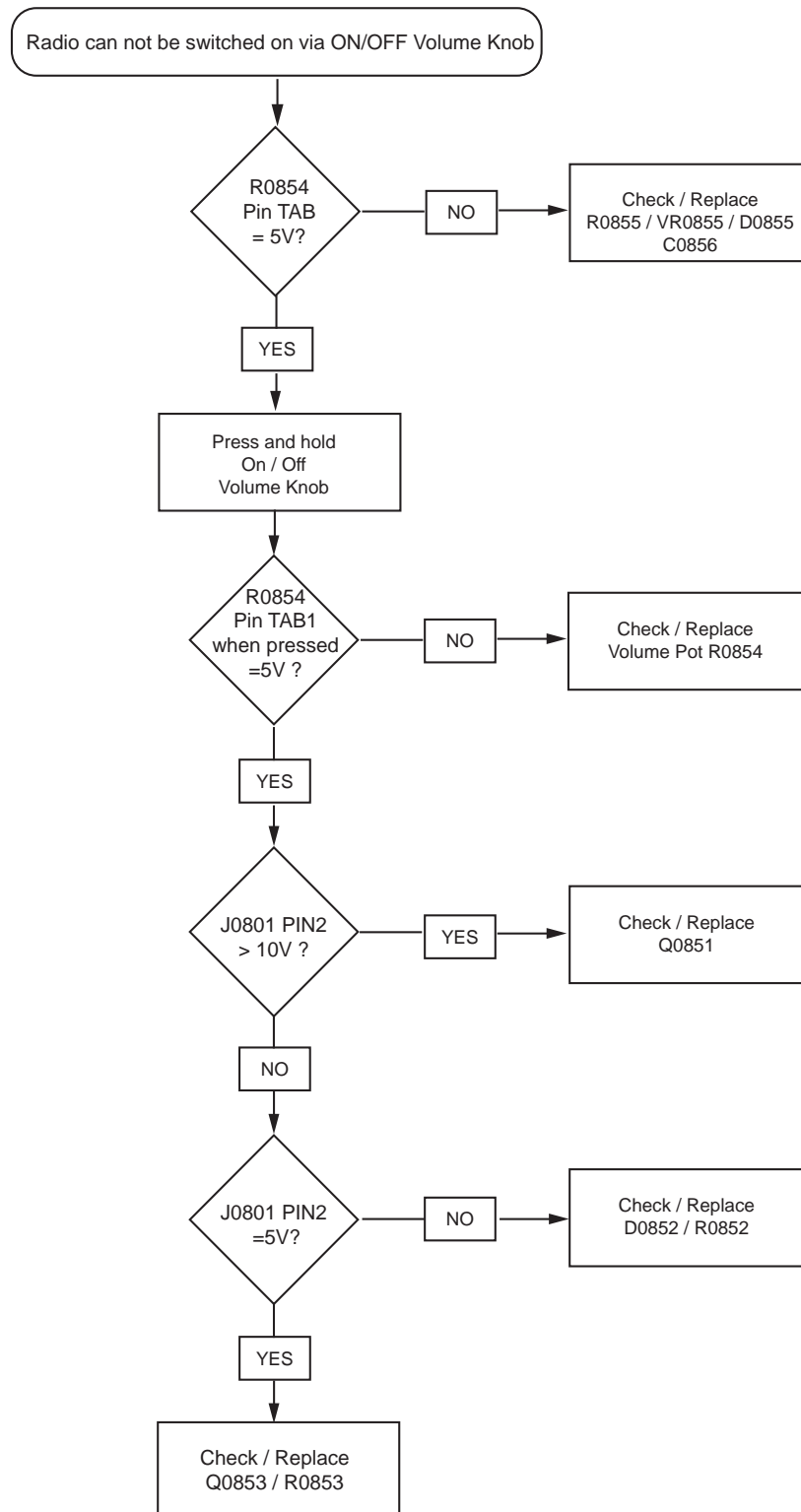

3.2 Microprocessor

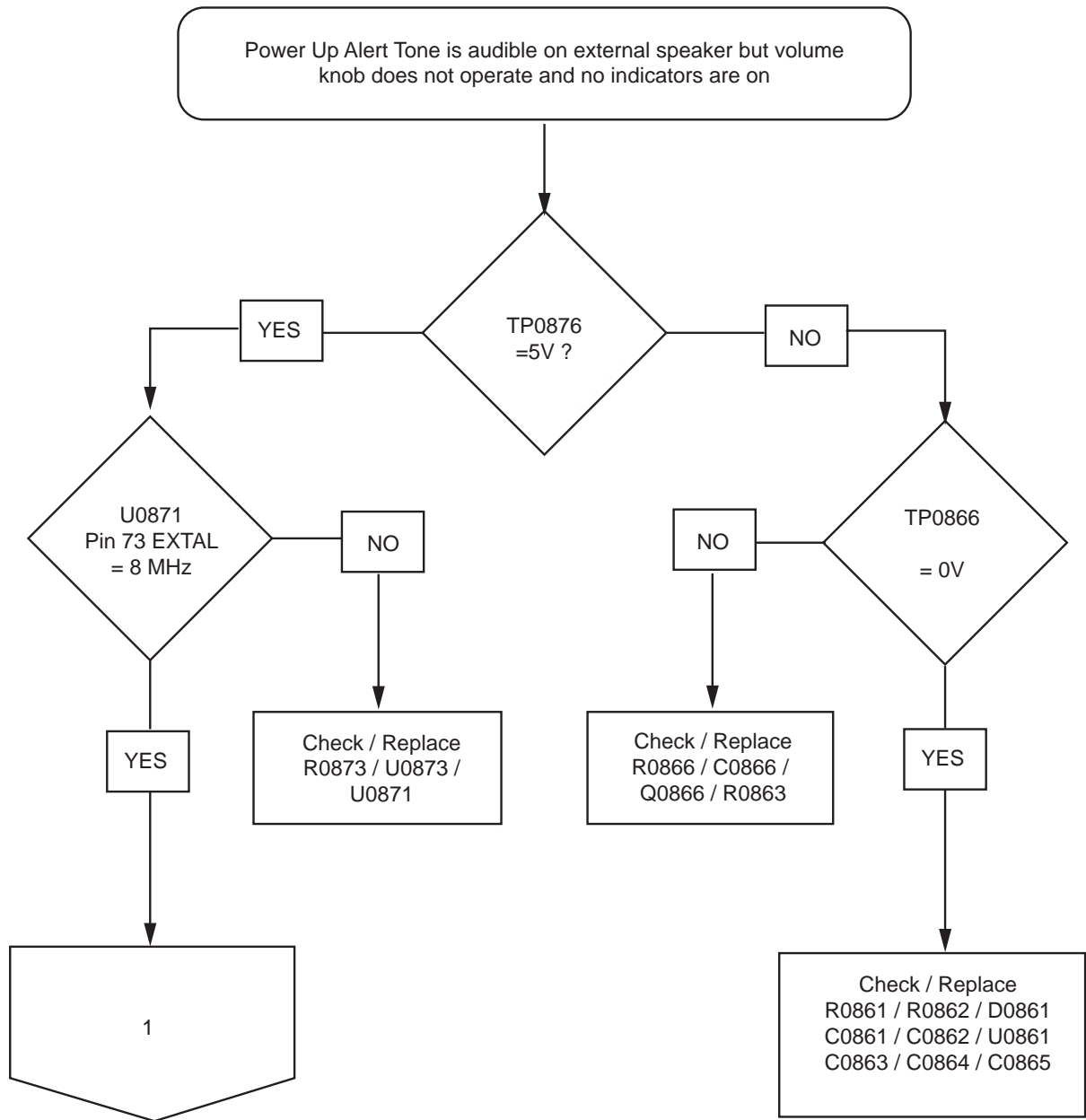

3.3 Microprocessor

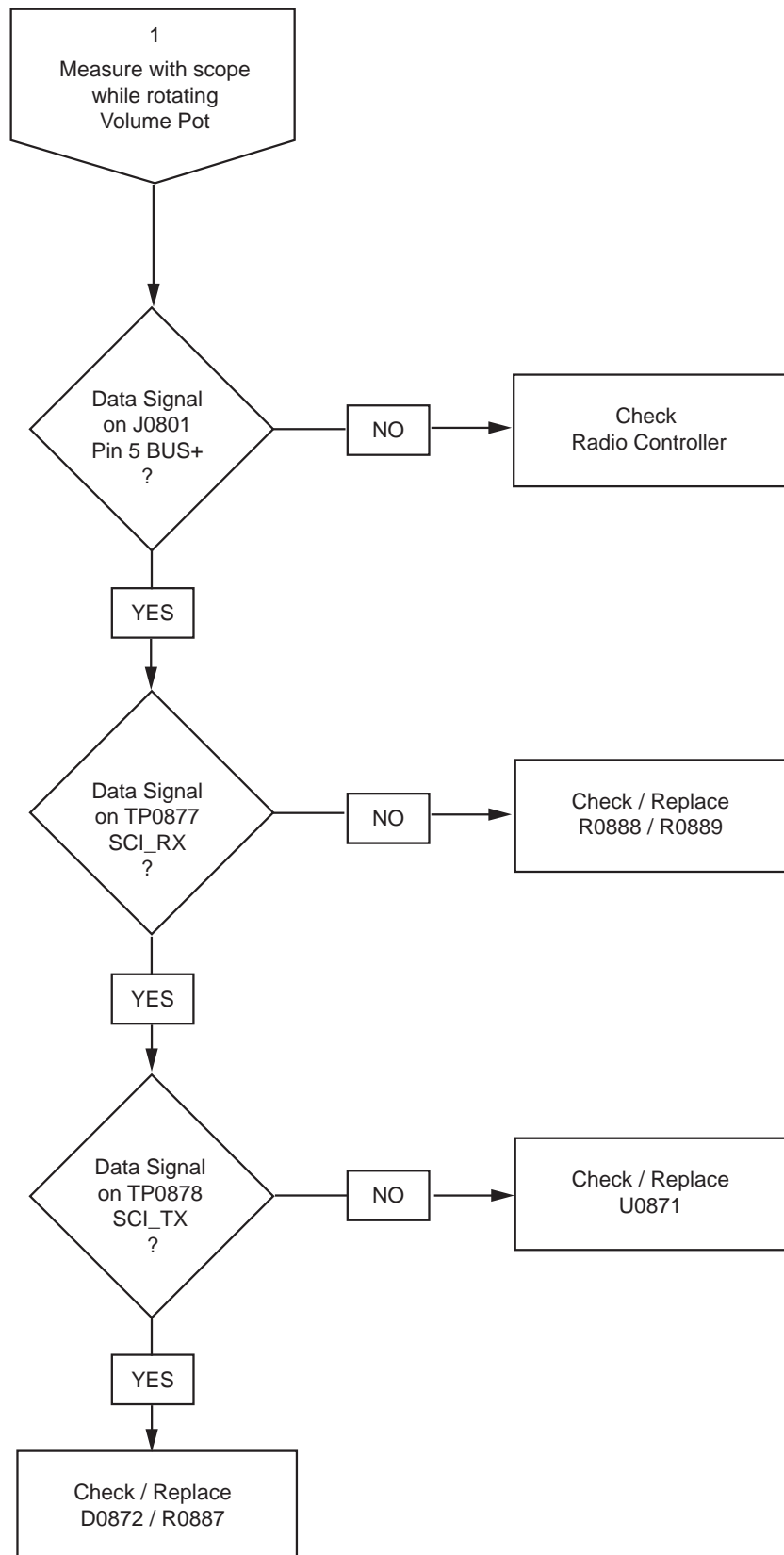

3.4 Display

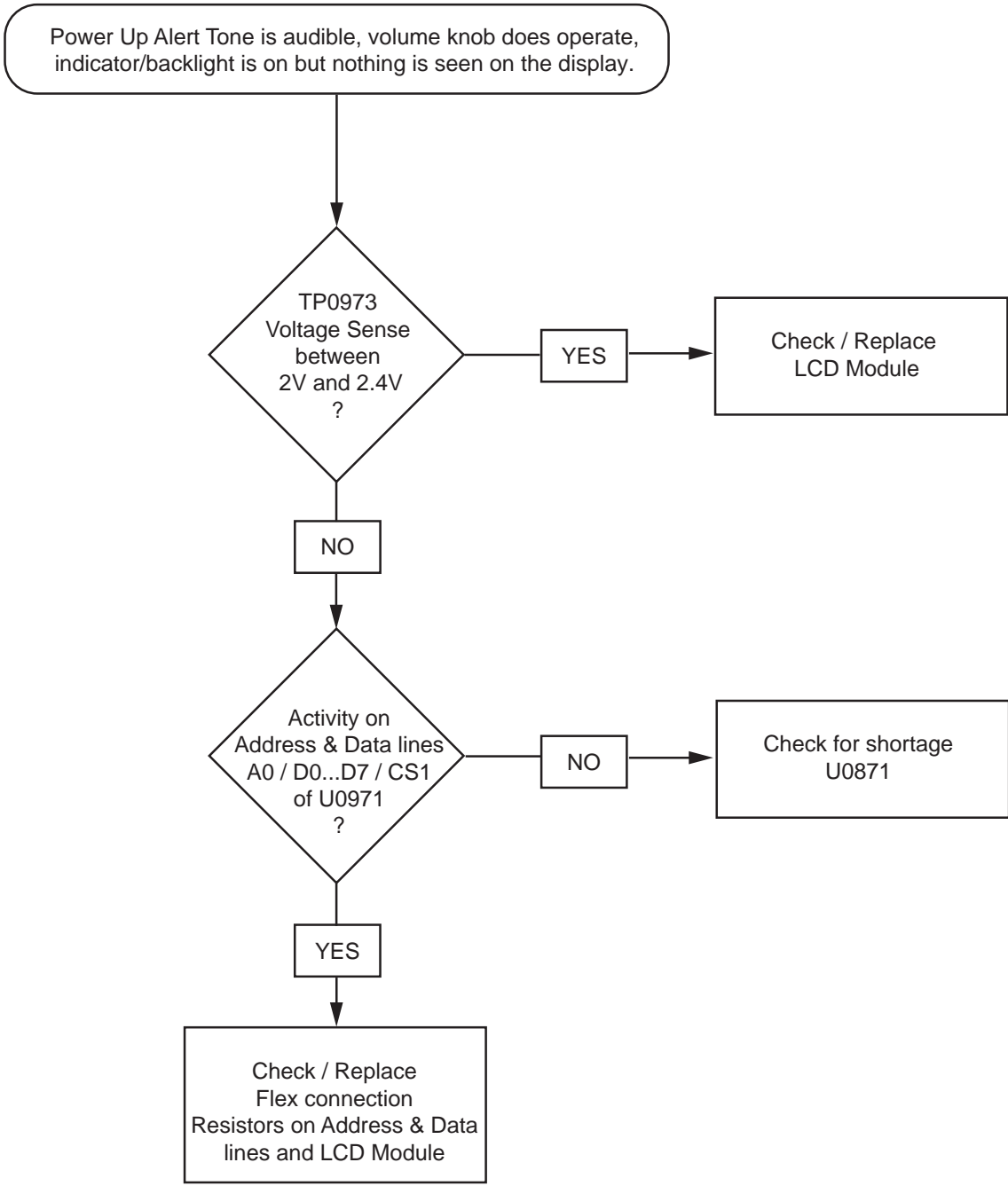

3.5 Keypad Backlight

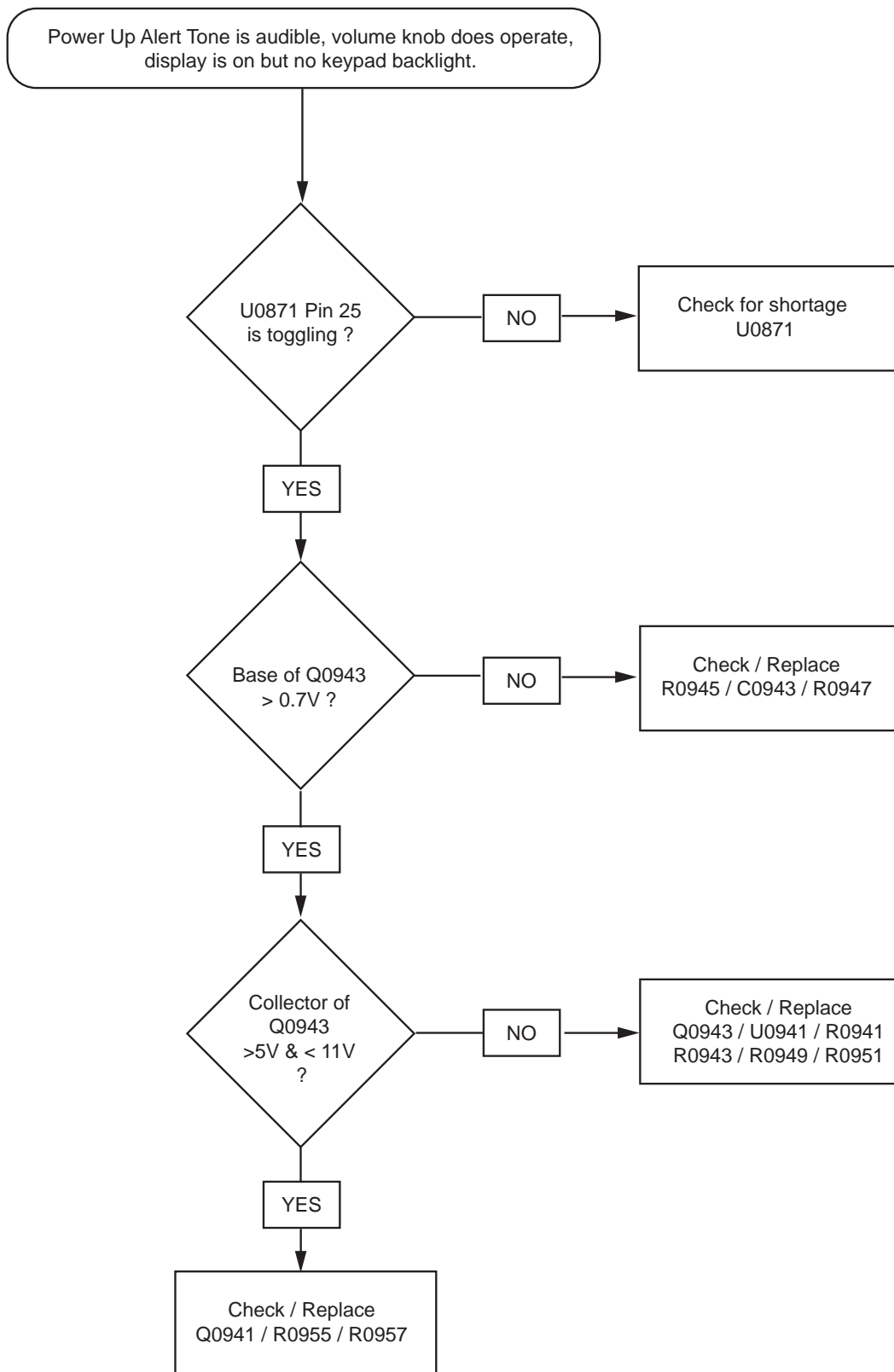

3.6 Display Backlight

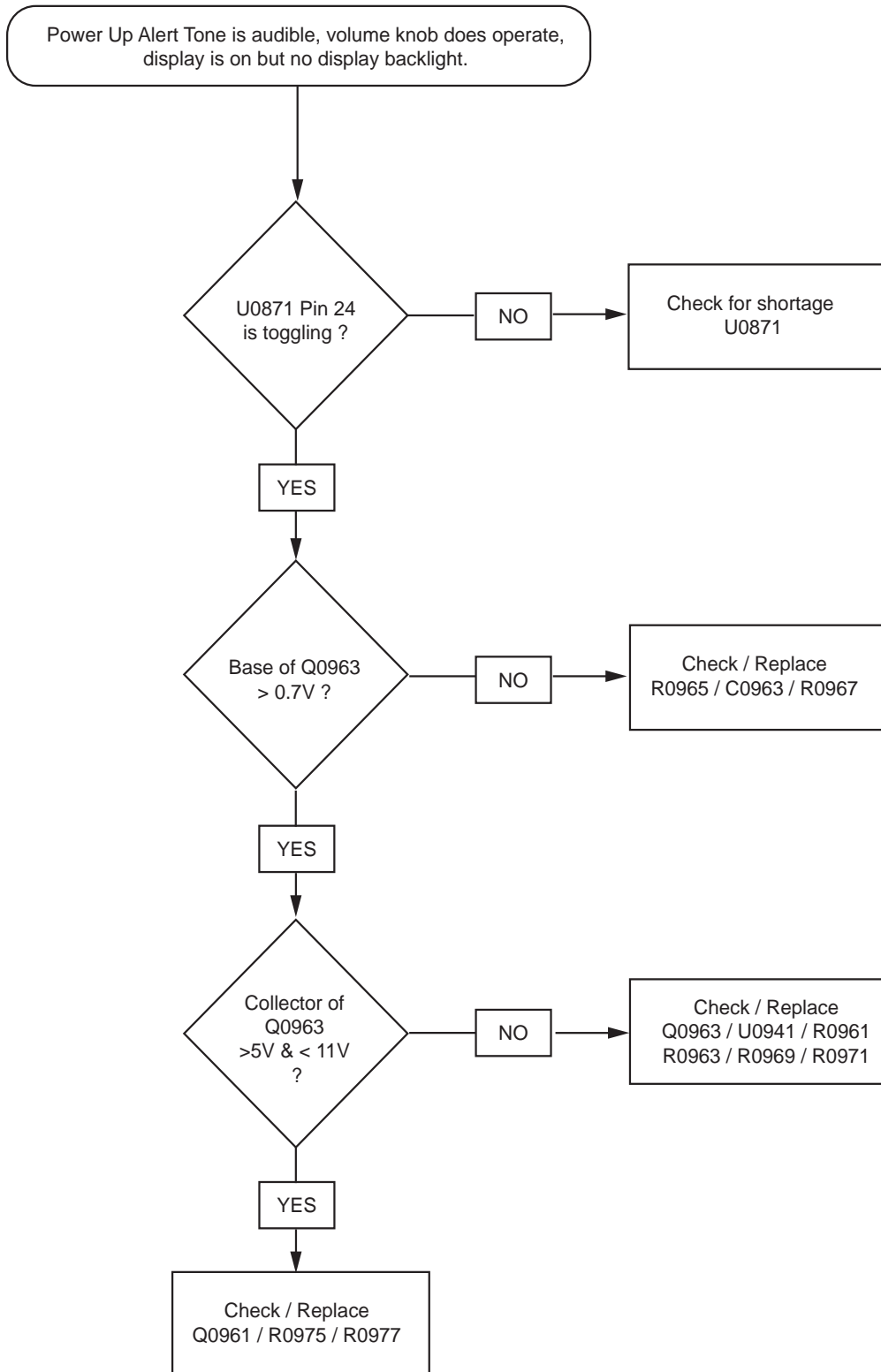

CONTROLHEAD PCB / SCHEMATICS / PARTS LISTS

1.0 Allocation of Schematics and Circuit Boards

Table 4-1 Controlhead Diagrams and Parts Lists

PCB : Controlhead GM140/340/640 8486146B07 Main Board Top Side 8486146B07 Main Board Bottom Side	Page 4-3 Page 4-3
SCHEMATICS Sheet 1 of 2 Sheet 2 of 2	Page 4-4 Page 4-5
Parts List 8486146B07	Page 4-6

Table 4-2 Controlhead Diagrams and Parts Lists

PCB : Controlhead GM160/360/660 8486155B06 Main Board Top Side 8486155B06 Main Board Bottom Side	Page 4-7 Page 4-7
SCHEMATICS Sheet 1 of 4 Sheet 2 of 4 Sheet 3 of 4 Sheet 4 of 4	Page 4-8 Page 4-9 Page 4-10 Page 4-11
Parts List 8486155B06	Page 4-12

Table 4-3 Controlhead Diagrams and Parts Lists

PCB : Controlhead GM380/1280 8486178B03 Main Board Top Side 8486178B03 Main Board Bottom Side	Page 4-13 Page 4-13
SCHEMATICS Sheet 1 of 4 Sheet 2 of 4 Sheet 3 of 4 Sheet 4 of 4	Page 4-14 Page 4-15 Page 4-16 Page 4-17
Parts List 8486178B03	Page 4-18

2.0 Controlhead GM140/340/640 - PCB 8486146B07 / Schematics

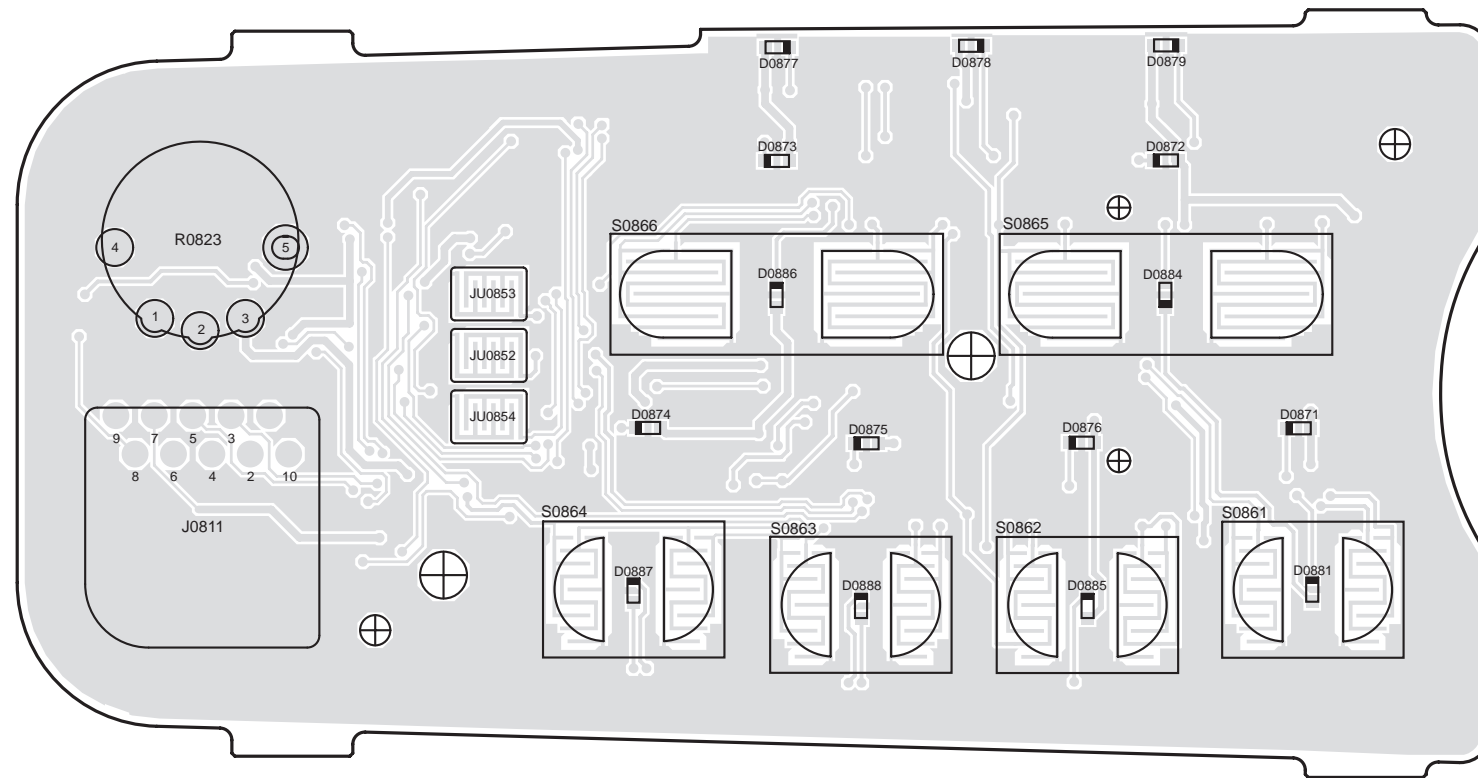

ZWG0130114-A Top Side

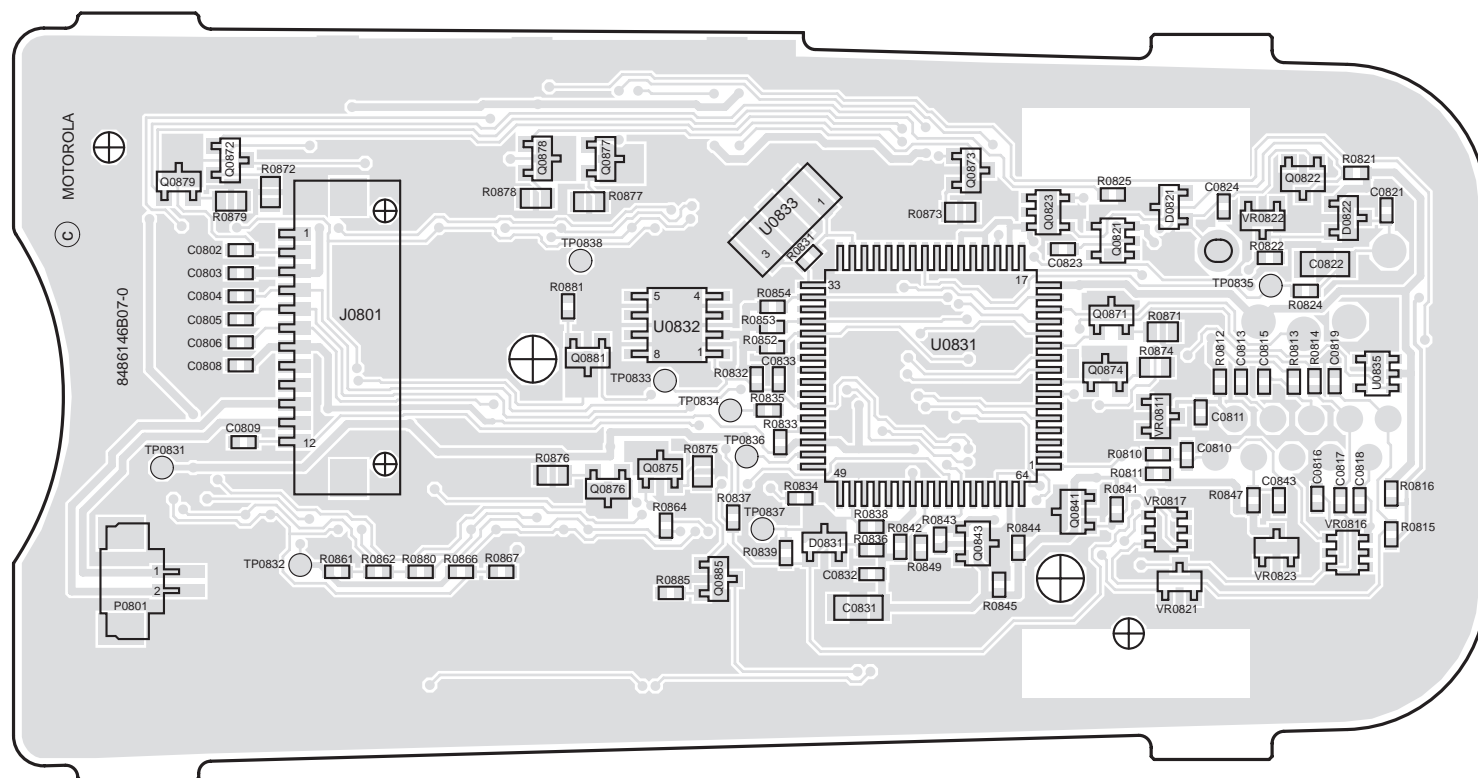

ZWG0130113-B Bottom Side

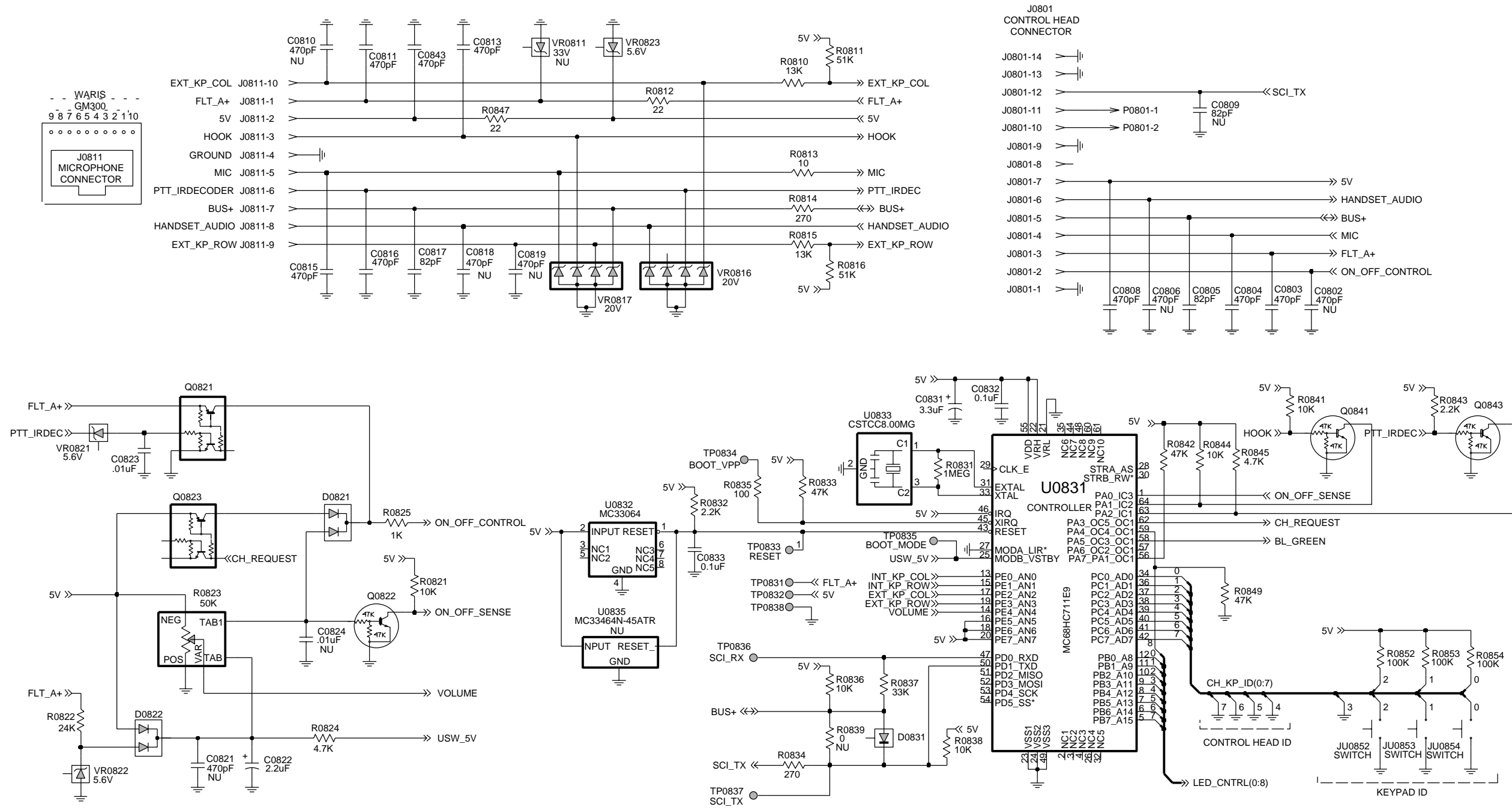

ZWG01300239-A

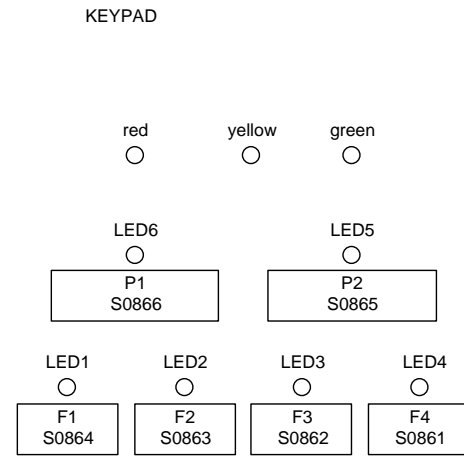

CH_A
sheet 2

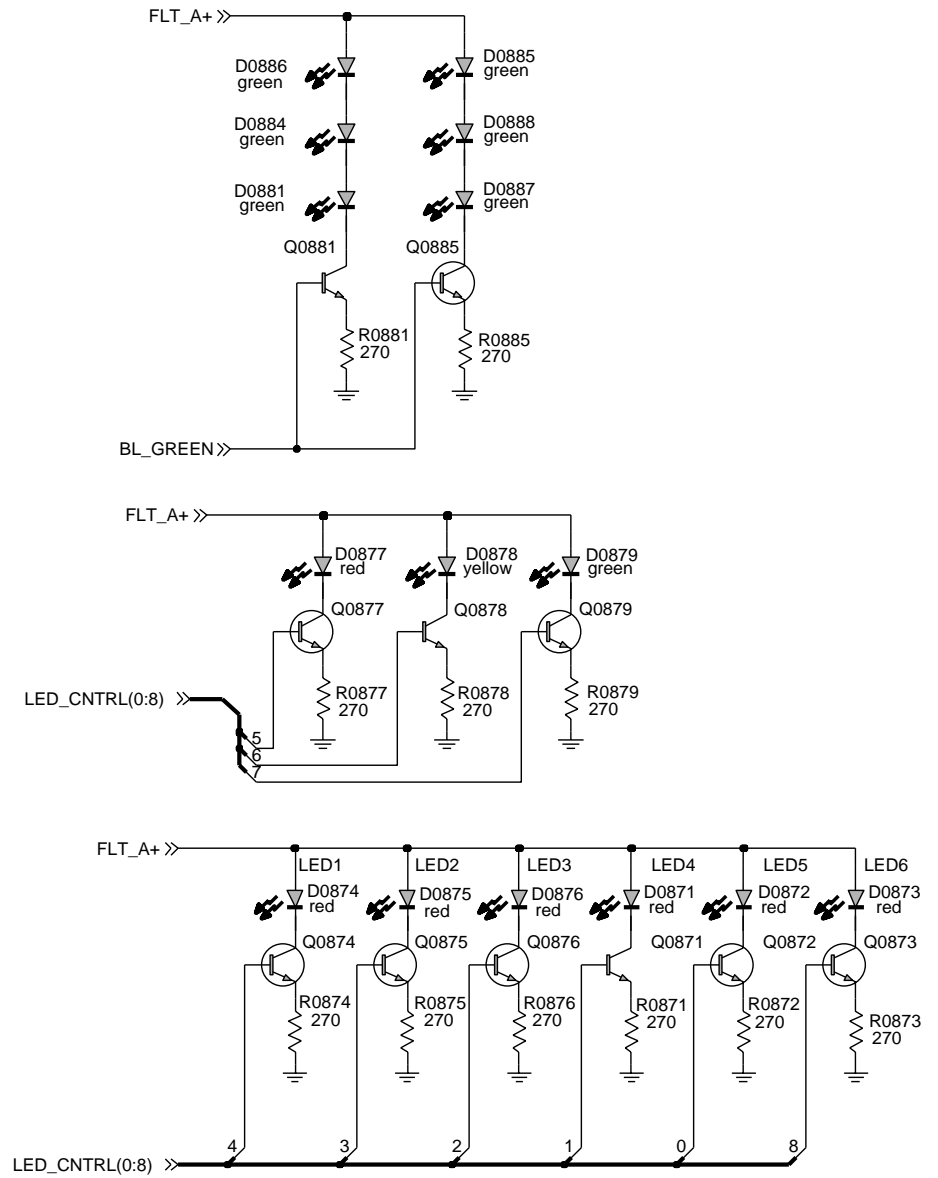
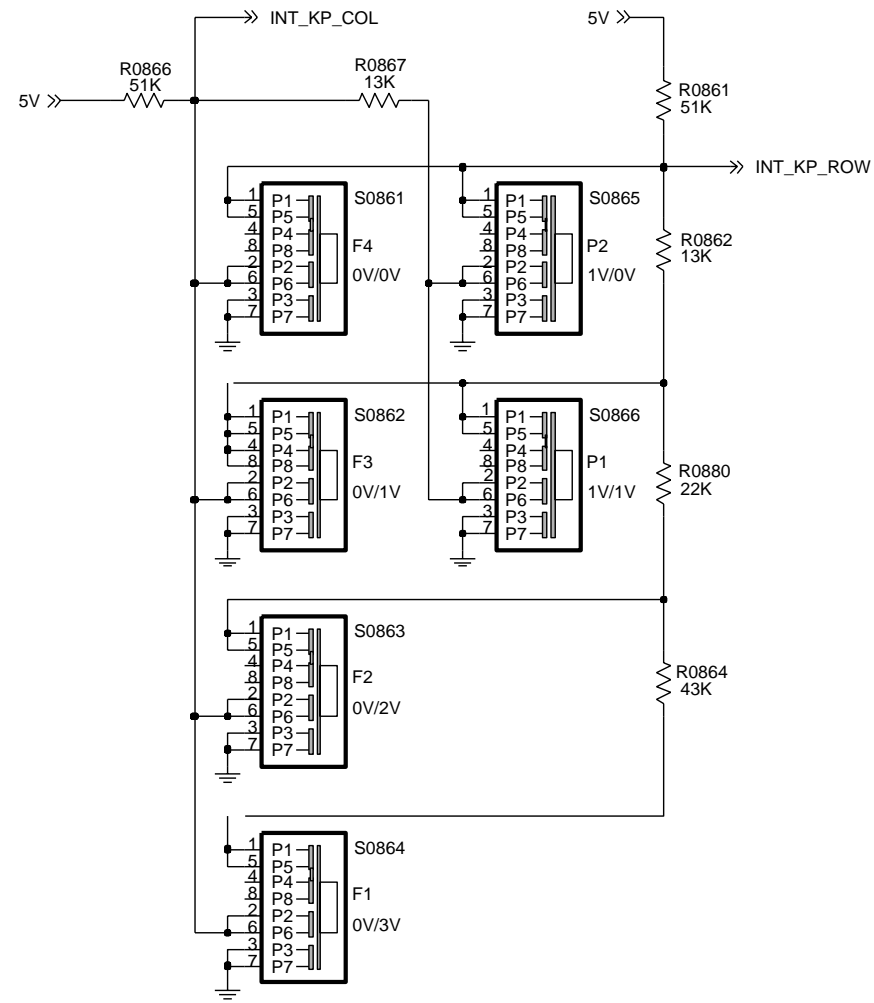

ZWG0130240-A

2.1 Controlhead PCB 8486146B07 Parts List

Circuit Ref	Motorola Part No	Description
C0803	2113741F17	470pF 50V
C0804	2113741F17	470pF 50V
C0805	2113740F49	82pF 5% 50V
C0808	2113741F17	470pF 50V
C0811	2113741F17	470pF 50V
C0813	2113741F17	470pF 50V
C0815	2113741F17	470pF 50V
C0816	2113741F17	470pF 50V
C0817	2113740F49	82pF 5% 50V
C0822	2311049A40	TANT CP 2.2uF 10% 10V
C0823	2113741F49	10nF 50V
C0831	2311049A42	TANT CP 3.3uF 10% 6V
C0832	2113743E20	100nF 16V
C0833	2113743E20	100nF 16V
C0843	2113741F17	470pF 50V
D0821	4813833C02	DUAL SOT MMBD6100
D0822	4813833C02	DUAL SOT MMBD6100
D0831	4880236E05	DIODE CHIP SCHOTTKY
D0871	4886171B01	LED RED
D0872	4886171B01	LED RED
D0873	4886171B01	LED RED
D0874	4886171B01	LED RED
D0875	4886171B01	LED RED
D0876	4886171B01	LED RED
D0877	4886171B01	LED RED
D0878	4886171B03	LED YELLOW
D0879	4886171B04	LED GREEN
D0881	4886171B04	LED GREEN
D0884	4886171B04	LED GREEN
D0885	4886171B04	LED GREEN
D0886	4886171B04	LED GREEN
D0887	4886171B04	LED GREEN
D0888	4886171B04	LED GREEN
J0801	0902636Y02	CONNECTOR FLEX 12 PIN
J0811	2864287B01	CONN TELCO 10 PIN JACK
P0801	2809926G01	CONN 1.25MM 2PIN SURMT
Q0821	4805921T02	TSTR DUAL ROHM FMC2 RH
Q0822	4880048M01	TSTR NPN DIG 47k/47k
Q0823	4805921T02	TSTR DUAL ROHM FMC2 RH
Q0841	4880048M01	TSTR NPN DIG 47k/47k
Q0843	4880048M01	TSTR NPN DIG 47k/47k
Q0871	4813824A10	TSTR NPN 40V .2A B=50-150
Q0872	4813824A10	TSTR NPN 40V .2A B=50-150
Q0873	4813824A10	TSTR NPN 40V .2A B=50-150
Q0874	4813824A10	TSTR NPN 40V .2A B=50-150
Q0875	4813824A10	TSTR NPN 40V .2A B=50-150
Q0876	4813824A10	TSTR NPN 40V .2A B=50-150

Circuit Ref	Motorola Part No	Description
Q0877	4813824A10	TSTR NPN 40V .2A B=50-150
Q0878	4813824A10	TSTR NPN 40V .2A B=50-150
Q0879	4813824A10	TSTR NPN 40V .2A B=50-150
Q0881	4813824A10	TSTR NPN 40V .2A B=50-150
Q0885	4813824A10	TSTR NPN 40V .2A B=50-150
R0810	0662057A76	13k 1/16W 5%
R0811	0662057A90	51k 1/16W 5%
R0812	0662057A09	22 1/16W 5%
R0813	0662057A01	10 1/16W 5%
R0814	0662057A35	270 1/16W 5%
R0815	0662057A76	13k 1/16W 5%
R0816	0662057A90	51k 1/16W 5%
R0821	0662057A73	10k 1/16W 5%
R0822	0662057A82	24K 1/16W 5%
R0823	1805911V02	POT VOL
R0824	0662057A65	4k7 1/16W 5%
R0825	0662057A49	1k 1/16W 5%
R0831	0662057B22	1M 1/16W 5%
R0832	0662057A57	2k2 1/16W 5%
R0833	0662057A89	47k 1/16W 5%
R0834	0662057A35	270 1/16W 5%
R0835	0662057A25	100 1/16W 5%
R0836	0662057A73	10k 1/16W 5%
R0837	0662057A85	33k 1/16W 5%
R0838	0662057A73	10k 1/16W 5%
R0841	0662057A73	10k 1/16W 5%
R0842	0662057A89	47k 1/16W 5%
R0843	0662057A57	2.2k 1/16W 5%
R0844	0662057A73	10k 1/16W 5%
R0845	0662057A65	4k7 1/16W 5%
R0847	0662057A09	22 1/16W 5%
R0849	0662057A89	47k 1/16W 5%
R0852	0662057A97	100k 1/16W
R0853	0662057A97	100k 1/16W
R0854	0662057A97	100k 1/16W
R0861	0662057A90	51k 1/16W 5%
R0862	0662057A76	13k 1/16W 5%
R0864	0662057A88	43k 1/16W 5%
R0866	0662057A90	51k 1/16W 5%
R0867	0662057A76	13k 1/16W 5%
R0871	0660076A35	270 5 1/8
R0872	0660076A35	270 5 1/8
R0873	0660076A35	270 5 1/8
R0874	0660076A35	270 5 1/8
R0875	0660076A35	270 5 1/8
R0876	0660076A35	270 5 1/8
R0877	0660076A35	270 5 1/8
R0878	0660076A35	270 5 1/8
R0879	0660076A35	270 5 1/8
R0880	0662057A81	22k 1/16W 5%
R0881	0662057A35	270 1/16W 5%

Circuit Ref	Motorola Part No	Description
R0885	0662057A35	270 1/16W 5%
*U0831	5113802A24	IC 68HC11 W/SCI,SPI,A/D
U0833	4886061B01	CER RESONATOR 8MHZ CSTCC8.00MG
VR0816	4805656W09	DIODE ZENER QUAD MMQA20VT1
VR0817	4805656W09	DIODE ZENER QUAD MMQA20VT1
VR0821	4813830A15	DIODE 5.6V 5% 225mW
VR0822	4813830A15	DIODE 5.6V 5% 225mW
VR0823	4813830A15	DIODE 5.6V 5% 225mW

* Motorola Depot Servicing only

Reference designators with an asterisk indicate components which are not fieldreplaceable because they need to be calibrated with specialized factory equipment after installation. Radios in which these parts have been replaced in the field will be off frequency at temperature extremes.

3.0 Controlhead GM160/360/660 - PCB 8486155B06 / Schematics

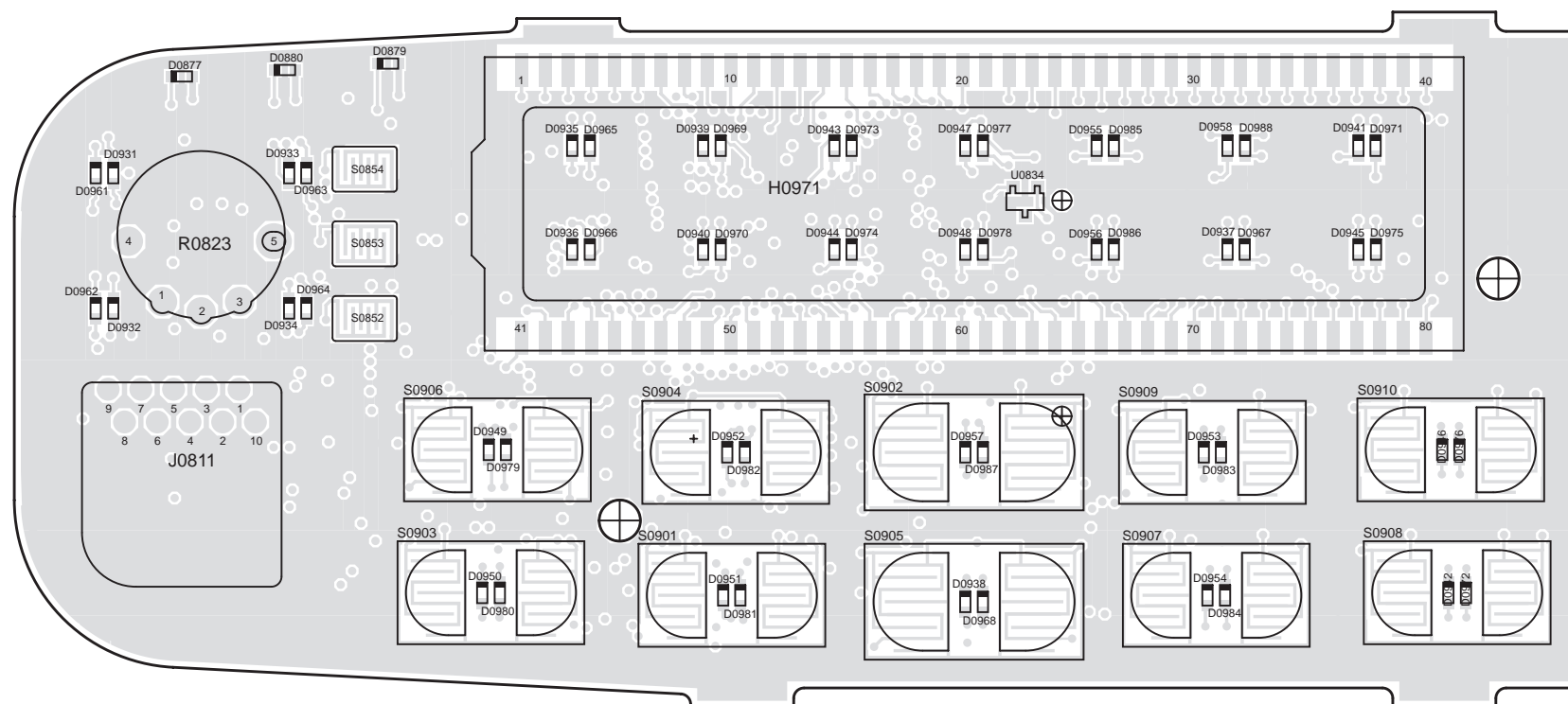

ZWG0130136-A Top Side

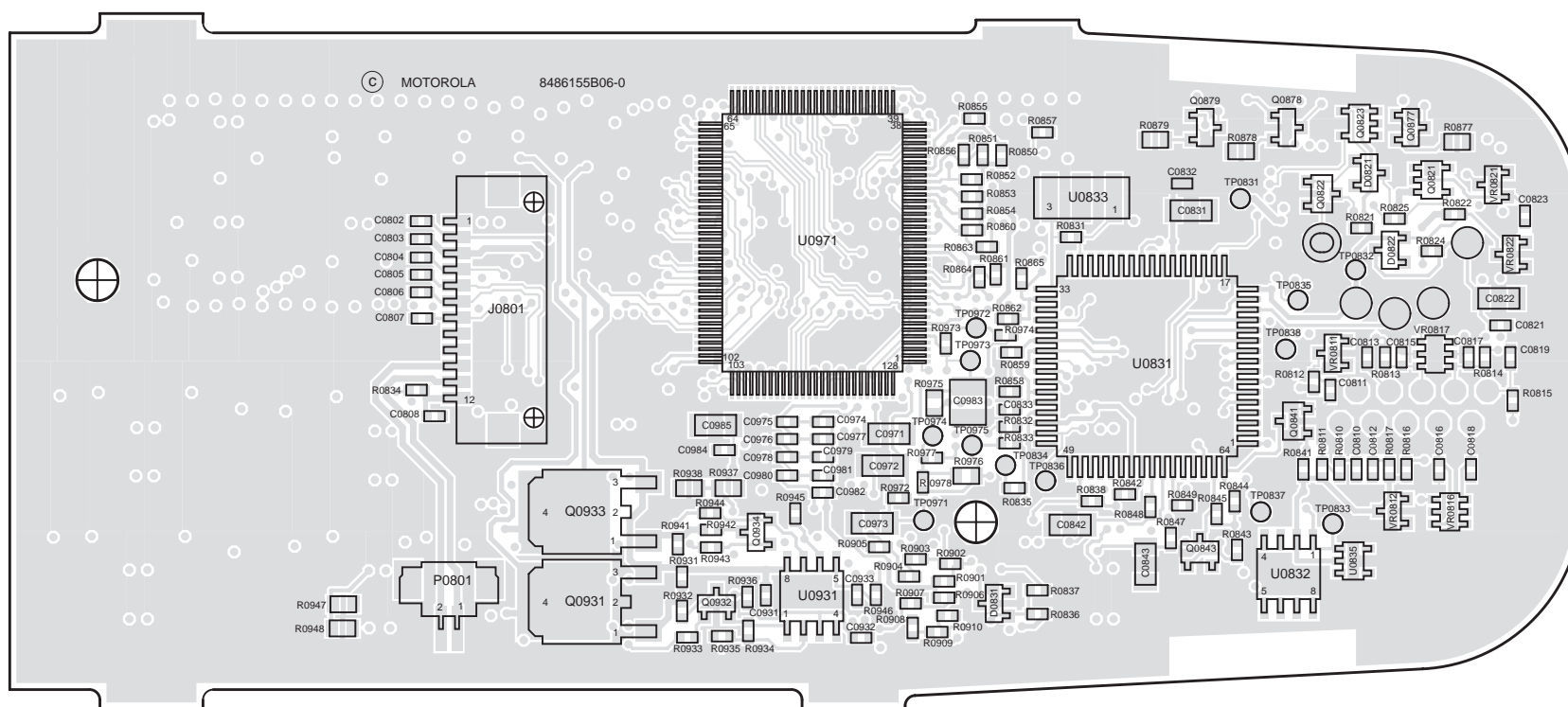

ZWG0130137-B Bottom Side

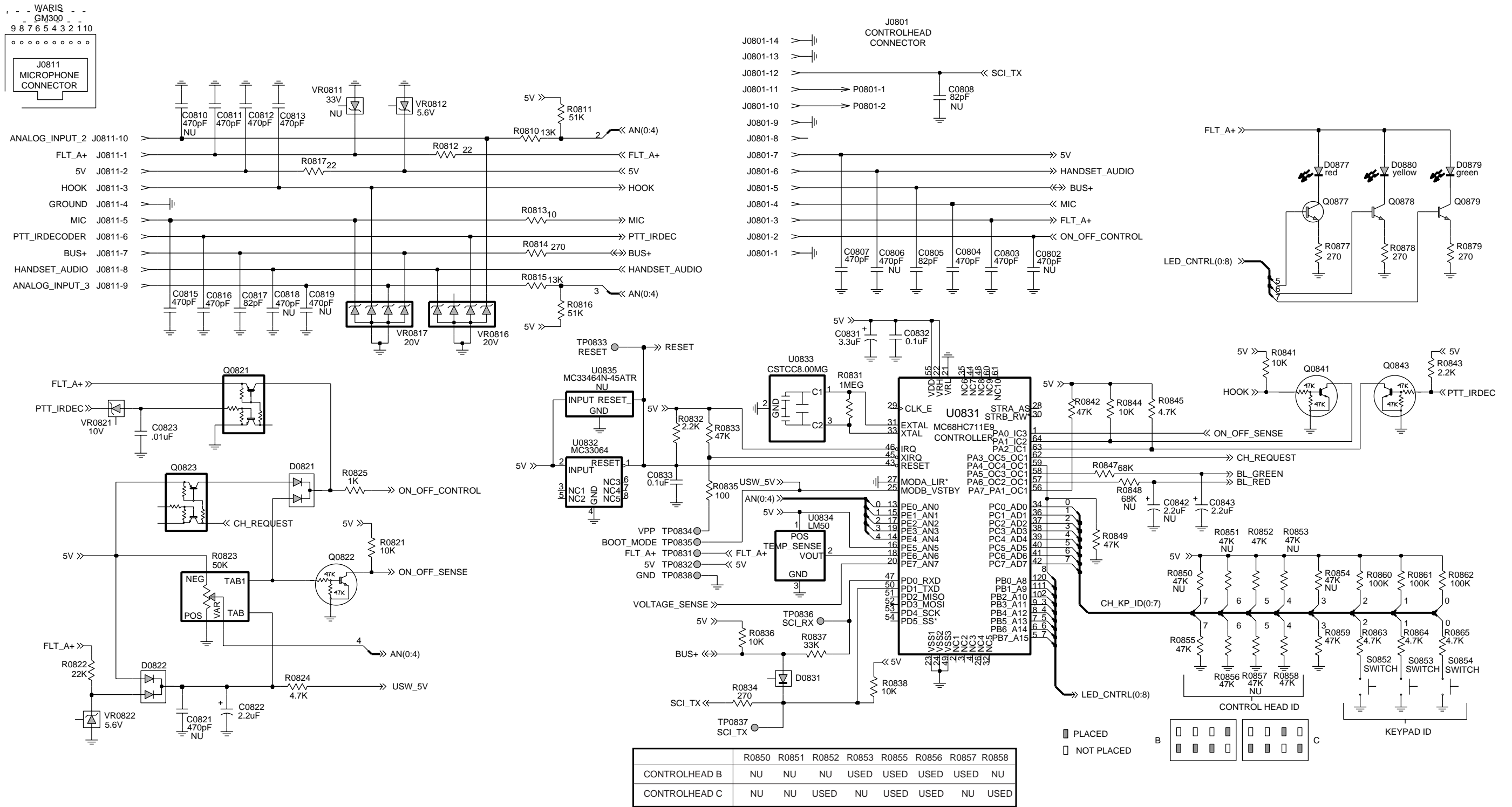

ZWG0130241-A

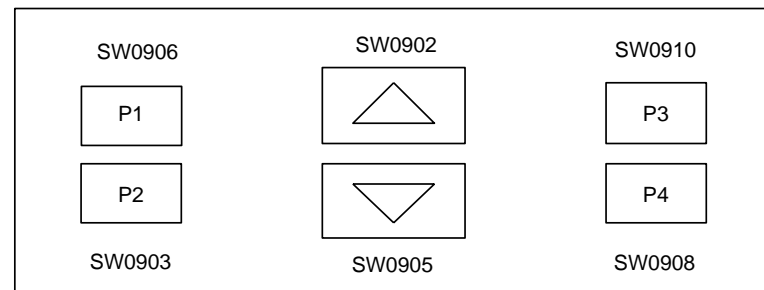

KEYPAD C

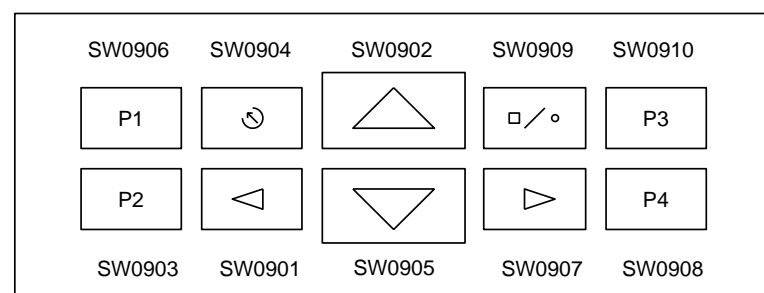

CH_B
CH_C
sheet 2

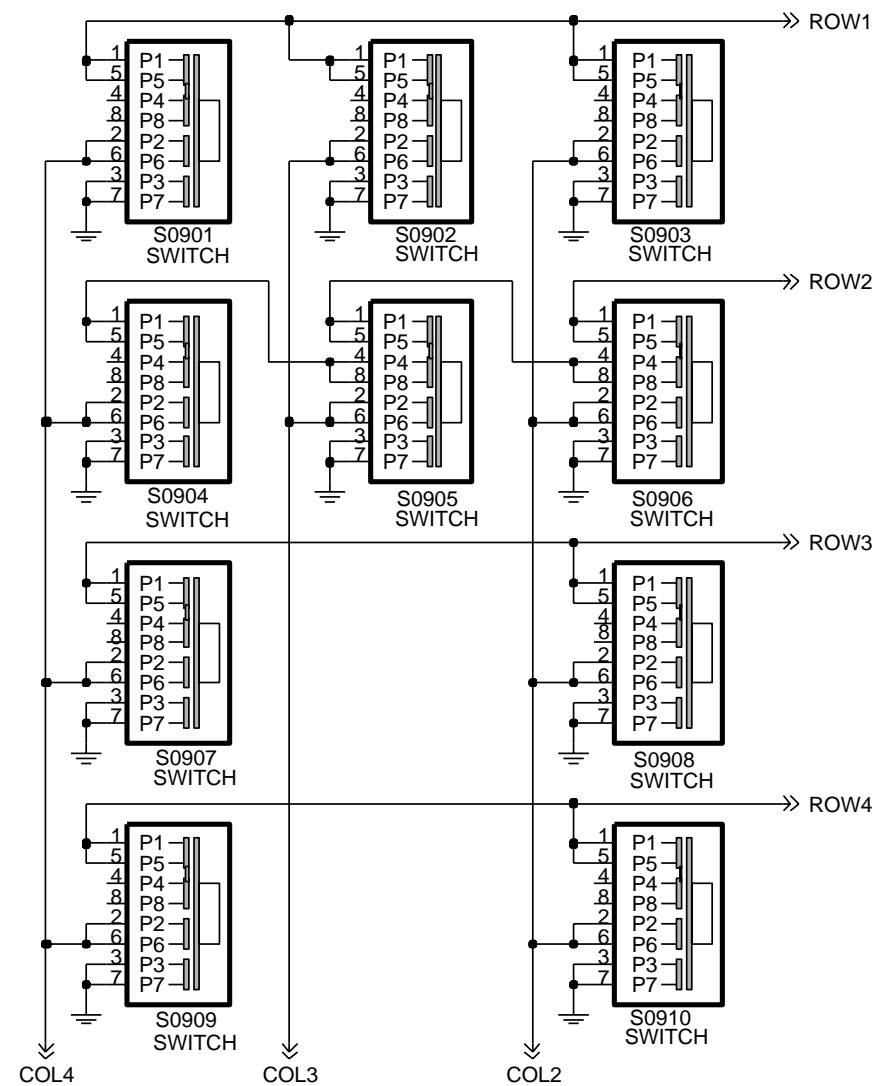
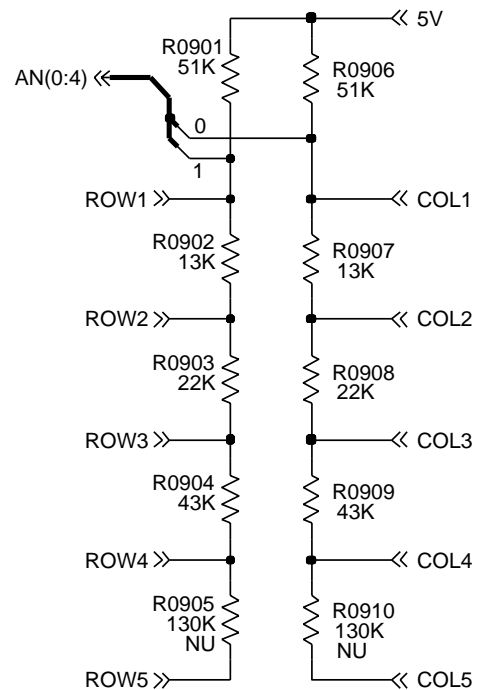

ZWG0130242-A

BACKLIGHT GREEN

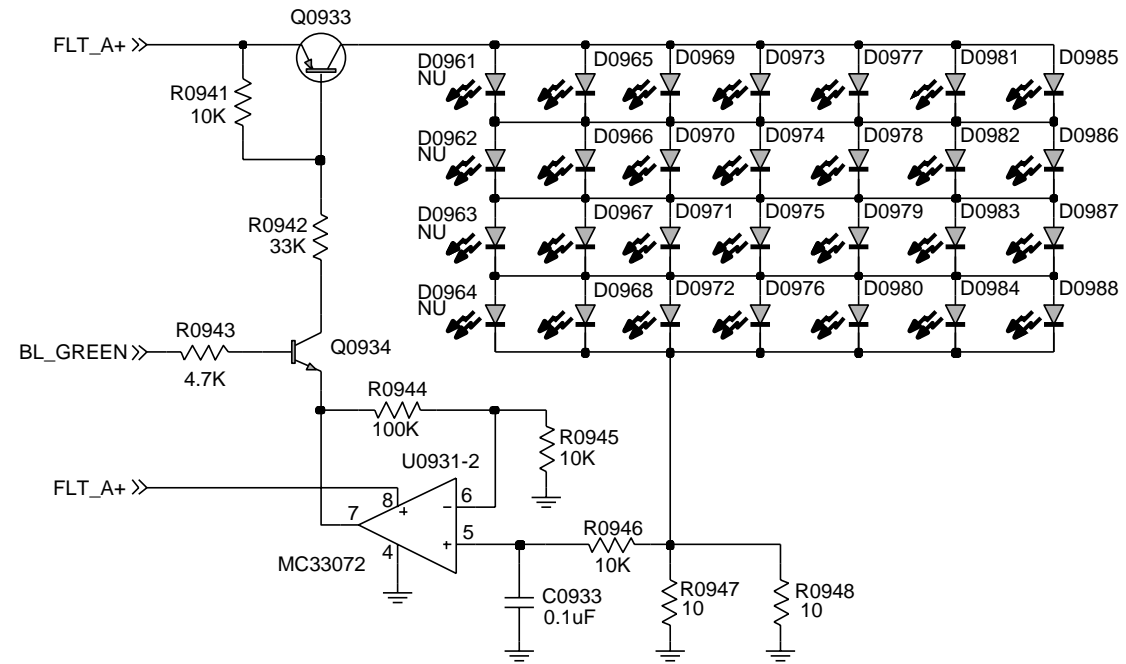

BACKLIGHT RED

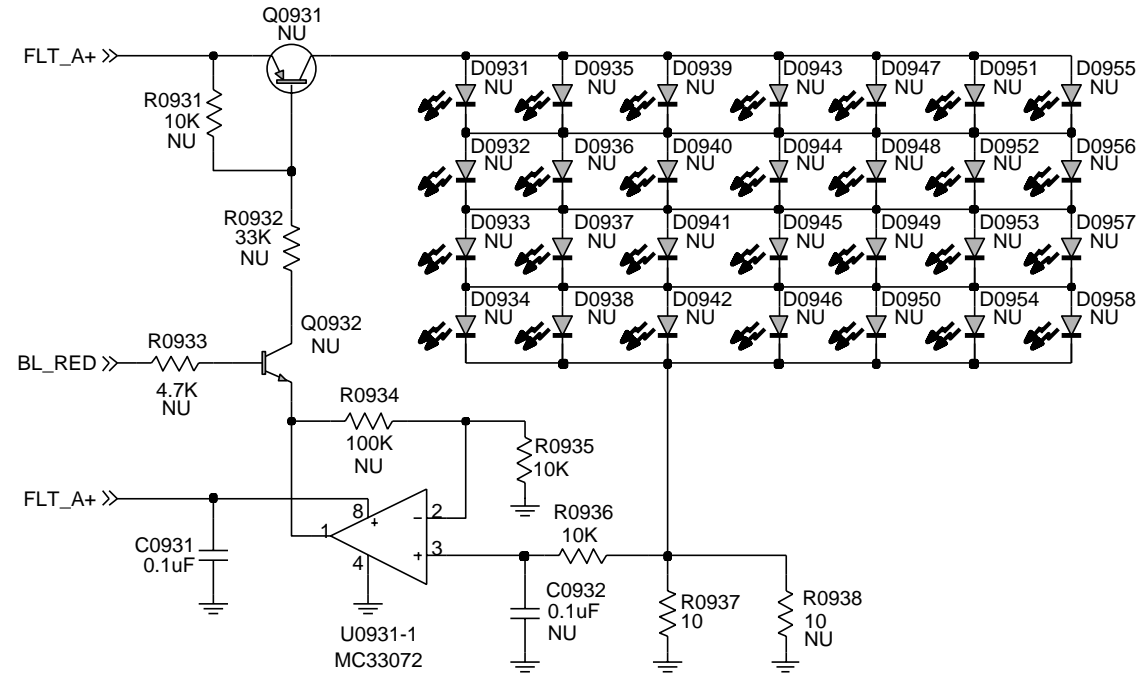

ZWG0130243-A

THE LCD IS PART OF HARDWAREKITS GLN7358A (EUR) AND GLN7359A (US)

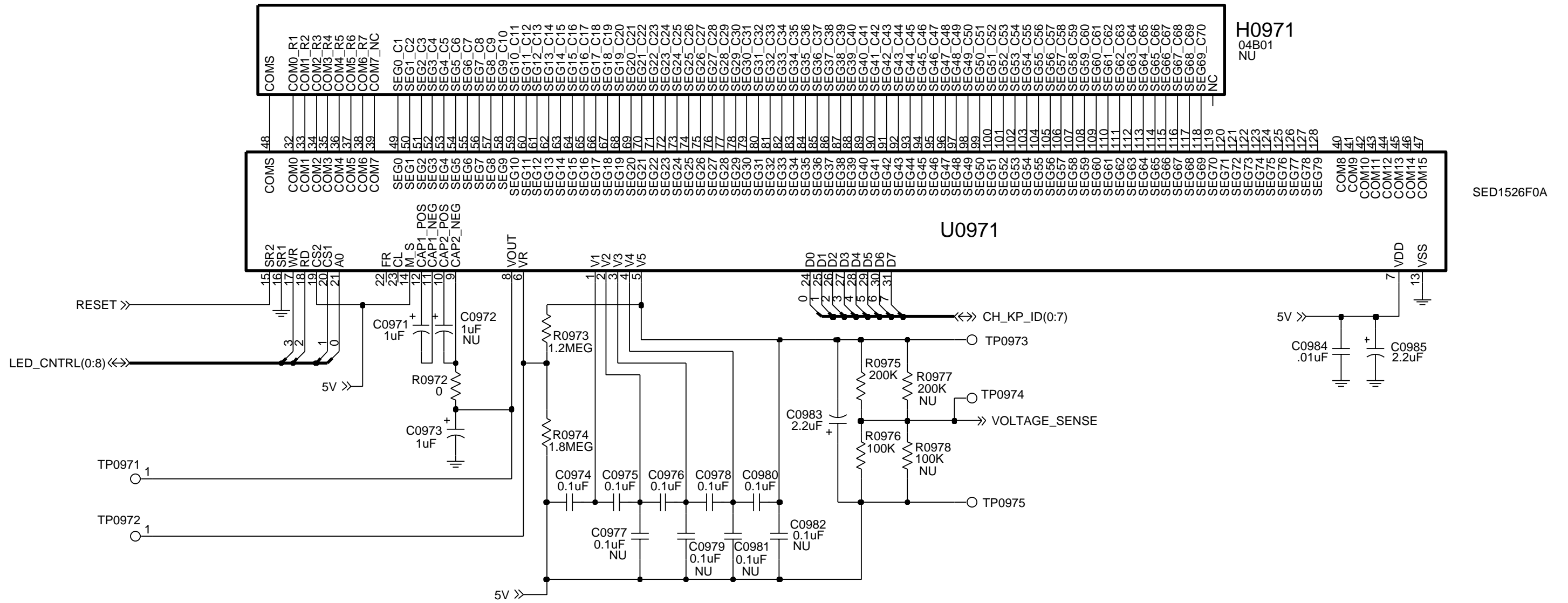

ZWG0130244-A

3.1 Controlhead PCB 8486155B06 Parts List

Circuit Ref	Motorola Part No	Description
C0803	2113741F17	470pF 50V
C0804	2113741F17	470pF 50V
C0805	2113740F49	82pF 5% 50V NPO
C0807	2113741F17	470pF 50V
C0811	2113741F17	470pF 50V
C0812	2113741F17	470pF 50V
C0813	2113741F17	470pF 50V
C0815	2113741F17	470pF 50V
C0816	2113741F17	470pF 50V
C0817	2113740F49	82pF 5% 50V
C0822	2311049A40	TANT CP 2.2uF 10% 10V
C0823	2113741F49	10nF 50V
C0831	2311049A42	TANT CP 3.3uF 10% 6V
C0832	2113743E20	100nF 16V
C0843	2311049A40	TANT CP 2.2uF 10% 10V
C0931	2113743E20	100nF 16V
C0933	2113743E20	100nF 16V
C0971	2311049A07	TANT CP 1uF 10% 16V
C0973	2311049A07	TANT CP 1uF 10% 16V
C0974	2113743E20	100nF 16V
C0975	2113743E20	100nF 16V
C0976	2113743E20	100nF 16V
C0978	2113743E20	100nF 16V
C0980	2113743E20	100nF 16V
C0983	2311049A09	TANT CP 2.2uF 10% 20V
C0984	2113741F49	10nF 50V
C0985	2311049A40	TANT CP 2.2uF 10% 10V
D0821	4813833C02	DIODE DUAL SOT MMBD6100
D0822	4813833C02	DIODE DUAL SOT MMBD6100
D0831	4880236E05	DIODE CHIP SCHOTTKY
D0877	4886171B01	LED RED
D0879	4886171B04	LED GREEN
D0880	4886171B03	LED YELLOW
D0951	4886171B02	LED ORANGE Not used in Controlhead B
D0952	4886171B02	LED ORANGE Not used in Controlhead B
D0953	4886171B02	LED ORANGE Not used in Controlhead B
D0954	4886171B02	LED ORANGE Not used in Controlhead B
D0965	4886171B04	LED GREEN
D0966	4886171B04	LED GREEN
D0967	4886171B04	LED GREEN
D0968	4886171B04	LED GREEN

Circuit Ref	Motorola Part No	Description
D0969	4886171B04	LED GREEN
D0970	4886171B04	LED GREEN
D0971	4886171B04	LED GREEN
D0972	4886171B04	LED GREEN
D0973	4886171B04	LED GREEN
D0974	4886171B04	LED GREEN
D0975	4886171B04	LED GREEN
D0976	4886171B04	LED GREEN
D0977	4886171B04	LED GREEN
D0978	4886171B04	LED GREEN
D0979	4886171B04	LED GREEN
D0980	4886171B04	LED GREEN
D0981	4886171B04	LED GREEN Not used in Controlhead B
D0982	4886171B04	LED GREEN Not used in Controlhead B
D0983	4886171B04	LED GREEN Not used in Controlhead B
D0984	4886171B04	LED GREEN Not used in Controlhead B
D0985	4886171B04	LED GREEN
D0986	4886171B04	LED GREEN
D0987	4886171B04	LED GREEN
D0988	4886171B04	LED GREEN
J0801	0902636Y02	CONNECTOR FLEX 12 PIN
J0811	2864287B01	CONN TELCO 10 PIN JACK
P0801	2809926G01	CONN 1.25MM 2PIN SUR MT
Q0821	4805921T02	TSTR DUAL ROHM FMC2 RH
Q0822	4880048M01	TSTR NPN DIG 47k/47k
Q0823	4805921T02	TSTR DUAL ROHM FMC2 RH
Q0841	4880048M01	TSTR NPN DIG 47k/47k
Q0843	4880048M01	TSTR NPN DIG 47k/47k
Q0877	4813824A10	TSTR NPN 40V .2A B=50-150
Q0878	4813824A10	TSTR NPN 40V .2A B=50-150
Q0879	4813824A10	TSTR NPN 40V .2A B=50-150
Q0933	4813822A08	TSTR PNP 25V 5AMJD210T4
Q0934	4813824A10	TSTR NPN 40V .2A B=50-150
R0810	0662057A76	13k 1/16W 5%
R0811	0662057A90	51k 1/16W 5%
R0812	0662057A09	22 1/16W 5%
R0813	0662057A01	10 1/16W 5%
R0814	0662057A35	270 1/16W 5%
R0815	0662057A76	13k 1/16W 5%
R0816	0662057A90	51k 1/16W 5%
R0817	0662057A09	22 1/16W 5%
R0821	0662057A73	10k 1/16W 5%
R0822	0662057A81	22k 1/16W 5%
R0823	1805911V02	POT VOL
R0824	0662057A65	4k7 1/16W 5%
R0825	0662057A49	1k 1/16W 5%
R0831	0662057B22	1M 1/16W 5%

Circuit Ref	Motorola Part No	Description
R0832	0662057A57	2k2 1/16W 5%
R0833	0662057A89	47k 1/16W 5%
R0834	0662057A35	270 1/16W 5%
R0835	0662057A25	100 1/16W 5%
R0836	0662057A73	10k 1/16W 5%
R0837	0662057A85	33k 1/16W 5%
R0838	0662057A73	10k 1/16W 5%
R0841	0662057A73	10k 1/16W 5%
R0842	0662057A89	47k 1/16W 5%
R0843	0662057A57	2.2k 1/16W 5%
R0844	0662057A73	10k 1/16W 5%
R0845	0662057A65	4k7 1/16W 5%
R0847	0662057A93	68k 1/16W 5%
R0849	0662057A89	47k 1/16W 5%
R0853	0662057A89	47k 1/16W 5%
R0855	0662057A89	47k 1/16W 5%
R0856	0662057A89	47k 1/16W 5%
R0857	0662057A89	47k 1/16W 5% Not used in Controlhead C
R0858	0662057A89	47k 1/16W 5% Not used in Controlhead B
R0859	0662057A89	47k 1/16W 5%
R0860	0662057A97	100k 1/16W
R0861	0662057A97	100k 1/16W
R0862	0662057A97	100k 1/16W
R0863	0662057A65	4k7 1/16W 5%
R0864	0662057A65	4k7 1/16W 5%
R0865	0662057A65	4k7 1/16W 5%
R0877	0660076A35	270 5 1/8
R0878	0660076A35	270 5 1/8
R0879	0660076A35	270 5 1/8
R0901	0662057A90	51k 1/16W 5%
R0902	0662057A76	13k 1/16W 5%
R0903	0662057A81	22k 1/16W 5%
R0904	0662057A88	43k 1/16W 5%
R0906	0662057A90	51k 1/16W 5%
R0907	0662057A76	13k 1/16W 5%
R0908	0662057A81	22k 1/16W 5%
R0909	0662057A88	43k 1/16W 5% Not used in Controlhead B
R0935	0662057A73	10k 1/16W 5%
R0936	0662057A73	10k 1/16W 5%
R0937	0660076A01	10 5 1/8
R0941	0662057A73	10k 1/16W 5%
R0942	0662057A85	33k 1/16W 5%
R0943	0662057A65	4k7 1/16W 5%
R0944	0662057A97	100k 1/16W
R0945	0662057A73	10k 1/16W 5%
R0946	0662057A73	10k 1/16W 5%
R0947	0660076A01	10 5 1/8
R0948	0660076A01	10 5 1/8

Circuit Ref	Motorola Part No	Description
R0972	0662057B47	0 1/16W
R0973	0662057B24	1.2M 1/16W 5%
R0974	0662057B28	1.8M 1/16W 5%
R0975	0662057G29	200k 0.1W 1%
R0976	0662057G13	100k 0.1W 1%
*U0831	5113802A24	IC 68HC11 W/SCI,SPI,A/D
U0832	5113815A02	MC33064 UNDER VLTG SENSING
U0833	4886061B01	CER RESONATOR 8MHZ CSTCC8.00MG
U0834	5185963A15	TEMP SENSOR 1M5
U0931	5113818A03	IC HIGH PERFORMANCE SI
U0971	5186158B01	LCD DRIVER SED1526F0A
VR0812	4813830A15	DIODE 5.6V 5% 225mW
VR0816	4805656W09	DIODE ZENER QUAD MMQA20VT1
VR0817	4805656W09	DIODE ZENER QUAD MMQA20VT1
VR0821	4813830A23	DIODE 10V 5% 20mA 350mW
VR0822	4813830A15	DIODE 5.6V 5% 225mW

* Motorola Depot Servicing only

Reference designators with an asterisk indicate components which are not fieldreplaceable because they need to be calibrated with specialized factory equipment after installation. Radios in which these parts have been replaced in the field will be off frequency at temperature extremes.

4.0 Controlhead GM380/1280 - PCB 8486178B03 / Schematics

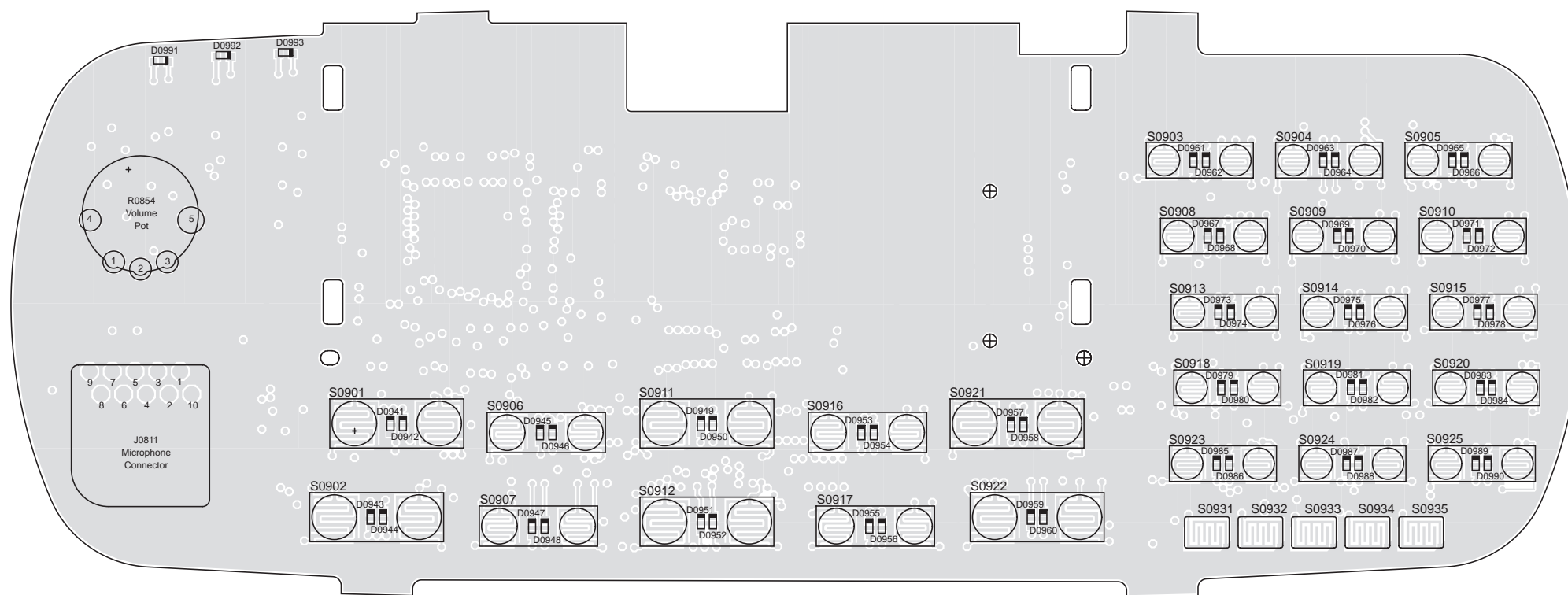

ZWG0130368-A Top Side

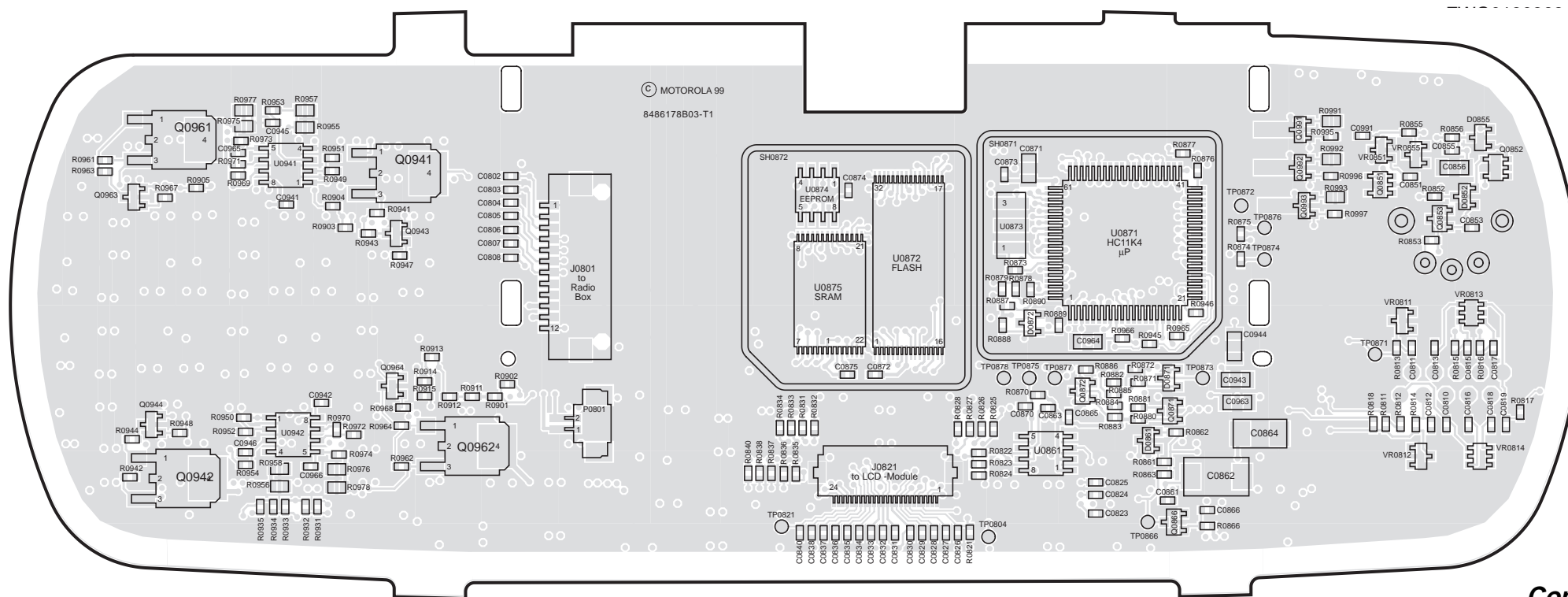

ZWG0130369-B Bottom Side

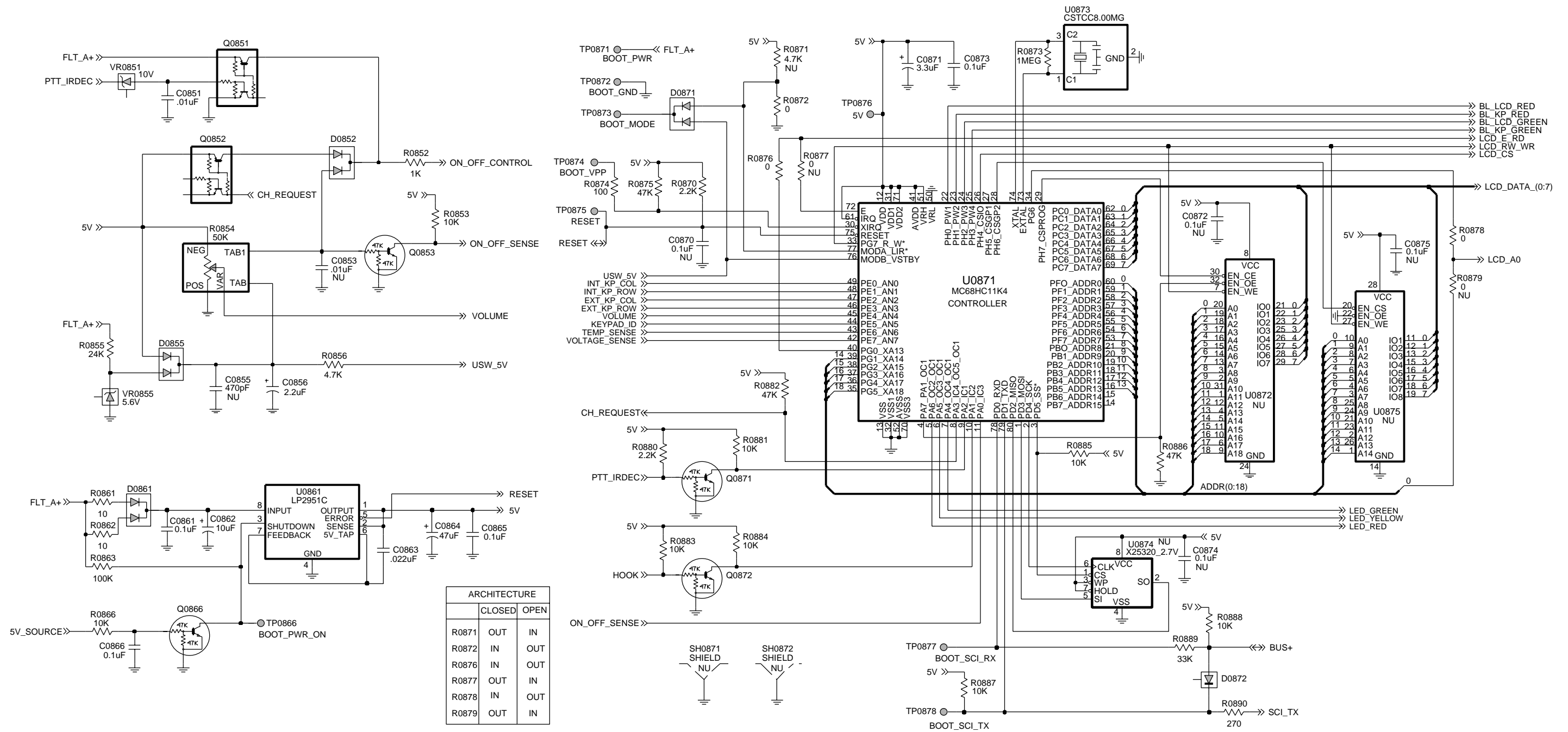

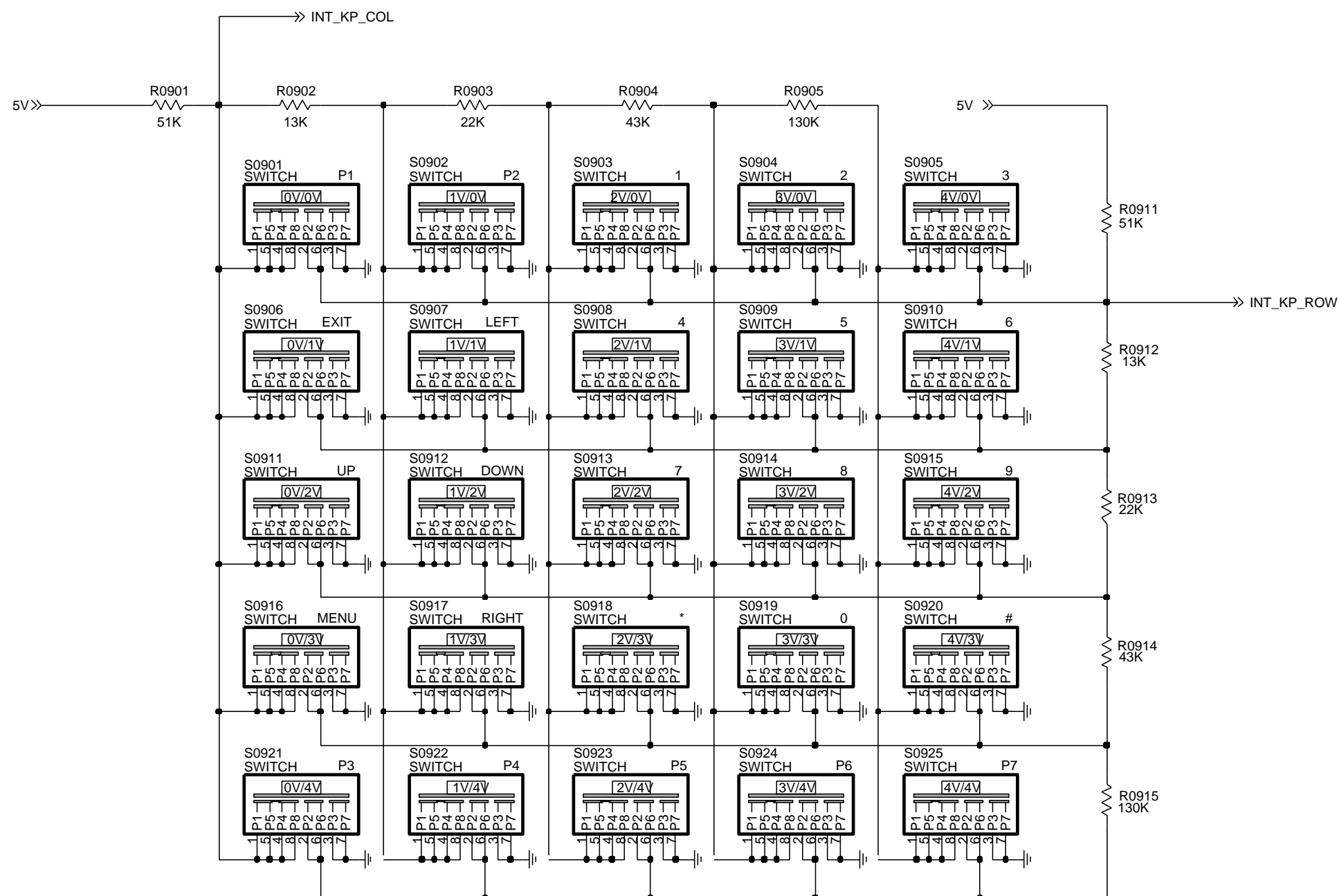
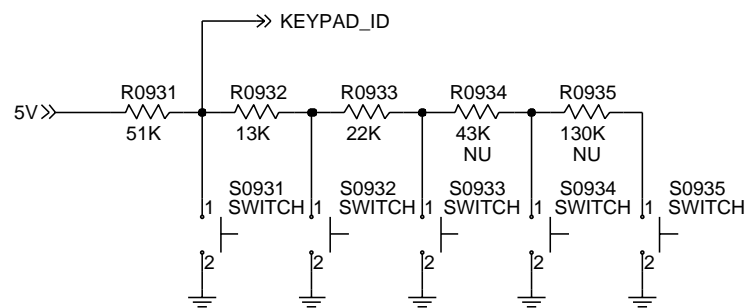
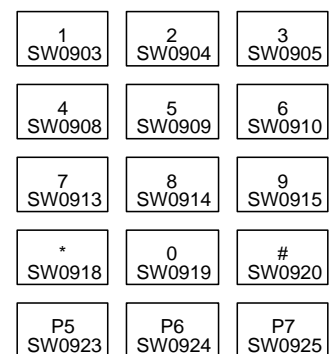
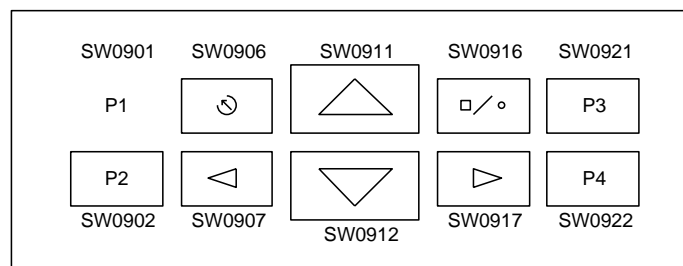

ZWG0130371-A

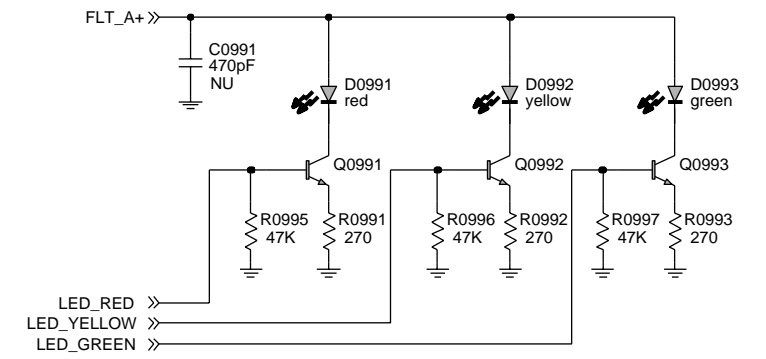
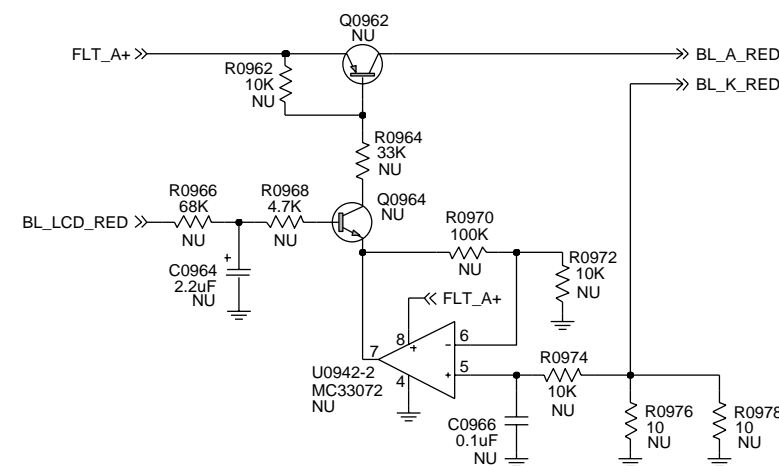
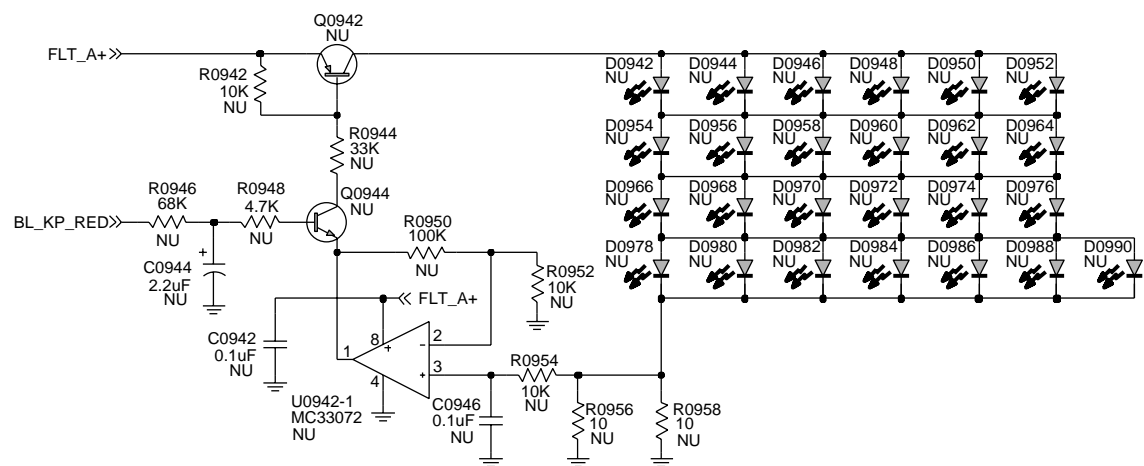
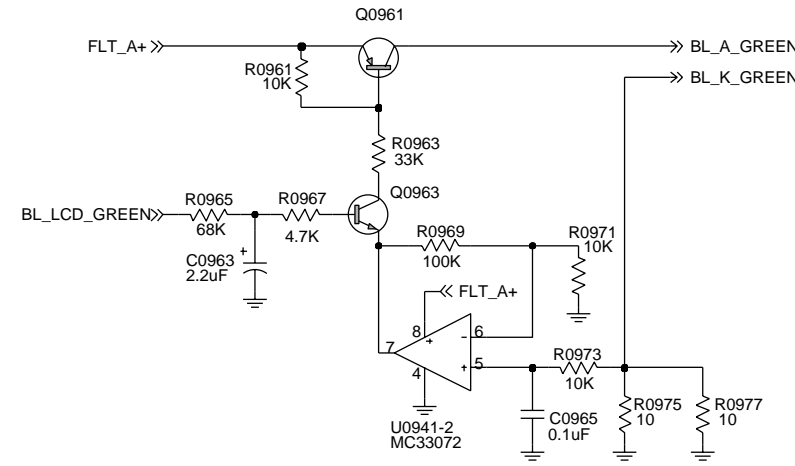
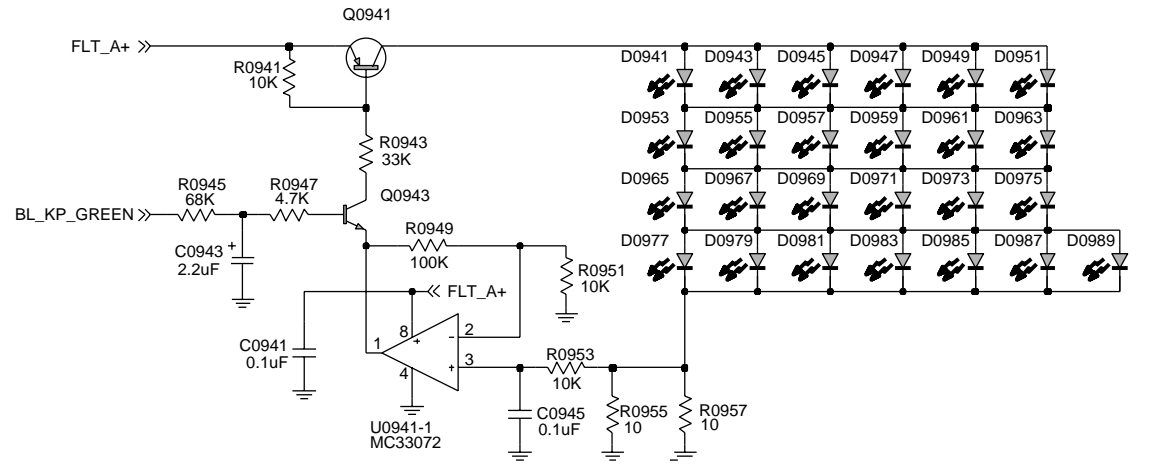

ZWG0130372-A

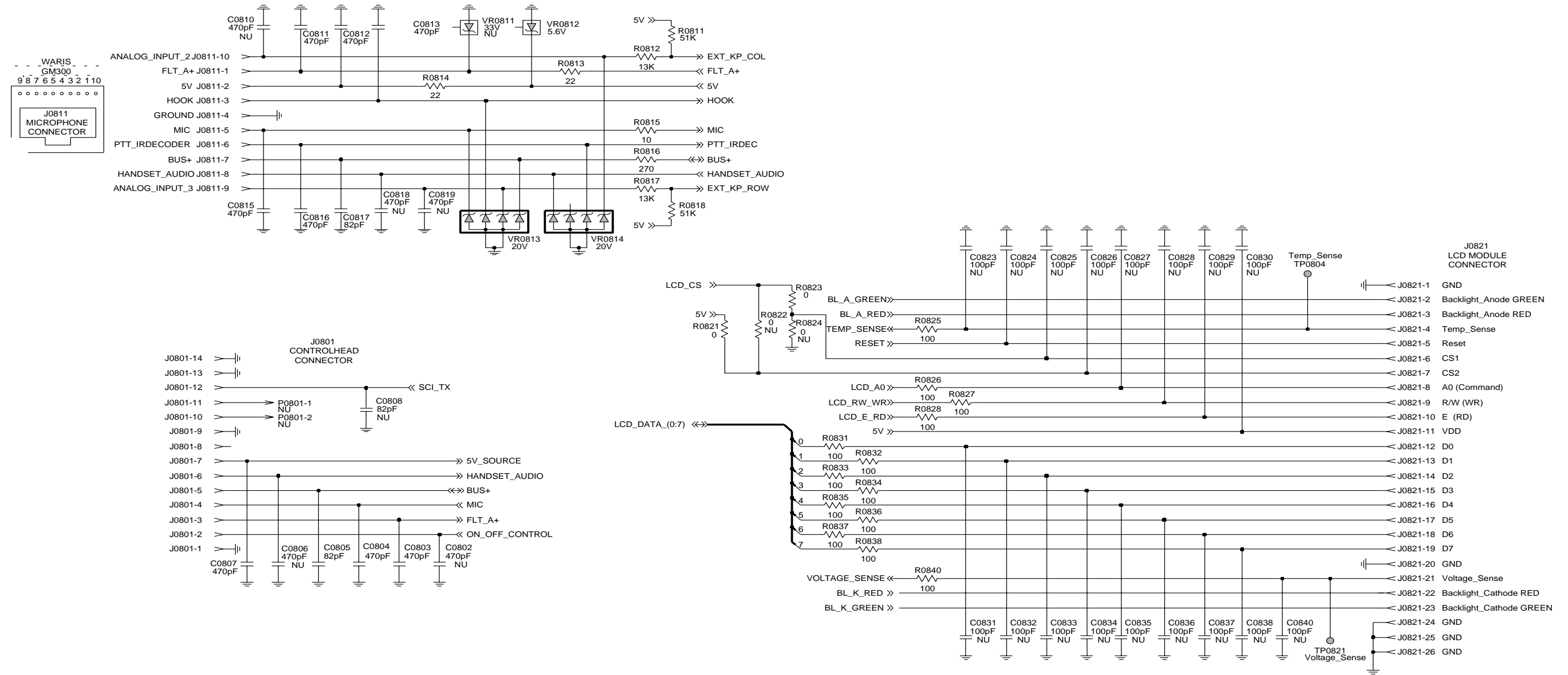

ZWG0130373-A

4.1 Controlhead PCB 8486178B03 Parts List

Circuit Ref	Motorola Part No	Description
C0803	2113741F17	470pF 50V
C0804	2113741F17	470pF 50V
C0805	2113740F49	82pF 5% 50V
C0807	2113741F17	470pF 50V
C0811	2113741F17	470pF 50V
C0812	2113741F17	470pF 50V
C0813	2113741F17	470pF 50V
C0815	2113741F17	470pF 50V
C0816	2113741F17	470pF 50V
C0817	2113740F49	82pF 5% 50V
C0851	2113741F49	10nF 50V
C0856	2311049A40	TANT CP 2.2uF 10% 10V
C0861	2113743E20	100nF 16V
C0862	2311049A45	TANT CP 10uF 10% 35V
C0863	2113743E07	22nF 16V
C0864	2311049A99	TANT CP 47uF 20% 10V
C0865	2113743E20	100nF 16V
C0866	2113743E20	100nF 16V
C0871	2311049A42	TANT CP 3.3uF 10% 6V
C0873	2113743E20	100nF 16V
C0941	2113743E20	100nF 16V
C0942	2113743E20	100nF 16V
C0943	2311049A40	TANT CP 2.2uF 10% 10V
C0944	2311049A40	TANT CP 2.2uF 10% 10V
C0945	2113743E20	100nF 16V
C0946	2113743E20	100nF 16V
C0963	2311049A40	TANT CP 2.2uF 10% 10V
C0964	2311049A40	TANT CP 2.2uF 10% 10V
C0965	2113743E20	100nF 16V
C0966	2113743E20	100nF 16V
D0852	4813833C02	DUAL SOT MMBD6100
D0855	4813833C02	DUAL SOT MMBD6100
D0861	4813833C02	DUAL SOT MMBD6100
D0871	4813833C02	DUAL SOT MMBD6100
D0872	4880236E05	DIODECHIP SCHOTTKY
D0941	4886171B04	LED GREEN
D0942	4886171B01	LED RED
D0943	4886171B04	LED GREEN
D0944	4886171B01	LED RED
D0945	4886171B04	LED GREEN
D0946	4886171B01	LED RED
D0947	4886171B04	LED GREEN
D0948	4886171B01	LED RED
D0949	4886171B04	LED GREEN
D0950	4886171B01	LED RED
D0951	4886171B04	LED GREEN
D0952	4886171B01	LED RED

Circuit Ref	Motorola Part No	Description
D0953	4886171B04	LED GREEN
D0954	4886171B01	LED RED
D0955	4886171B04	LED GREEN
D0956	4886171B01	LED RED
D0957	4886171B04	LED GREEN
D0958	4886171B01	LED RED
D0959	4886171B04	LED GREEN
D0960	4886171B01	LED RED
D0961	4886171B04	LED GREEN
D0962	4886171B01	LED RED
D0963	4886171B04	LED GREEN
D0964	4886171B01	LED RED
D0965	4886171B04	LED GREEN
D0966	4886171B01	LED RED
D0967	4886171B04	LED GREEN
D0968	4886171B01	LED RED
D0969	4886171B04	LED GREEN
D0970	4886171B01	LED RED
D0971	4886171B04	LED GREEN
D0972	4886171B01	LED RED
D0973	4886171B04	LED GREEN
D0974	4886171B01	LED RED
D0975	4886171B04	LED GREEN
D0976	4886171B01	LED RED
D0977	4886171B04	LED GREEN
D0978	4886171B01	LED RED
D0979	4886171B04	LED GREEN
D0980	4886171B01	LED RED
D0981	4886171B04	LED GREEN
D0982	4886171B01	LED RED
D0983	4886171B04	LED GREEN
D0984	4886171B01	LED RED
D0985	4886171B04	LED GREEN
D0986	4886171B01	LED RED
D0987	4886171B04	LED GREEN
D0988	4886171B01	LED RED
D0989	4886171B04	LED GREEN
D0990	4886171B01	LED RED
D0991	4886171B01	LED RED
D0992	4886171B03	LED YELLOW
D0993	4886171B04	LED GREEN
J0801	0902636Y02	CONN FLEX 12 PIN
J0811	2864287B01	CONN TELCO 10 PIN JACK
J0821	0986197B01	CONN ZIF HOR 24PIN
P0801	2809926G01	CONN1.25MM 2PIN SUR MT
Q0851	4805921T02	DUAL ROHM FMC2 RH
Q0852	4805921T02	DUAL ROHM FMC2 RH
Q0853	4880048M01	NPN DIG 47k/47k
Q0866	4880048M01	NPN DIG 47k/47k
Q0871	4880048M01	NPN DIG 47k/47k
Q0872	4880048M01	NPN DIG 47k/47k

Circuit Ref	Motorola Part No	Description
Q0941	4813822A08	PNP 25V 5A MJD210T4
Q0942	4813822A08	PNP 25V 5A MJD210T4
Q0943	4813824A10	NPN 40V .2A B=50-150
Q0944	4813824A10	NPN 40V .2A B=50-150
Q0961	4813822A08	PNP 25V 5A MJD210T4
Q0962	4813822A08	PNP 25V 5A MJD210T4
Q0963	4813824A10	NPN 40V .2A B=50-150
Q0964	4813824A10	NPN 40V .2A B=50-150
Q0991	4813824A10	NPN 40V .2A B=50-150
Q0992	4813824A10	NPN 40V .2A B=50-150
Q0993	4813824A10	NPN 40V .2A B=50-150
R0811	0662057A90	51k 1/16W 5%
R0812	0662057A76	13k 1/16W 5%
R0813	0662057A09	22 1/16W 5%
R0814	0662057A09	22 1/16W 5%
R0815	0662057A01	10 1/16W 5%
R0816	0662057A35	270 1/16W 5%
R0817	0662057A76	13k 1/16W 5%
R0818	0662057A90	51k 1/16W 5%
R0821	0662057B47	0 1/16W
R0823	0662057B47	0 1/16W
R0825	0662057A25	100 1/16W 5%
R0826	0662057A25	100 1/16W 5%
R0827	0662057A25	100 1/16W 5%
R0828	0662057A25	100 1/16W 5%
R0831	0662057A25	100 1/16W 5%
R0832	0662057A25	100 1/16W 5%
R0833	0662057A25	100 1/16W 5%
R0834	0662057A25	100 1/16W 5%
R0835	0662057A25	100 1/16W 5%
R0836	0662057A25	100 1/16W 5%
R0837	0662057A25	100 1/16W 5%
R0838	0662057A25	100 1/16W 5%
R0840	0662057A25	100 1/16W 5%
R0852	0662057A49	1k 1/16W 5%
R0853	0662057A73	10k 1/16W 5%
R0854	1805911V02	POT VOL
R0855	0662057A82	24K 1/16W 5%
R0856	0662057A65	4k7 1/16W 5%
R0861	0662057A01	10 1/16W 5%
R0862	0662057A01	10 1/16W 5%
R0863	0662057A97	100k 1/16W
R0866	0662057A73	10k 1/16W 5%
R0870	0662057A57	2k2 1/16W 5%
R0872	0662057B47	0 1/16W
R0873	0662057B22	1M 1/16W 5%
R0874	0662057A25	100 1/16W 5%
R0875	0662057A89	47k 1/16W 5%
R0876	0662057B47	0 1/16W
R0878	0662057B47	0 1/16W
R0880	0662057A57	2k2 1/16W 5%

Circuit Ref	Motorola Part No	Description
R0881	0662057A73	10k 1/16W 5%
R0882	0662057A89	47k 1/16W 5%
R0883	0662057A73	10k 1/16W 5%
R0884	0662057A73	10k 1/16W 5%
R0885	0662057A73	10k 1/16W 5%
R0886	0662057A89	47k 1/16W 5%
R0887	0662057A73	10k 1/16W 5%
R0888	0662057A73	10k 1/16W 5%
R0889	0662057A85	33k 1/16W 5%
R0890	0662057A35	270 1/16W 5%
R0901	0662057A90	51k 1/16W 5%
R0902	0662057A76	13k 1/16W 5%
R0903	0662057A81	22k 1/16W 5%
R0904	0662057A88	43k 1/16W 5%
R0905	0662057B01	130K 1/16W 5%
R0911	0662057A90	51k 1/16W 5%
R0912	0662057A76	13k 1/16W 5%
R0913	0662057A81	22k 1/16W 5%
R0914	0662057A88	43k 1/16W 5%
R0915	0662057B01	130K 1/16W 5%
R0931	0662057A90	51k 1/16W 5%
R0932	0662057A76	13k 1/16W 5%
R0933	0662057A81	22k 1/16W 5%
R0941	0662057A73	10k 1/16W 5%
R0942	0662057A73	10k 1/16W 5%
R0943	0662057A85	33k 1/16W 5%
R0944	0662057A85	33k 1/16W 5%
R0945	0662057A93	68k 1/16W 5%
R0946	0662057A93	68k 1/16W 5%
R0947	0662057A65	4k7 1/16W 5%
R0948	0662057A65	4k7 1/16W 5%
R0949	0662057A97	100k 1/16W
R0950	0662057A97	100k 1/16W
R0951	0662057A73	10k 1/16W 5%
R0952	0662057A73	10k 1/16W 5%
R0953	0662057A73	10k 1/16W 5%
R0954	0662057A73	10k 1/16W 5%
R0955	0660076A01	10 5 1/8
R0956	0660076A01	10 5 1/8
R0957	0660076A01	10 5 1/8
R0958	0660076A01	10 5 1/8
R0961	0662057A73	10k 1/16W 5%
R0962	0662057A73	10k 1/16W 5%
R0963	0662057A85	33k 1/16W 5%
R0964	0662057A85	33k 1/16W 5%
R0965	0662057A93	68k 1/16W 5%
R0966	0662057A93	68k 1/16W 5%
R0967	0662057A65	4k7 1/16W 5%
R0968	0662057A65	4k7 1/16W 5%
R0969	0662057A97	100k 1/16W
R0970	0662057A97	100k 1/16W

Circuit Ref	Motorola Part No	Description
R0971	0662057A73	10k 1/16W 5%
R0972	0662057A73	10k 1/16W 5%
R0973	0662057A73	10k 1/16W 5%
R0974	0662057A73	10k 1/16W 5%
R0975	0660076A01	10 5 1/8
R0976	0660076A01	10 5 1/8
R0977	0660076A01	10 5 1/8
R0978	0660076A01	10 5 1/8
R0991	0660076A35	270 5 1/8
R0992	0660076A35	270 5 1/8
R0993	0660076A35	270 5 1/8
R0995	0662057A89	47k 1/16W 5%
R0996	0662057A89	47k 1/16W 5%
R0997	0662057A89	47k 1/16W 5%
U0861	5105469E65	IC VLTG REGLTR LP2951C
*U0871	5113802A32	68HC11 W/SCI SPI A/D
U0873	4886061B01	CER RESONATOR 8MHZ
U0941	5113818A03	IC HIGH PERFORMANCE SI
U0942	5113818A03	IC HIGH PERFORMANCE SI
VR0812	4813830A15	DIODE 5.6V 5% 225mW
VR0813	4805656W09	ZENER QUAD MMQA20VT1
VR0814	4805656W09	ZENER QUAD MMQA20VT1
VR0851	4813830A23	DIODE 10V 5% 20mA 350mW
VR0855	4813830A15	DIODE 5.6V 5% 225mW

* Motorola Depot Servicing only

Reference designators with an asterisk indicate components which are not fieldreplaceable because they need to be calibrated with specialized factory equipment after installation. Radios in which these parts have been replaced in the field will be off frequency at temperature extremes.

